

Maintenance Manual

Volumed[®] μ VP7000

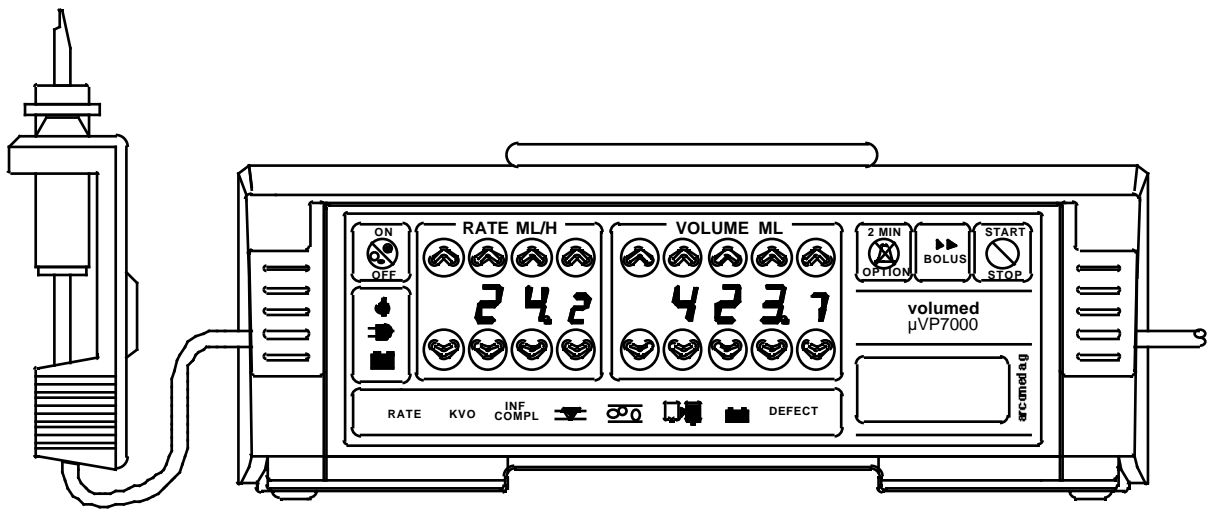

Swiss Made



ARCOMED AG
8105 Regensdorf / Zürich
(an ISO 9001 company)

Important

This manual is exclusively intended for authorized personnel who have been instructed by Arcomed AG in the maintenance and repair of the Infusion Pump indicated above.

Arcomed AG shall assume no liability for tampering by unauthorized persons.

Caution: The manufacturer reserves the right to improve the specifications of this product without prior notice.

Edition 02/03 -VA-TM-7000-E

Contents

	Page
Index numbers	0
1. Introduction	1
1.2.2 Service Intervals	2
2. Specifications	3
3. Operation	4
3.18 Parallel / Multiple Infusions	10
4. Alarm Supervision System	11
5. Warranty	13
Design Changes	13
6. Inspection and Maintenance Intervals	14
7. Significance of Trumpet Curves	15
8. Technical description	17
9. Trouble shooting	21
10. Replacement of parts	22
11. Spare parts list 7000	23
Annex A	Drawings
Annex B	Schematics
Annex C	Component layout

Index Numbers

1	Administration set
2	Drip chamber
3	Stop flow clamp (internal or robson clamp)
4	Empty container detector (ECD)
5	Door
6	Door latch
7	On / OFF key
8	Rate display
9	Volume display
10	Start / Stop key
11	Tube guides
12	Pumping-peristaltic
13	Occlusion detector
14	Stop flow device
15	Air detector
16	Rate keys
17	Volume keys
18	Option key, Alarm tone-mute key
19	Prime / Bolus key
20	Alphanumeric LCD display
21	Alarm window
22	Information window
23	Mains supply socket
24	Fuses
25	Connector nurse call
26	Connector empty container detector (ECD)
27	External power supply (12 DC)
28	Infra red interface
29	Pole clamp
30	Carrying handle

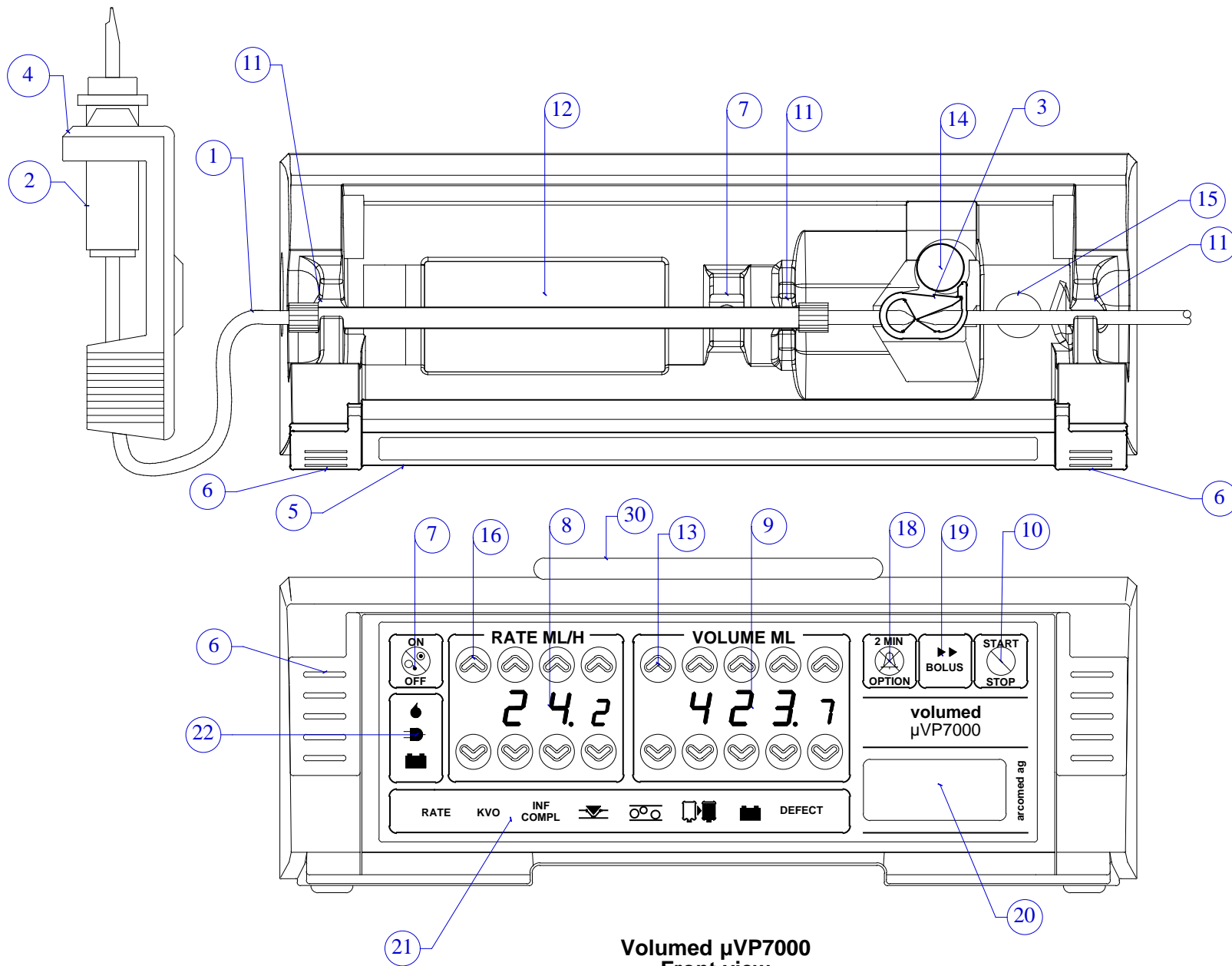

**Volved μVP7000
Front view**

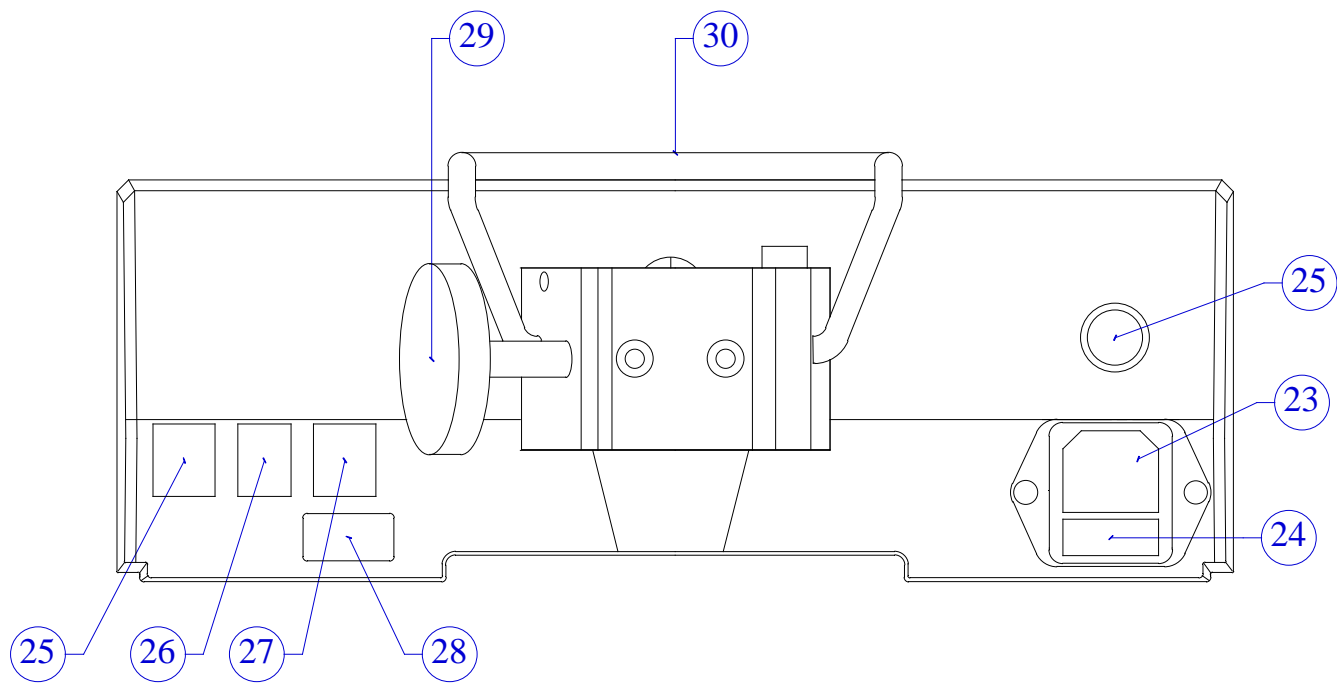

Volumed μ VP7000
Rear view

1. Introduction

1.0 Introduction

The Volumed® μ VP7000 Volumetric Infusion Pump has been developed using the latest state-of-the-art technology. This microprocessor-controlled volumetric pump operates by pumping the infusate using a peristaltic system. The sterility of the infusate is not affected. The pump is designed to infuse drugs or other infusates into the patient by controlled means under pressure.

The Volumed μ VP7000 meets the performance requirements of the MDA (UK) for neonatal and high risk infusions. It can be used in both stationary and transportable applications as it has a battery life up to 6 hours duration. Applications include neonatology, intensive and cardiac care, paediatrics, gynaecology and obstetrics, surgery and general medicine. It can also be used in ambulances or for laboratory use. For infusions with very small rates and small volumes it is recommended to use a syringe pump such as the Syramed® μ SP6000 as the the remaining volume in the administration set can become significant compared to the infused volume.

The Volumed μ VP7000 meets the Medical Device Directive (MDD) requirements of the EC Guideline 93/42 EEC and is marked CE.

Classification: Class IIb

The manufacturer according to MDD is Arcomed AG, Althardstrasse 146, CH 8105 Regensdorf, Zurich, Switzerland. Responsible for the EC is Arcomedical Infusion Ltd., West Horndon, Essex CM13 3XS, UK.

The Volumed μ VP7000 may be operated only on mains power installed to DIN 57107 VDE 0107 or the appropriate national standards. If the integrity of the mains power supply protective earth system is in doubt, the pump should be operated on battery power. Mobile telephones should not be used anywhere near this equipment.

1.1 Mounting the pump

Check the pump and accompanying accessories for damage when unpacking. The pump must not be operated if damaged. Should the pump be damaged contact our Service Department.

Permitted mounting: positioned on a flat horizontal surface or pole mounted on an infusion stand or rail mounted.

The pump should normally be operated from a mains power supply. The internal batteries will automatically operate the pump in the event of a power failure.

CAUTION: This pump is not designed for use in areas where there is an explosion hazard. Environmental requirements as per IEC601-1-2 must be observed. Do not operate this pump in an environment with high levels of electromagnetic radiation such as surgical diathermy or mobile telephones. For further information contact the official distributor in your country or the Customer Service Department in Switzerland:

Switzerland: a r c o m e d a g, Althardstr. 146, CH-8105 Regensdorf
Tel. 0041 (01)840'47'40, Fax. 0041 (01)840'06'49

United Kingdom: Arcomedical Infusion Ltd., 5g West Horndon Industrial Estate, West Horndon, Essex CM13 3X

The technical manual and the list of spares and used materials can be requested from Arcomed.

1.2.1 Cleaning and disinfection

CAUTION: The pump must be switched off and disconnected from the mains power supply before cleaning and disinfecting.

The pump must be kept clean and dry. Remove any spillage immediately. The pump must not be placed in an autoclave.

The unit is disinfected by wiping over with a cloth which has been damped slightly with an alcohol-based disinfectant. Take care when cleaning that no liquid enters the inside of the pump case. Wait at least 30 seconds after disinfecting before switching the pump on. Use only disinfectant that are compliant with:

- ABS, POM, stainless steel, PVC, aluminum, silicone

Please check with your supplier of disinfectant.

1.2.2 Annual safety check

Battery power is provided by a nickel metal hydride (NiMH) battery which must be checked annually. Battery condition is checked by connecting the pump to the mains power supply for 15 hours in a switched off condition so that the battery may be fully charged. Disconnect the mains power supply and switch the pump on using battery power. Determine the operating time when the low battery alarm activates. This should be at least 3 hours - if not the battery must be replaced. Repeated charging and discharging may in certain circumstances cause degeneration of the battery (memory effect).

Used batteries must be disposed of in an environmentally friendly manner or returned to the manufacturer.

Safety checks (see chapter 6) may be performed only by qualified staff.

1.3. Key to symbols

The pictograms and symbols shown on the reverse of the pump have the following meanings or functions:



Nurse Call



CF (cardiac floating) part



Empty bag detector



CAUTION: consult accompanying documents

12 VDC

External 12 VDC supply

IPX 1

Drip-proof

IR

Interface RS232
(Infrared Interface)



class II double insulated

2. Specifications

CE Mark	A23 02 04 07000 01
Classification	IIb
Software revision	1.xx
Flow rate range (ml/h)	0.1 - 999.0 ml/h, increments: 0.1 ml/h
Volume range (ml)	0.1 - 9999.9 ml, increments: 0.1 ml
Deviation in flow-rate with 8101P series administration set	typ. +/- 3% (Silicone insert)
Deviation in flow-rate with 3101P series administration set	typ. +/- 5% (PVC line)
Overinfusion in case of electrical or mechanical defect	1.5 ml max.
Keep vein open rate (KVO)	3.0 ml/h, adjustable
Bolus rate, Prime rate	1000 ml/h, adjustable
Infusion pressure min.	60 kPa / 450 mmHg / 0.6 bar
Infusion pressure max.	120-250 kPa / 900-1875 mmHg 1.5-2.5 bar (according to IV set)
Alarm pressure limit	0 - 999 mbar/mmHg
Bolus volume after occlusion	Automatic bolus reduction (see also 3.9)
Time to alarm after occlusion	Depending on rate, pressure limit setting and set, see also table below.
Air detection	ultrasonic
Sensitivity	typ. 100 µl, adjustable from 50 to 250 µl Cumulated 15 min adjustable from 500 to 5000 µl
Battery operation time (1.85Ah)	3 - 5 hrs (dependent on rate and mode)
Charging time	15 hours/20 hours
Supply voltage	230 VAC+10%-15%, 50/60 Hz
External power supply (optional)	12 VDC
Input power	9.3 VA
Mains fuse	T200 mA/IEC127/III/SEV 1064
Type of protection against electric shock	Class II
Protection against ingress of liquids	IPX 1, drip proof
Leakage current	< 40µA
Radio interference	CE-Class A
Nurse call, potential-free contact switch	24V/0.2A
Degree of protection against electric shock	CF (cardiac floating)
Dimensions	245x90x180 mm (WxHxD)
Housing	ABS plastic, UL listed
Weight	2.6 kg (approx.)

Max. storage period 3 months without charging
 Permitted temperature range (operation/storage) 15°C - 35°C / 0°C- 40°C
 Permitted relative humidity 20-90% max. (no vapor deposit)

Atmospheric pressure 500-1000 hPa
 Safety certification DIN IEC 601 Part 1
 EN55011 Radio interference
 IEC60601-1-2 Susceptibility
 IEC60601-2-24

Operating modes Continual, manual bolus, automatic bolus, priming.

Labeling of the pump 12 alpha numeric characters.
 Configured through IR interface.

History Up to 1500 data logs with real time stamps.
 Read out and printout through IR interface and PC.

Time to alarm after occlusion (PVC set), volume of bolus **without** bolus reduction:

Pressure Rate	1.0 bar	500 mbar	100 mbar
1 ml/h	>60 min	45 min	8 min
20 ml/h	3.5 min	100 sec	20 sec
100 ml/h	50 sec	25 sec	5 sec
999 ml/h	6 sec	2.5 sec	0.5 sec
Bolus	0.9 ml	0.45 ml	0.09 ml

3. Operation

The figures in brackets refer to the illustrations of front and rear views shown in the appendices.

CAUTION: Use only approved disposable administration sets!
(cf. leaflet "Accessories and Consumables")

The performance of the pump depends on both pump and administration set. The volumed must only be used with the sets the pump has been calibrated to. The functional safety of the pump cannot be guaranteed if non-approved IV sets are used. The safety of the patient may be compromised as a result.

Disposable IV sets are for single-use only. Single-use needles carry an infection hazard and must be disposed of in accordance with local guidelines. The IV-set should be replaced every 24 hours.

3.1. Preparation and loading of the administration set

- a) If the pump is to be operated on an infusion stand, care must be taken that the pump is not positioned more than 1.4m above the ground to ensure stability. Ideally use an "Arco Luxe" or "Arco Standard" infusion stand. If several pumps are mounted one above the other the maximum permitted height from the floor must be observed and measures taken to **prevent instability**. The pump may be fixed to the infusion stand by means of the pole clamp (29) on the rear of the unit.
- b) Slot the **drip chamber** (2) into the empty container detector (4). Make sure that there are no large ribs or joints in the passage of the empty container detector and that fallen drops are detected by the drop-detector's light-barrier.
- c) Carefully purge the **infusion set** (1), without allowing any air bubbles to enter, until the drip chamber (2) is 1/4 to 1/3 full. If air has entered, repeat purge-procedure.
- d) Close the tubing **roller clamp**.
- e) Open the **pump door** (5) by pulling the **latch** (6).
- f) Pump with Robson Clamp:
Position the **Robson clamp** (3) on the tubing. In case of a silicon insert tubing, position the Robson clamp just left of the silicone segment. Close the Robson clamp. Hold the tubing with your right hand with your thumb positioned on the Robson clamp. Starting with the left side, insert the IV set into the left **tube guide** (11). Ensure that the flow direction of the pump from the left to the right is respected and the tubing is in a straight line. Put the Robson clamp with your thumb into the **Stop Flow device** (14) and insert the remaining tubing onto the right tube guide (11).
Pump with internal clamp:
Starting with the left side, insert the IV set into the left and right **tube guides** (11). Ensure that the flow direction of the pump from the left to the right is respected and the tubing is in a straight line. In case of a silicon insert tubing verify the correct position of the silicon insert as shown in the front view of this manual.
- g) Close the door (5) and push the **latch** (6) firmly against the pump. Open the tubing **roller clamp**.

- h) **Switch the pump on:** Press ON/OFF key (\odot/\circ) (10). The audible alarm beeps once together with the indication < ! > in the alarm window (21). The software version number (μ VP7000, rx.xx) and the configuration of the pump (μ VP7000, c.xxx) light up briefly.

Wait until the automatic **Stop Flow test** is terminated.

- i) Check if there is no free flow. Where possible mains power should be used. Plug the mains power cable into the connector socket (18) at the rear of the pump. The mains pictogram illuminates as soon as the mains supply is connected. The battery is charged automatically.
- j) The Volumed μ VP7000 has the possibility to **prime** the line with the pump. Make sure the patient is always disconnected when priming:
Press the bolus key (19) until the LCD display (20) shows: *priming?* Press and hold the bolus key until the priming is finished. To terminate the priming mode press the Start/Stop key (10). Important: during priming both air alarm and empty bag alarm are ignored. The prime rate is displayed in the rate window (8).

- k) **Connect set to the patient.**

Important: Before the door is opened, close the roller clamp!

3.2. Setting rate (ml/h) and volume (ml)

Use the UP/DOWN keys (16) to select the required rate in ml/h indicated in the RATE display (8). Arrow up keys provide rate increase, arrow down keys provide rate decrease. Check that each key stroke changes one digit. The least significant digit (small size) indicates 0.1 (units).

If a specific volume (VTBI) is to be infused, the required volume in mls may be selected in the VOLUME window (10) using the UP/DOWN keys (13) before starting the pump (optional). Once the VTBI is reached, the pump gives an audible alarm and displays <INF COMPL> (infusion complete) in the Alarm window (21). The pump switches to the KVO rate.

Remark: With the empty bag detector (4) the pump stops automatically after the last drop in the bag. If no empty bag detector is used, the volume (VTBI) has to be set to stop before the bag is completely emptied. Otherwise the pump continues infusing until air is detected in the air detector (18). Hence, it is strongly recommended to use the empty bag detector.

3.3. Pump running

When the pump is running, the green drop symbol flashes (22). The VOLUME display now indicates the volume infused in mls. In order to display various data, such as pump condition, volume to be infused, infusion time, time to end of infusion, battery condition, pressure and pressure limit, press the OPTION key (18) sequentially and observe the LCD window (20) until the required data is displayed.

If a specific volume to be infused was selected the pump automatically switches to KVO operation when this volume has been infused and an audible and visual alarm (21) activates.

Press the ALARM SILENCE key (5) to silence the audible alarm for 2 minutes.

3.4. Resetting the volume infused

In order to reset the volume infused, stop the pump by pressing the STOP key (10). Press the OPTION key (18) for 2 seconds until the VOLUME display (9) flashes. When the LCD window (20) displays "000", confirm this by pressing the START/STOP key (10) to reset the volume infused to zero. If it is not desired to reset the volume infused, press the OPTION key (18) until the normal display appears.

3.5. Infusing a bolus

When the pump is infusing, a manual or an automatic bolus can be given.

To infuse a manual bolus:

Press the OPTION key (18) and the BOLUS key (19) together.

The bolus rate is displayed in the RATE window (8) and the bolus volume infused is displayed in the VOLUME window (9). The LCD window (20) indicates "Bolus manual". Keep the keys depressed until the required bolus volume has been infused. As soon as the keys are released the pump reverts to the normal infusion mode.

To infuse an automatic bolus:

Press the Bolus key (19) for 2 seconds until the display in the VOLUME window (9) flashes. The desired bolus volume in mls can then be preset in the VOLUME display using the VOLUME keys (13). Press the BOLUS key (19) to deliver the bolus automatically. If no bolus is required, press the OPTION key (18) to cancel.

During automatic bolus delivery, the RATE display (8) indicates the bolus rate and the VOLUME display (9) indicates the bolus volume infused. The LCD window (20) indicates "Bolus automatic".

To stop the pump at any time press the STOP key (10).

After the selected bolus volume has been delivered, the pump switches automatically to normal delivery mode.

Following bolus infusion, the bolus volume is added to the total ml infused.

3.6. IV container exchange

When changing the plastic container or bottle, infusion can be interrupted at any time by means of the 'Start/Stop' key (18) without affecting the set or displayed values. In this state, handling operations such as changing the container or IV set and rate changes can be implemented without activating the alarm. In the stop mode, 'KVO' operation is automatically activated.

If the pump remains in the stop mode for more than 4 minutes, the audible reminder alarm will sound.

3.7. Recall of previous data

If the pump has been accidentally switched off, data such as rate, volume to be infused and volume infused may be recalled during start up. Press the START/STOP key (10) and the ON/OFF key (7) together to recall all data.

3.8. Setting volume and time

If a specific volume is to be infused in a given time the RATE display must be left at zero. After inserting the IV set, closing the door and finishing the automatic test press and hold the OPTION key (18) until the RATE and VOLUME displays flash.

The time in hours and minutes may be selected in the RATE display (9) and the volume selected in the VOLUME display (9). The pump automatically calculates the infusion rate. Check this carefully in the LCD window (20) before starting the infusion.

3.9. Pressure system

The Volumed μ VP7000 has automatic pressure monitoring whereby the pressure in the system is measured via the pressure transducer. The alarm pressure limit can be set automatically or manually.

Automatic setting:

If the pump is configured for this mode, the alarm pressure limit is automatically matched to the set rate, the lower the rate, the lower the alarm pressure limit. The time to alarm can be viewed in the table of section 2.

Manual setting:

Press the OPTION key (18) sequentially to display pressure and alarm pressure limit in the LCD window (20). Hold down the OPTION key (18) until the VOLUME display (9) flashes "Lxxx". The pressure limit may be manually set using the VOLUME keys (17) in the VOLUME display (9) and the data in the LCD window changes accordingly. This can also be done while the infusion is in progress. NOTE: Manual setting of pressure deactivates the automatic pressure setting, i.e. the pressure remains at the current level independent of the rate selected.

If the pressure rises beyond the limit set, the pump stops and the stored bolus is automatically reduced to virtually zero volume. An audible and visual alarm is activated. Check the IV carefully for the cause of the alarm. Do not restart the pump until the occlusion is released.

3.10. Setting time and date

Press the OPTION key (18) sequentially to display date and time in the LCD window (20). Hold the OPTION key (18) down until the display flashes. The time may be set using the volume keys (17) in the Volume display (9), e.g. h9.45 = 9:45 am. This can also be done while the infusion is in progress.

The Volumed has the possibility to automatically adjust the daylight save time (summer time). The adjustments can be done as per EU, US or Australian regulations. If the text 'Clock !' should appear, replace the Lithium backup battery on the main PCB.

To set the date, first switch the pump off. Press the VOLUME 0.1 ml DOWN and VOLUME 100 ml DOWN keys (17) together whilst switching the pump on. This enables the Service Mode. Select the RATE display (8) according to the following table using the RATE keys (16). Then select the corresponding data in the VOLUME display (9) using the VOLUME keys (17). Press the START key (10) each time to confirm each setting:

<u>Rate display (9)</u>	<u>Volume display (10)</u>	<u>Function</u>
145	0 - 99	Year
144	1 - 12	Month
143	1 - 31	Date
142	1 - 7	Weekday (Monday = 1, Sunday = 7)

Press the ON/OFF key (7) to switch the pump off.

Note: Incorrect setting of date or time does not affect the correct functioning of the pump.

3.11. Different configurations

If a different configuration is required, please contact our Customer Service Department or the official ARCOMED distributor in your country.

3.12. Accessories and consumables

Accessories, expendable parts and single-use items may only be used if they comply with the appropriate international standard and national approvals. Sets, filters and extension sets must be CE marked. The ordering numbers can be found on the leaflet "Accessories and Consumables"

The Instructions for Use, the mains power supply cable and the empty bag detector (optional) are included as standard equipment with the Volumed μ VP7000. For accessories see also 3.19.

3.13. START/STOP key (10)

The START/STOP key (10) is used to start the pump after the rate has been selected. The pump may be stopped at any time using this key. An additional function of this key is to confirm various parameters.

3.14. Prime / Bolus key (19)

The PRIME/BOLUS key (19) key is used to prime the extension set. It is also used to initiate a manual or automatic bolus (3.5).

3.15. AUDIBLE ALARM SILENCE/ OPTION key (18)

The audible alarm may be silenced for 2 minutes using the ALARM SILENCE/OPTION key (18). The audible alarm is re-activated after this period.

If there is no audible alarm, the key serves as an OPTION key which enables selection of any option.

3.16. ON/OFF \odot/\circ . key (7)

The pump may be switched off using the ON/OFF key (7) if the infusion has been completed. All data displayed (rate and volume) is lost when the pump is switched off. In order to avoid switching the pump off accidentally, the ON/OFF key (7) must be pressed for at least one second before the pump switches off.

If the pump is connected to the mains, the STANDBY mode will switch in when the pump is switched off. This means that the battery will be charged and the charge condition indicated in the LCD window.

3.17. Keep-Vein-Open (KVO) - Rate

The pump may be configured to infuse at the keep vein open rate when the volume to be infused has been delivered. The KVO rate is preset at 3.0 ml/h and may be set (by a technician) to suite individual requirements if necessary. If the set rate is smaller than than the KVO rate, this rate becomes the KVO rate.

Remark: The latest standard uses the new wording Keep-Open-Rate (KOR). The meaning is identical to the KVO-rate.

3.18. Using the pump in parallel or multiple infusions

If additional infusion systems are connected to the patient's vascular system, this may lead to complications e.g. infusion of air, reverse-flow, interruptions due to alarms and inaccurate flow.

To prevent such incidents, please observe the recommendations as stipulated in DIN VDE 0753, Part 5 or contact your distributor.

3.19. Options for external connection to the pump

External equipment may only be connected to the Nurse call connector (25), empty bag detector (26) and external supply (27) if the system which results from this meets the requirements of standard EN60601-1-1 and if their safety has been certified by an approved international body.

- Use cable number 94070 to connect the Nurse call system. Important: The alarms on the pump have to be observed also when the nurse call is connected.
- If an external 12 VDC power supply is used and is linked to other equipment, ensure that the safety of the system complies with IEC60601-1. Use cable number 71630.
- Use only the external empty container detector Nr. 98502 (4)

Please contact the Customer Service Department of ARCOMED AG for details of the RS232 interface (IR interface) and how to link it to external systems.

4. Alarm system

4.1. Alarm causes

The electronic self-monitoring system continuously monitors the correct functioning of the pump and its displays whilst in operation. If a fault should occur, the infusion is stopped immediately and the alarm activates. The corresponding alarm symbol is illuminated continuously with a red colour and there is a continuous audible alarm. The nurse call alarm is activated at the same time.

The pump will not start:

- if no rate has been set (0 ml/h).
- if air is in the line
- if the door is open.
- if the IV set or the Robson clamp is not correctly installed.

During operation an audible alarm activates and the pump switches to the KVO rate if:

- the START/STOP key is operated.
- the VTBI is reached
- attempts are made to alter the rate during operation.

During operation an audible alarm activates and the pump stops if:

- the roller clamp is not opened.
- the bag is empty.
- battery capacity is low and the charge can no longer ensure controlled infusion.
- the infusion pressure exceeds the limit set.
- the door is opened.
- there is an internal defect.

With empty bag detector:

- if the detected drops do not correspond with the set tolerances.
- if the level in the drip chamber is too high.

4.2. Canceling the alarm condition

After rectifying the cause of the alarm or acknowledging the rate change, the alarm condition is canceled and infusion resumed by pressing the START/STOP - key (10).

4.3. Pressure limit/occlusion alarm

If the pressure in the system reaches the set pressure limit due either to a total or partial occlusion, the alarm activates and the occlusion alarm symbol and rate display flash. The LCD window displays "occlusion! check line!" The vein site should be checked to ensure there is no complication.

If the cause of the occlusion is removed, the occlusion symbol flashes and the pump may be started again.

4.3. Battery alarm

The pump may be operated independently of the mains power supply using the internal battery. If the mains power supply fails, the pump switches automatically to battery operation to continue the infusion without interruption.

Battery operation is indicated by illumination of the battery symbol (22). Battery capacity permits from 3 up to 6 hours operation (1.85 Ah battery) depending on the infusion rate set. After approximately 3 to 6 hours operation the battery symbol in the alarm display (21) illuminates and an audible alarm activates. Alarms are canceled automatically as soon as mains power is restored.

A low battery alert is activated approximately 30 minutes before the battery depleted alarm. The battery symbol (21) flashes and an audible alarm activates. To silence the audible alarm, press the ALARM SILENCE key (18). The battery symbol continues to flash until the pump is reconnected to the mains.

A cautionary alarm is activated if the pump is disconnected from the mains power supply whilst in operation. This alarm may be silenced using the ALARM SILENCE key (5).

4.4. Nurse call

The pump may be connected to the external nurse call system via the connector (25) on the rear of the unit using cable part number 94070. All alarms are transmitted to the nurse call station. The normal pump alarms and displays continue to function.

4.5. Alarm silence

Audible alarms may be silenced for approximately 2 minutes using the ALARM/SILENCE key (18). The audible alarm is reactivated after this period.

4.6. Alarm indicators (18)

The cause of the alarms are indicated using illuminated pictograms as shown:

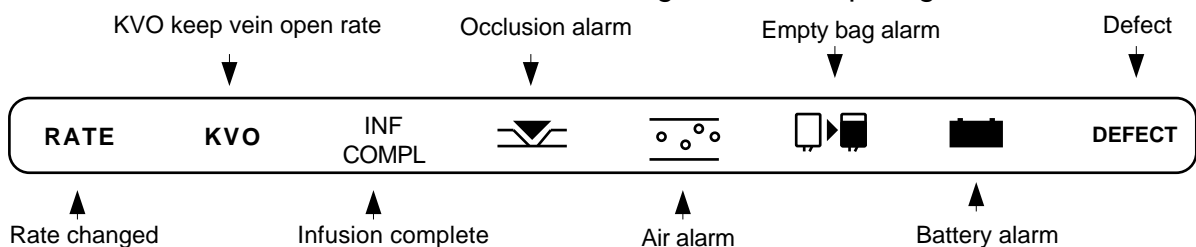

4.7. Power and running indicators (22)

These are indicated by the following:

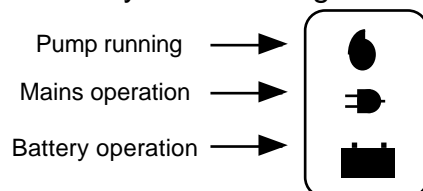

4.8. LCD window (20)

Various messages and infusion parameters are displayed in this window.

4.9. Technical description

The Volumed μ VP7000 is a microprocessor-controlled infusion pump with stepper motor drive and comprehensive software management function monitoring. The pump is operating range enables infusion rates from 0.1 ml/h to 1, 999 ml/h to be made. An internal rechargeable battery allows the unit to operate independently of the mains in emergencies or when used as a mobile unit. The mechanism is driven by a step motor via a toothed belt and friction spindle. All important operating parameters are clearly shown on an LED indicator. Setting the desired values is done via touch-pad keys. The unit is manufactured using the latest surface mounted control technology (SMD).

5. Warranty

Arcomed AG offers a twelve month warranty on each Volumed μ VP7000 volumetric pump effective from date of delivery.

The warranty covers the installation and replacement of faulty parts if caused by faulty assembly or materials. The warranty is rendered null and void if changes or repairs are carried out by persons who have not been authorized in writing to do so by Arcomed AG or Arcomedical Infusion Ltd and if the inspection and maintenance intervals are not observed.

The warranty does not cover the elimination of problems caused by incorrect operation, inappropriate handling or normal wear and tear,
The supplier only accepts responsibility for the safety, functional reliability and performance of the equipment providing that

- assembly, extension work, resetting, modification or installations are carried out by personnel authorized by him.
- the electrical system at the operating site meets IEC requirements.
- the unit is used in accordance with these Instructions for Use.

The information provided in this manual applies to the currently prevailing situation and is given in good faith. The manufacturer reserves the right to make modifications in the interest of technical progress.

5.1. Design changes

Arcomed AG endeavour to ensure that future improvements and modifications are compatible with earlier models.

NOTE: Always state the model, serial number and where applicable the colour of the unit in question when ordering spares.

6. Inspection and maintenance intervals Volumetric Infusionpump

Volumed® μ VP7000 (according MDD)

Interval: After 24 months or 10'000 h of use.

The following checks must be done by an engineer with sufficient technical background to comply with the safety regulations.

What to do	How / Equipment	Remarks	Result
Visual Check			
Housing		Physical damage	
External empty container detector (ECD) (Easy Clip)		Physical damage	
or Internal empty container detector (ECD) (especially spring)		Physical damage	
Door, door latch		Clean, function	
Stop-flow lever		Clean, function	
Cover for peristaltic blades		Physical damage	
Inscriptions, display		Readable, damage	
Display - LED		Function, display test	
Mains plug, fuses		Damaged, values	
Air in line		Physical damage	
Functional checks			
o <u>Spring plate</u>	manual	check free motion	
o <u>Pressure checks:</u>	IV-set filled with water, manometer & tubing		
o minimal mechanical pressure:	preload system with syringe to 0.7 bar 4 min. at rate 5 ml/h (press. limit 999 mbar)	watch manometer pressure always above 0.6 bar	o alternative test PTD-7000 p min =
o maximal mechanical pressure:	rate 400 ml/h (press. limit 999 mbar)	pressure always below 2.5 bar*	p max =
o <u>Pressure Sensor:</u>	rate 100 ml/h pressure limit 500 mbar make occlusion on set	alarm reaction within 20 sec \pm 10 sec	
o <u>Rate check:</u>	Rate 100 ml/h Total of 100 ml	\pm 5 % accuracy* Refer to trumpet curve (tech manual)	o alternative test VT-5000 % dev =
o <u>while running on 100 ml/h</u>			
o simulate missing drops	Take out drop chamber of ECD detector	Visual and acoustic alarm	
o simulate Air in Line	Air bubble (eg reverse drip chamber) in the line	Visual and acoustic alarm	
o check nurse call	e. g. open door while pump is running	alarms and switching signal at connector	
o (External pump stop	only Option RS 232C)		
<u>Electrical safety according to IEC 601</u>	Safety Tester IEC 601	IEC 601.1, section 19	
o Leakage current	75 μ A		
o Resistance protective conductor	100 mOhm		

The rates of the fuses must comply with the rates recommended by arcomed (producer):
Conventional transformer 230V :100 mA/250V, toroid transformer 230V: 250 mA/250V,
toroid transformer 115V: 500mA T/250V (IEC127/III/SEV 1064).

Caution: After any work on the pump (e. g. adjustment of programming, change of parts, any opening of the pump) this inspection must be made and all checks must be documented with the serial number of the pump.

* depending on set (eg. 3101P PVC 2.5 bar, \pm 5%, 8101P Silicone 1.5 bar, \pm 3%).

Serial Number:

Remarks:

Date /Signature:

7. Performance

7.1 Significance of trumpet curves for practical use

Trumpet curves indicate for 5 different observation windows the maximum and minimum mean values of the flow rate in ratio to the preset flow rate.

Known therefore is the discrepancy per time-window. For optimal use of the infusion pump Volumed® µVP7000, the trumpet curve is an important factor in deciding whether the pump can be used with the prescribed drug.

Volatile drugs with short therapeutic half life demand high accuracy.

For a drug where the plasma-half life is e.g. 1 min. discrepancy of the flow rate of 15% per minute would mean the same discrepancy for the plasma level. Therefore, a predictable constant impact of the drug would not be guaranteed.

Example:

Intravenous infused Insulin has a therapeutic half life of 15 minutes. A flow deviation of $\pm 15\%$ within 40 minutes would have at least the same (rather twice as much) influence on deviation of the plasma level and therefore on its impact.

This is unacceptable to physicians and nursing personnel.

It is important to know that the deviation in a short observation window depends strongly on the preset rate. The Volumed® µVP7000 has at a rate of 25 ml/h a deviation smaller than $\pm 2\%$ in a observation window of 2 minutes. With 5 ml/h the deviation in the same observation window is $\pm 7\%$, within 5 minutes it is $\pm 3\%$. Mean deviations are within $\pm 5\%$ (see also following table).

Table 1: Flow Accuracy of the Volumed® µVP7000 (typical values)

Rate (ml/h)	2 min		5 min		Testzeit (h.min)	Messzeit (h.min)
	Max	Min	Max	Min		
5.0	+6.93%	-5.99%	+3.08%	-3.45%		
25.0	+4.54%	-3.65%	+1.39%	-1.46%		
100.0	+0.60%	-1.17%	+0.28%	-0.76%		

Rate (ml/h)	eff. Rate (ml/h)	Abweichung (%)	Stand.-Abweichung (ml/h)	Testzeit (h.min)	Messzeit (h.min)
5.0	5.010	0.203	0.010	2.00	1.00
25.0	24.800	-0.399	0.200	2.00	1.00
100.0	101.182	1.182	1.182	2.00	1.00

File Name:

25ml/h IEC 7000

∅ Flow (2nd h):

25.788

∅ Error[%] (2nd h):

3.153

Rec. date:

11.2.2002

Rec. time:

10:54:24 Uhr

Rate (ml/h):

25.0

Evaporation:

0.00

Scans:

240

Interval (s):

30

Flow [ml/h]:

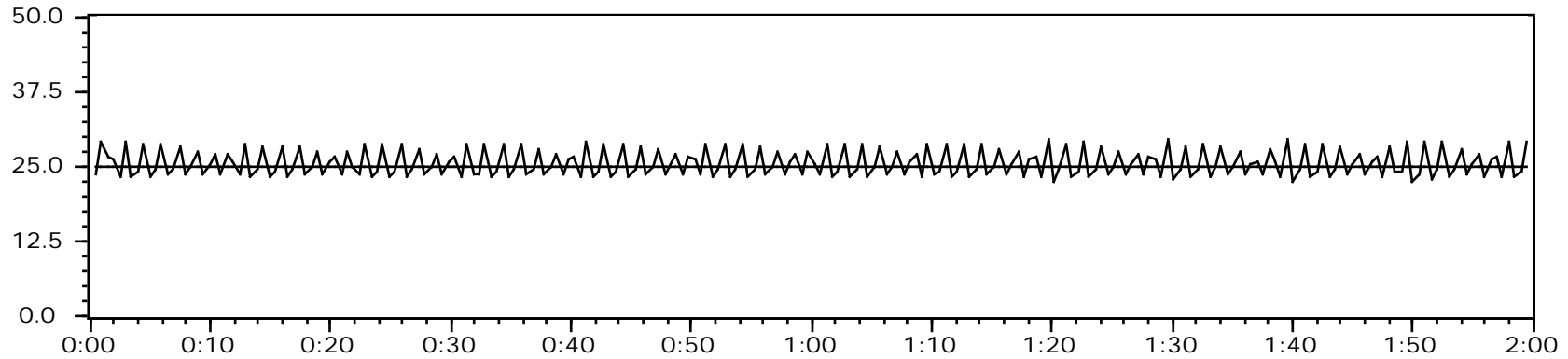

Trumpet Curve (2nd h):

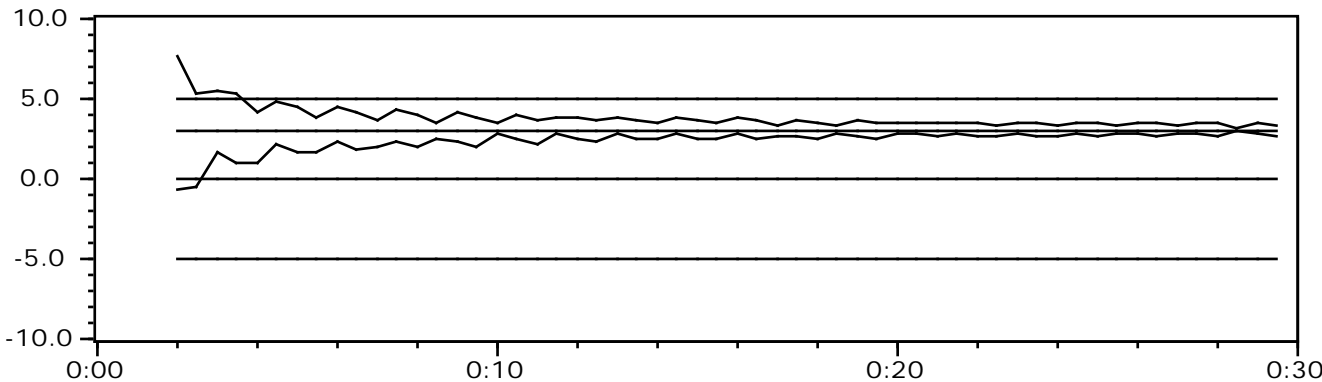

2 Min (max): 2 Min (min):

4.54 **-3.65**

5 Min (max): 5 Min (min):

1.39 **-1.46**

11 Min (max): 11 Min (min):

0.60 **-0.88**

19 Min (max): 19 Min (min):

0.57 **-0.37**

31 Min (max): 31 Min (min):

0.28 **-0.33**

File Name:

5ml/h IEC 7000

∅ Flow (2nd h):

5.010

∅ Error[%] (2nd h):

0.203

Rec. date:

19.2.2002

Rec. time:

10:07:52 Uhr

Rate (ml/h):

5.0

Evaporation:

0.00

Scans:

240

Interval (s):

30

Flow [ml/h]:

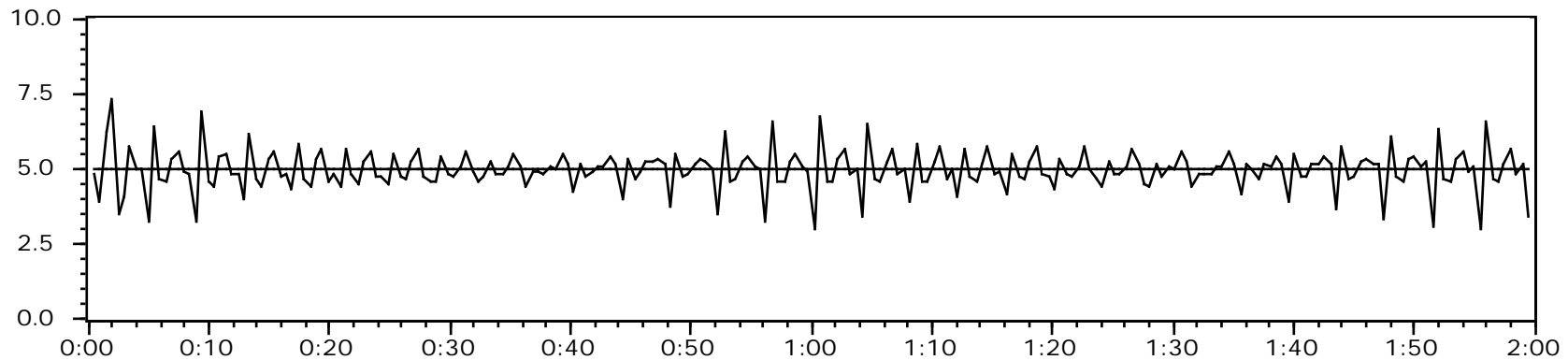

Trumpet Curve (2nd h):

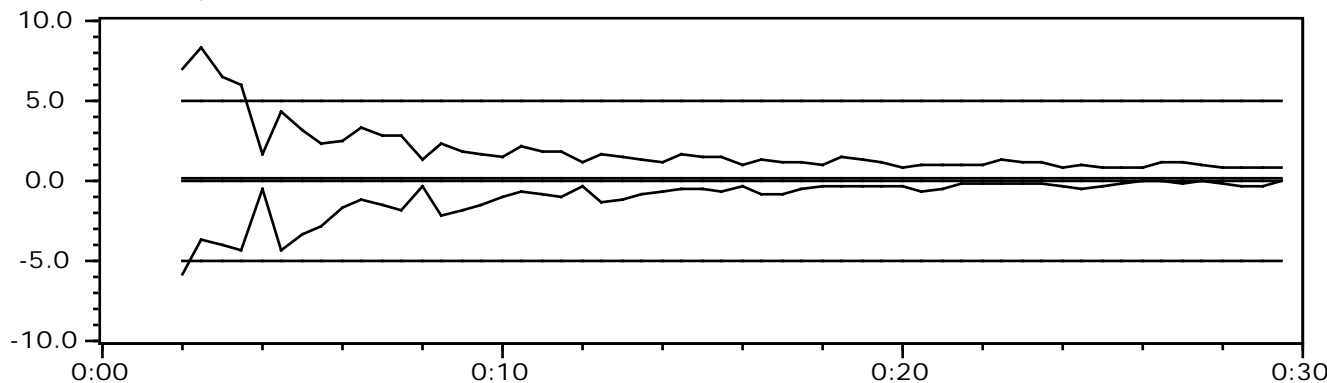

2 Min (max): 2 Min (min):

6.93 **-5.99**

5 Min (max): 5 Min (min):

3.08 **-3.45**

11 Min (max): 11 Min (min):

1.77 **-0.91**

19 Min (max): 19 Min (min):

1.23 **-0.52**

31 Min (max): 31 Min (min):

0.71 **-0.14**

8. TECHNICAL DESCRIPTION

8.1 Introduction

The microprocessor controlled peristaltic pump Volumed® μ VP7000 is supplied with a step motor drive and comprehensive software monitoring. The operating range of the pump allows rates from 0.1 - 999ml/h to be selected. An integrated, rechargeable battery permits mains-independent operation for emergencies or for ambulatory use.

A stop flow device is installed behind the door to prevent the infusion solution from flowing freely in the event of the pump door being opened inadvertently. The peristaltic system is driven by a step motor via a positive-engagement toothed belt, with the individual blade movements being controlled by an eccentric camshaft. These blades are fully protected by a rubber cover.

All important operating parameters are clearly reproduced on an LED display. The desired values are entered via a keypad.

All important operating parameters are clearly shown on two LED displays with an additional LCD for messages and various other data. Infusion parameters are set via touch keys which comprise a mechanical switch covered by a sealed membrane. The unit is manufactured using the latest surface mount technology (SMT).

In the circuit description that follows, reference is made to diagrams 1 to 3.

8.2. Circuit description

8.2.1. Microcontroller

Microcontroller D0 monitors the following signals:

Motor controller

The step motor drive D8 is controlled directly by the microcontroller and operates in chopper mode. The step motor operates in micro-steps to provide continuous and smooth delivery even at low flow rates.

Main shaft revolution pulses

A Hall sensor adjacent to the main shaft produces a pulse for each revolution of the shaft. In the microcontroller this is monitored by software on a frequency/time basis.

Watchdog

The external Watchdog in IC D2 monitors program run time. If the limits are not within the specified time, the semi-conductor relay VO interrupts power to the step motor. A fault is signaled to the microcontroller via the inverter D7.

The relay D10 is periodically switched off for a short period to test the watchdog and the correct functioning of the microcontroller is monitored. There is a second watchdog in the microcontroller.

Operating voltages

The supply voltage, the 5V logic supply rail and reference voltage are measured and monitored via disc resistors by the analog/digital converter in the microcontroller.

Mains/battery operation

The level of the operating voltage determines whether mains or battery operation is used.

Battery voltage

The battery alarm activates if the minimum operating voltage falls below the set limits during battery operation. The unit will be shut down in the case of exhaustive voltage discharge.

Logic rail voltage

The rail voltage is limited to a maximum of 5.5V by diode V20, and transistor V5 triggers the microcontroller and external Watchdog if 5.8V is exceeded. If the level reached is less than 4.5V, the integrated circuit D2 initialises the system.

Microcontroller D1 controls the following signals:

Step motor pulses

The step motor pulses are fed by the microcontroller from the quartz oscillator at a frequency corresponding to the rate set.

Watchdog

Watchdog D2 is triggered periodically after each program run.

Buzzer (audible alarm)

Dependent on the operating status the microcontroller activates the audible alarm trigger K1 via driver V9.

Alarm relay

Dependent on the operating status the microcontroller activates the alarm relay KO (Nurse call) via driver V8.

On/Off function

After start up the microcontroller triggers a hold of the semi-conductor relay V12 via the Power-Hold line. The supply voltage remains switched on. When operating the ON/OFF key or if the battery is discharged the microcontroller turns the supply voltage off via the semiconductor relay V12.

A/D converter

The microcontroller controls the internal A/D converter and measures the results.

Infra red interface

The microcontroller sends and receives data via IC's D10 to D12. The encoder D10 converts the signals to Standard IrDA 1.0. The unit can receive and transmit data from above (D11), below and to the rear (D12). This provides a wire-less connection between units mounted on top of each other.

EEPROM memory

Set values and important data are held in non-volatile memory D3 and/or recalled from there and remain available even when the pump is switched off. Even when the battery is fully discharged data is not lost.

SRAM memory and real time clock

IC D2 is an external SRAM and provides storage of a multitude of data. Simultaneously time and date can be read from the real time clock. The real time clock is buffered by a special battery and can work independently for up to 10 years even when the battery is fully discharged. The clock is only an indicator. An incorrect date or time will not effect the normal functioning of the pump.

8.2.2. Display

The operating status is depicted by the LED displays and illuminated pictograms. Display drivers M2, M3 and M4 are controlled by the peripheral IC's D3 and M1 and multiplexed by the microcontroller.

Rate	4-digit red numerals
Volume	5-digit red numerals
Alarm pictograms	red LEDs
Pump infusing	green LED
Battery operation	green LED
Mains operation	green LED

8.2.3. Inputting infusion parameters

All data inputs are made via keys which are periodically checked by the microcontroller. Only the ON/OFF key is connected separately and controls the start-up logic or releases a delayed shut-down via the microcontroller. The keys have the following functions:

<u>Function:</u>	<u>Key:</u>
Start -up/Switch off pump	ON/OFF
Rate setting	Rate 100 ml/h up/down Rate 10 ml/h up/down Rate 1 ml/h up/down Rate 0.1 ml/h up/down
Volume setting	Volume 1000ml up/down-Volume 0.1 ml up/down
Start/Stop	START/STOP pump
Prime/Bolus	Prime/Bolus key
Alarm silence/Option	2 MIN, Option
(In an emergency the audible alarm is silenced for 2 minutes)	

8.2.4. Power supply

Mains power is supplied via a toroidal transformer and the rectifier V10. In the event of a mains power supply failure, power is supplied without interruption by the internal battery. The charge switch V14 ensures the battery is constantly charged when the unit is connected to the mains (even when the unit is switched off). Relay V12 switches the supply voltage on or off.

On the one hand this function is controlled by the ON/OFF key and by a command from the microcontroller via the inverter D7.

On the other hand the microcontroller can in the same way trigger the shut down of the supply voltage. The circuit controller D13 produces the +5V rail voltage.

8.2.5. Monitoring

Microcontroller:	On start up the registers are checked for initial status and a RAM test performed.
Air bubbles:	50 µl detection limit, integration over 15 min., individual bubbles > 50 - 250µl adjustable Cumulative air alarm over 15 min adjustable 500-5000µl
Air detector test:	every 120 ms.
Pressure:	Continuous monitoring of pressure in the line in mbar or mmHg. Pressure limit 1...999 mbar/mmHg settable.
Empty bag detector: (Option)	Alarm after 330 µl no drops Alarm after 660 µl if < 5 drops Alarm after 660 µl if > 22 drops (adjustable)
Pump camshaft:	One revolution of the pump camshaft requires 246 step motor pulses. For each complete revolution of the pump camshaft, the hall pulse initiates a comparison with the number of step motor pulses supplied. Tolerance per revolution +/- 20% pulses.
Semiconductor relay:	Functional check every 62 msec.
Keypad:	A key actuated for more than 60 seconds triggers a fault signal.
Microcontroller:	On start up the registers are checked for initial status and a RAM test performed. Continuous ROM, RAM and CPU test during delivery.
Program run time: tolerance	External watchdog monitors programme run time; approx. ±15%.
Operating voltage:	Microprocessor monitors the following voltages: - mains/battery changeover threshold: 15V - Battery charged: 11V

Audible alarm repeat: - Battery discharged: 9V
 - 5V rail monitoring < 4.5V: fault signal > 5.8V: fault signal
 - A/D converter: defect >2.5%: fault signal
 On 0.6 sec Off 3.0 sec

Other functions: - Audible alarm in standby mode

9. Trouble shooting

When a DEFECT signal is given a fault code is displayed automatically. In the Volume ML (12) window a 2-digit figure appears and the cause of the fault indicated is listed in the table that follows. When a fault occurs the code appears automatically as F-xx.

Code (Volume ML)	Meaning:	Measure:
0	Program sequence	Replace main PCB
2	Step motor too fast	Replace main PCB
3	Step motor too slow	Check drive
4	AD converter fault	Replace main PCB
5	Stop flow clamp fault	Check stop flow driver
6	Supply voltage	Replace main PCB
7	Key blocked	Replace display PCB
8	Watchdog Test	Replace main PCB / Lithium battery
9	CRC Test EPROM	Replace EPROM
10	Run time	Replace main PCB
11	CRC Test EEPROM	Check all EEPROM values
12	Watchdog test 1	Replace main PCB / Lithium battery
13	Initial CPU test	Replace main PCB
14	Register test	Replace main PCB
15	SRAM test	Replace main PCB
16	Bit-walk Test RAM	Replace main PCB
17	CPU Test (Instruction set)	Replace main PCB
18	Stop flow (battery)	Replace main PCB
19	Stop flow (mains)	Replace main PCB
>20	combined errors	Check pump / replace main PCB

10. Replacement of parts

The Volumes symbol μ VP7000 may only be repaired by ARCOMED AG or persons officially authorised in writing by Arcomed AG or Arcomedical Infusion Ltd to do so.

In the event of a warranty claim please send the unit to the address shown in Chapter 1.1.

CAUTION: The unit must be switched off and the mains connection removed before commencing repairs.

a) Dissassembly of case:

Remove the two tie screws in the pole clamp on the rear of the unit and separate the two sections of the case. First check and record the positions of all connectors and disconnect those between the front and rear assemblies where necessary. Ensure that all connectors are correctly positioned and inserted when reassembling the unit (see Topography Main PCB).

b) Removal of the main PCB:

Undo the four screws between the main PCB and the chassis.

CAUTION: Sensitive electronic parts can be damaged by static voltage if the main PCB is handled incorrectly. Be sure that correct cable connections are made when reassembling unit (refer to socket positions on the leaflet Main PCB Topography).

The connector PCB is also fixed by two screws.

c) Removal of the display PCB and covers:

Undo the eight screws at the rear of the door which hold the door assembly together. Undo the five screws between the PCB and the front door section and carefully remove the PCB. After reassembly ensure the correct key functioning.

d) Removal of the mechanical assembly (drive):

After removal of the main PCB undo the mounting screws and spacers holding the mechanical assembly to the case. Carefully withdraw the whole drive and disconnect the hall cable. The mechanism can then be removed from the case. Re-assemble in reverse order. Check that the cables are connected firmly (front print, hall sensor, pressure sensor) and the DC motor cable is fed through the opening in the side plates. When assembling the main pcb, check the stepper motor cable to be in the corresponding space.

11. Volumed µVP7000: List of spare parts

Please quote the serial number of the pump when ordering.

Part no.	Description	Assy	Rev.	Material
70000	Case rear	Back 1	BC00	ABS
70010	8mm safety ring	Back 1, Front 1	BC00	steel
70020	Rubber foot - blue	Back 1, Front1	BC00	Santoprene
70030	Screw M3/10	Back 5	BC00	steel
70050	Nut M3	Door 2	BC00	steel
70070	Mains connector	Back 5	BC00	plastic UL94V-0
70080	Plastic screw 3 x 10	Back 3, Front 5	BC00	steel
70100	Fuse T200mAT/250V	Back 5	BC00	glass/steel
70110	IR window	Back 6	BC00	polyamide
70120	Cylinder screw M4x6	Back 4	BC00	steel
70131	Toriodal transformer 9.3VA 230V	Back 4	BC00	ABS / copper
70140	Toriodal transformer 8.5VA/110V	Back 4	BC00	ABS/Cu
70160	Tie 6000	Back 7	BC00	aluminium
70170	Handle 6000	Back 7	BC00	steel
70180	Bolt 4x20	Back 7	BC00	steel
70200	Ferrite Transformer	Back 4	BC00	ferrite
70270	Mask LED	Door 3	BC00	ABS
70280	Foil 1 x 3 LED	Drive9/Door3	BC00	PVC
70320	Plastic screw 2.5 x 6	Door 2, Door 6	BC00	steel
70370	Plastic screw 2.5 x 16	Door 7	BC00	steel
70470	Drive pully 13MXL complete	Drive	BC00	POM
70490	Cylinder screw M3x8	Front 9, Front 10	BC00	steel
70550	Magnet ø3 x 3	Drive 12	BC00	magnet
70570	Drive pully 32MXL complete	Drive 12	BC00	POM
70585	Pulley No 5	Drive, StopFlow	00	POM
70770	Plastic screw 2.2 x 8	Drive 6, Front 3	BC00	steel
70800	Gear weel	Drive 10	BC00	steel
70810	3m nurse call cable	final	BC00	cable
70830	Ferrite Nurse Call	Final	BC00	ferrite
70860	Micro fuse T1A battery	final	BC00	electronics
70901	EPROM M 27 C 512	Front	BC 25	electronics
70911	Main PCB 6000/ 4 BC 25 (extended Eprom 512)	Front	BC25	electronics
70920	O-ring tie	Back	BC00	Santoprene
70940	Spacer M3x40	Front 2	BC00	steel
70960	Door rod	Front 2	BC00	steel
71160	Battery 9.6V/1.85Ah	Front 9	BC00	NiMH
71170	Battery holder	Front 9	BC00	steel
71180	Mounting plate back	Front 9	BC00	steel
71210	Lithium battery time keeper	DA mit Hauptprint	BC00	Litium
71230	Labels ø8mm	final	BC00	PVC
71240	Screw M3/10	Back 5	BC05	steel
71250	Cylinder screw M3x4	Back 5	BC05	steel
71260	Screw M3x4	Back 5	BC05	steel
71271	Seal mains cable	Back 5	BC55	steal, rubber
71690	Backlight	Displayprint	BC00	electronics
71700	LCD Display	Displayprint	BC00	electronics
75000	Case front	Front	BC00	ABS
75010	Door external part	Door	BC00	POM
75020	Door internal part	Door	BC00	POM
75030	Lever left and right	Door	BC00	POM
75040	Bearing plate	Front	BC00	POM
75050	Plate air in line detector	Front, Door	BC00	POM
75060	Plate pressure sensor	Front	BC00	POM

75070	Apdapter PVC 7000	Front	BC00	ABS
75080	Case Stop Flow	StopFlow	BC00	POM
75090	Stop Flow Adapter	StopFlow	BC00	POM
75100	Stop Flow Adapter standard	StopFlow	BC00	POM
75110	Actuator Stop Flow	StopFlow	BC00	POM
75120	Side Plate 7000	pump bloc	BC00	POM
75130	Slider 7000	pump bloc	BC00	POM
75140	Back plate 7000	pump bloc	BC00	POM
75150	Mounting plate 7000	Back 2, StopFlow	BC00	PVS-G
75160	Frontpanel 7000	Door	BC00	PVS-G
75170	Transformer mounting plate	Back 4	BC00	steel
75180	Camshaft 7000	pump bloc	BC00	steel
75200	Door support	Door	BC00	steel
75210	Chassis pump bloc 7000	pump bloc	BC00	steel
75220	Door hinge (right)	Front	BC00	steel
75230	Door hinge (left)	Front	BC00	steel
75240	Clutch 7000	pump bloc	BC00	Brass
75250	Motor connection 7000	pump bloc	BC00	Brass
75260	Joint cable 7000	door	BC00	Rubber
75270	Spacer M3 x 50	Front	BC00	steel
75280	Insert thread M2 x 3	StopFlow	BC00	Brass
75290	Screw M1.6 x 8	StopFlow	BC00	Iron
75300	Screw M2 x 12	StopFlow	BC00	Iron
75310	Screw M2 x 8	StopFlow	BC00	Iron
75320	Screw M2 x 4	StopFlow	BC00	Iron
75350	Ball bearing ø10/ø3 x 4	pump bloc	BC00	Steel
75360	Screw PT 4 x 25	pump bloc	BC00	steel
75370	Screw PT 4 x 30	pump bloc	BC00	steel
75380	Washer M3/3.2/9/1	pump bloc	BC00	steel
75390	Screw M3 x 10	pump bloc	BC00	steel
75400	Spacer tube 4*0.4*4	pump bloc	BC00	steel
75410	Spacer tube 4*0.4*5	pump bloc	BC00	steel
75420	Spacer tube 4*0.4*6	pump bloc	BC00	steel
75430	Hall pcb complete 7000	pump bloc	BC	electronics
75440	Bolt 1.5 x 10	Door	BC00	steel
75450	Screw for plastics 2.5 x 12	door	BC00	steel
75460	Screw for plastics 2.5 x 10	Door, Front	BC00	steel
75470	Screw for plastics 2.2 x 4.5	Door, Front	BC00	steel
75480	Foil 1 x 1 LED	Door3	BC00	PVC
75490	Display pcb 7000	Door	BC00	electronics
75500	Connector PCB 12V 7000	Back	BC00	electronics
75510	Front PCB 7000	Front	BC00	electronics
75520	Pressure sensor 7000	p sensor	AC105	electronics
75530	Spacer M3 x 8	Front	BC00	steel
75540	Screw M3x12	Front	BC00	steel
75550	Bolt 4 x 16	Front	BC00	steel
75560	Stepper Motor 7000	Pump bloc	00	iron / copper
75565	Stepper motor 7000	Pump bloc	BC00	Iron / cupper
75570	DC Motor 7000	StopFlow	00	iron / copper
75580	Motor belt 40 MXL 7000	Pump bloc	00	rubber
75590	Motor support 7000	pump bloc	BC00	steel
75600	Spindle for door 7000	Door	BC00	steel
75610	Main PCB 7000	Front	BC00	electronics
75620	Clutch complete 7000		BC00	Brass/rubber
75630	Tube seal	Dichtung Exzenter	BC00	NBR
75650	Sticker Front view µVP7000	Front	BC00	PVC
75660	Sticker Condensed instr. µVP7000-D	final	BC00	PVC
75670	Sticker Condensed instr. µVP7000-F	final	BC00	PVC
75680	Sticker Condensed instr. µVP7000-E	final	BC00	PVC

92201	Pump housing (blade housing)	pump bloc	AC040	POM
92461	Blade	pump bloc	AC040	POM
93980	Ball bearing dia. 6/19x6	pump bloc	BC00	stell
98100	Spacer M5/60mm thread inside	final	BC00	iron
98275	M3 / 3,2 safety ring	Pump bloc	BC00	iron
98435	Sticker Battery	Front	BC00	PVC
98635	Cover P-Sensor (blue)	p sensor	BC00	POM
98641	Adapter P-Sensor	p sensor	BC00	ABS
98643	Adapter P-Sensor PVC	p sensor	BC00	ABS
98780	Magnet EC	Easy Clip	AC045	Magnet
98932	Rubber cover for peristaltic blades	pump bloc	AC040	rubber
99290	Plate ultrasonic for air detector	air detector	BC00	brass
99360	PXE plate	air detector	BC00	quarz
99565	screw M3x4	back	BC00	iron
99730	Eccentric disk	pump bloc	BC00	POM
99810	Screw 3.9/9.5	pump bloc	BC00	iron
99820	Screw 3.9/13	pump bloc	BC00	iron
99950	Silent bloc 8/8	pump bloc	BC00	bronze/rubber

Drawings

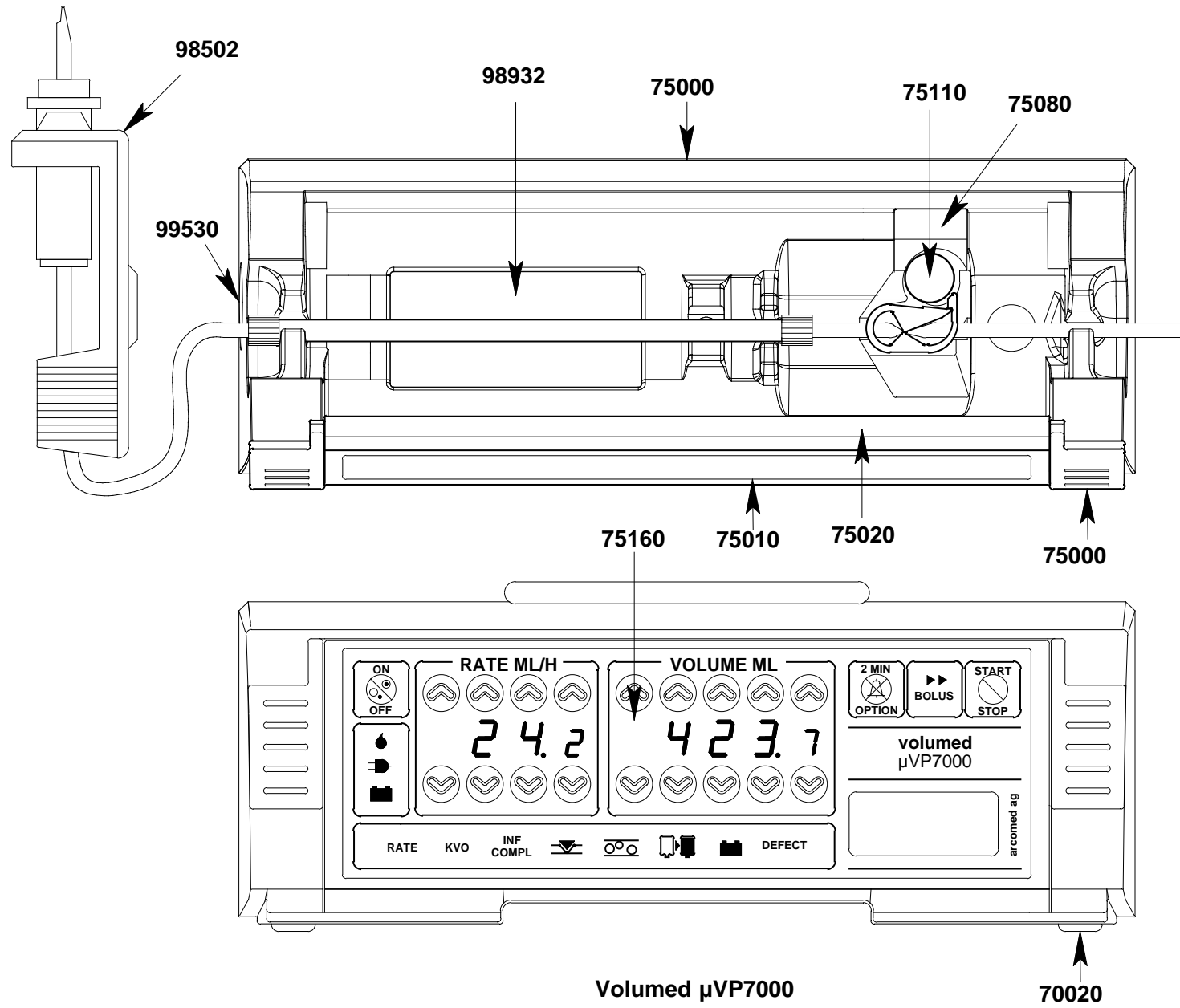

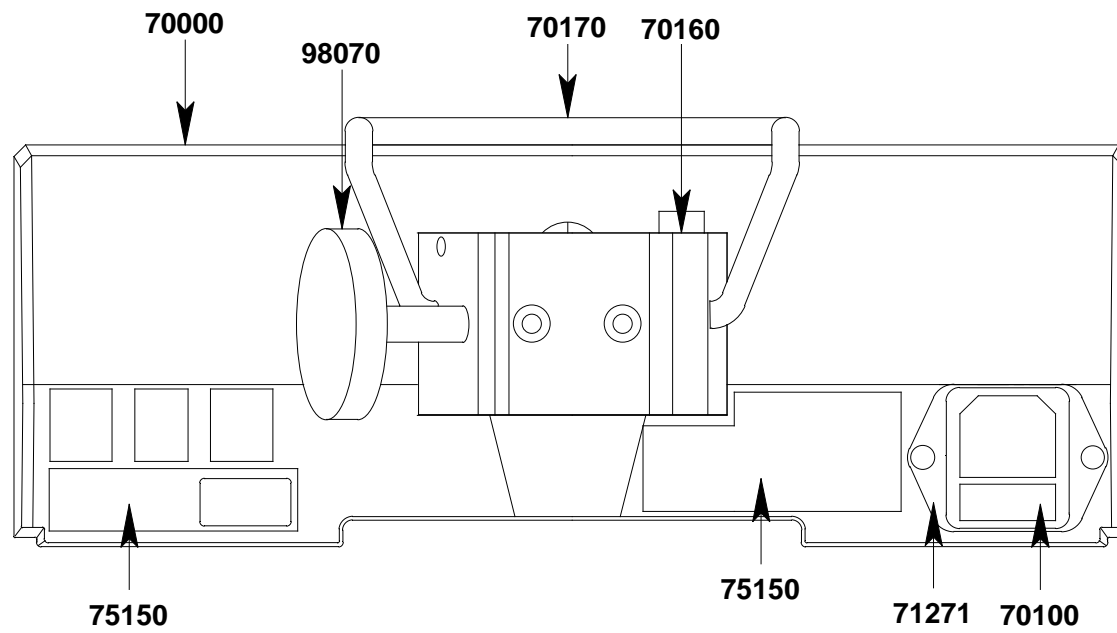

Volumed μ VP7000

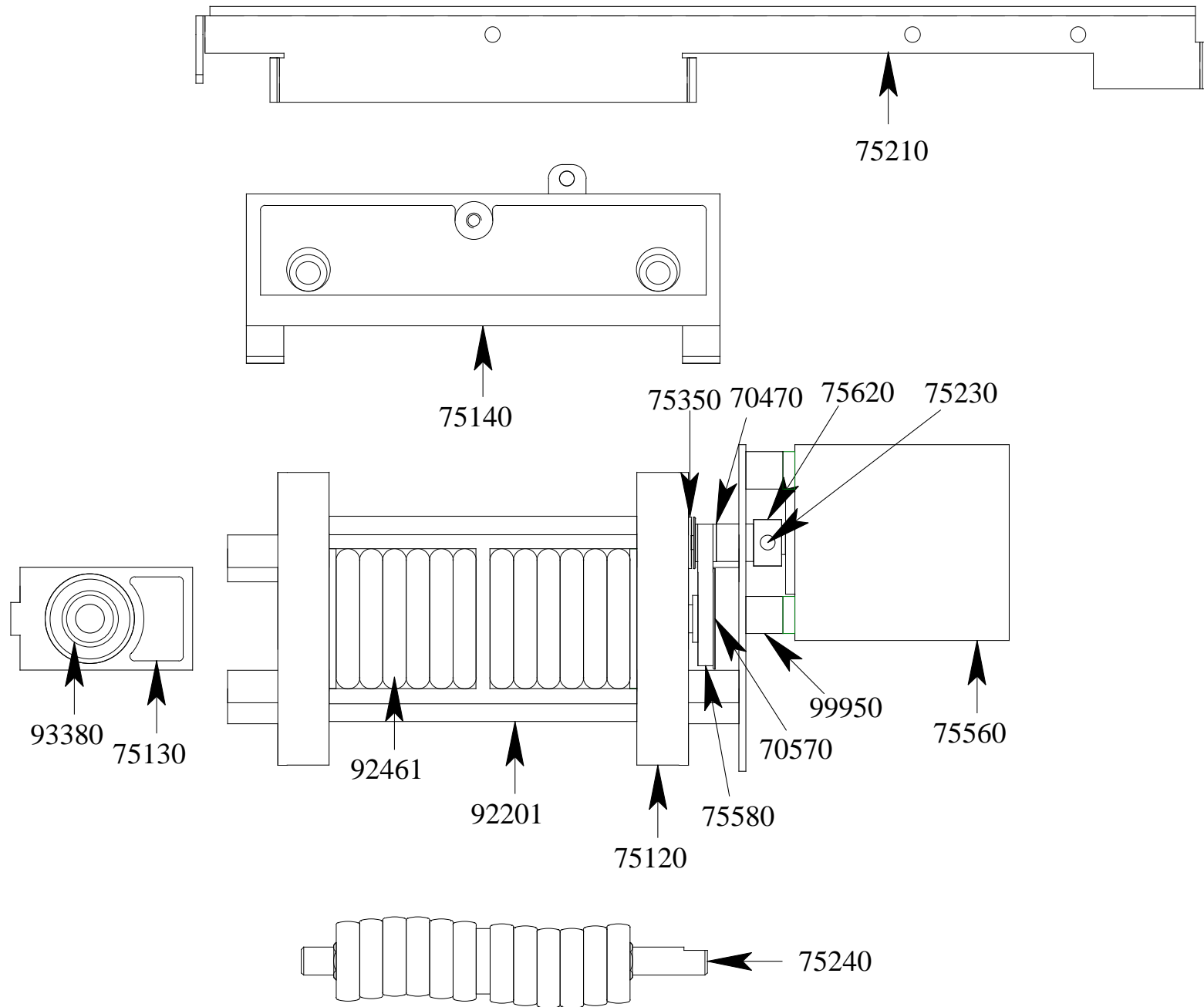

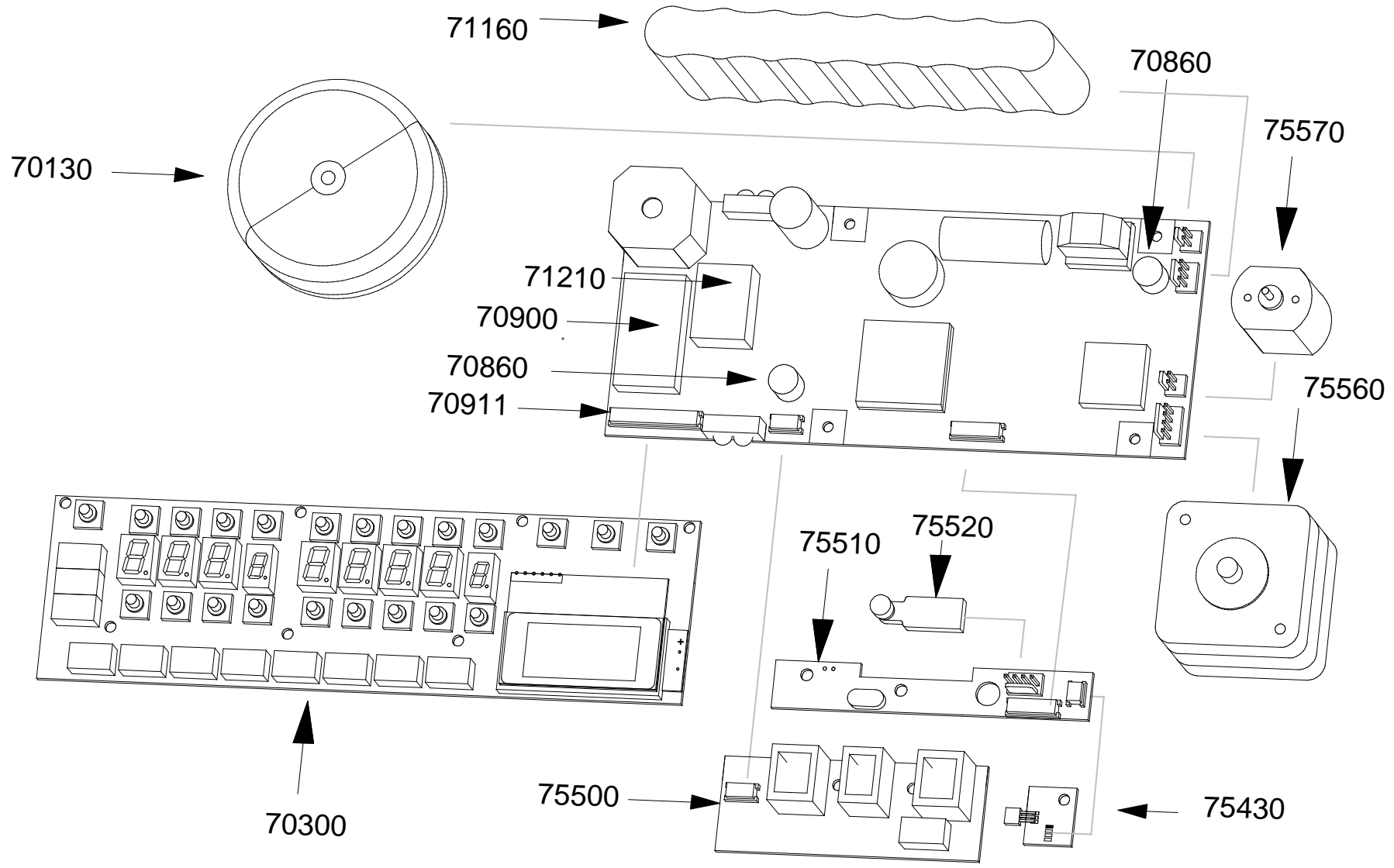

Schematics

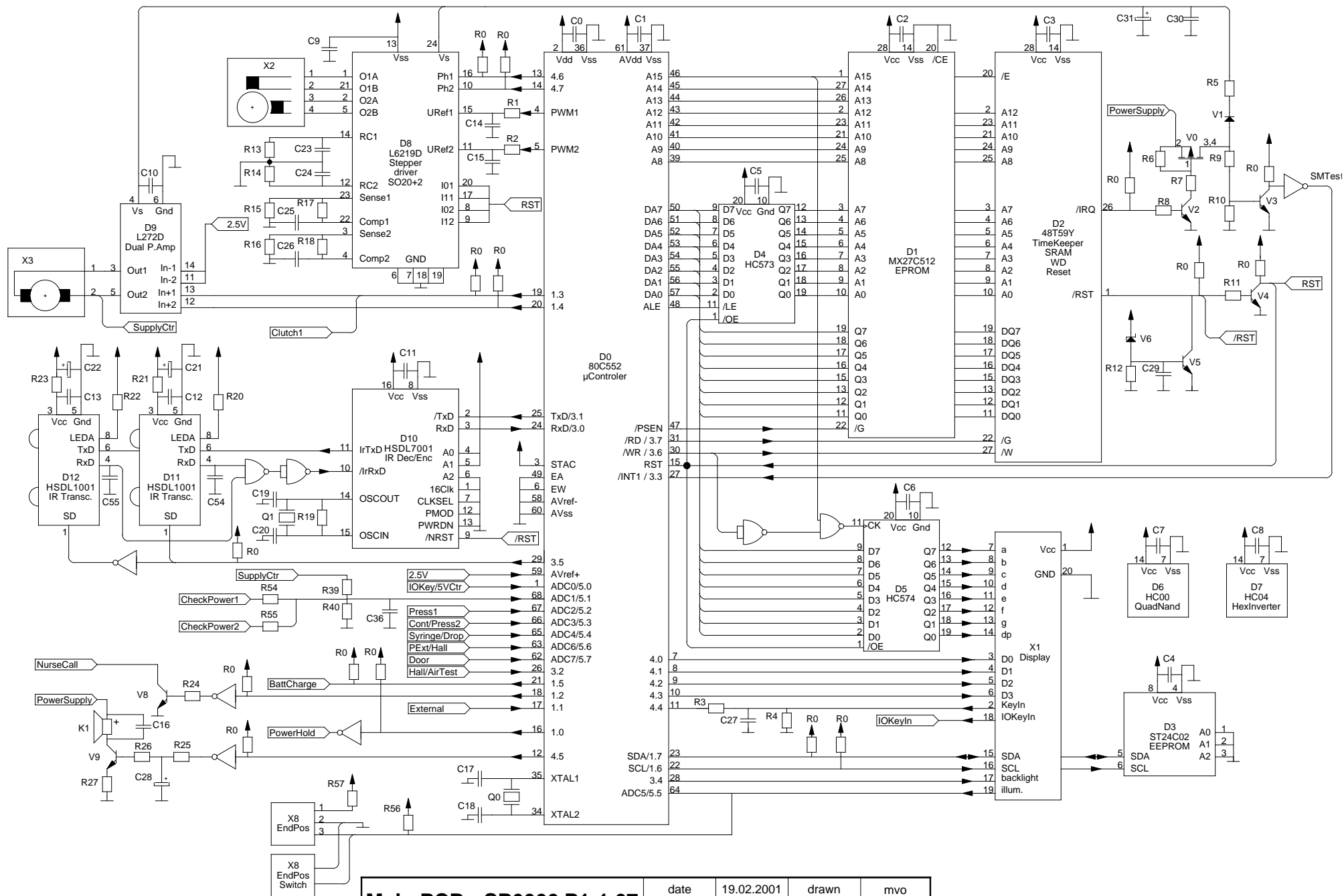

Main PCB µSP6000 P1-1.07

date	19.02.2001	drawn	mvo
scale [mm]	1:1	checked	
copyright arcocomed - confidential	material: (PCB)	Nr. 6001-0101	

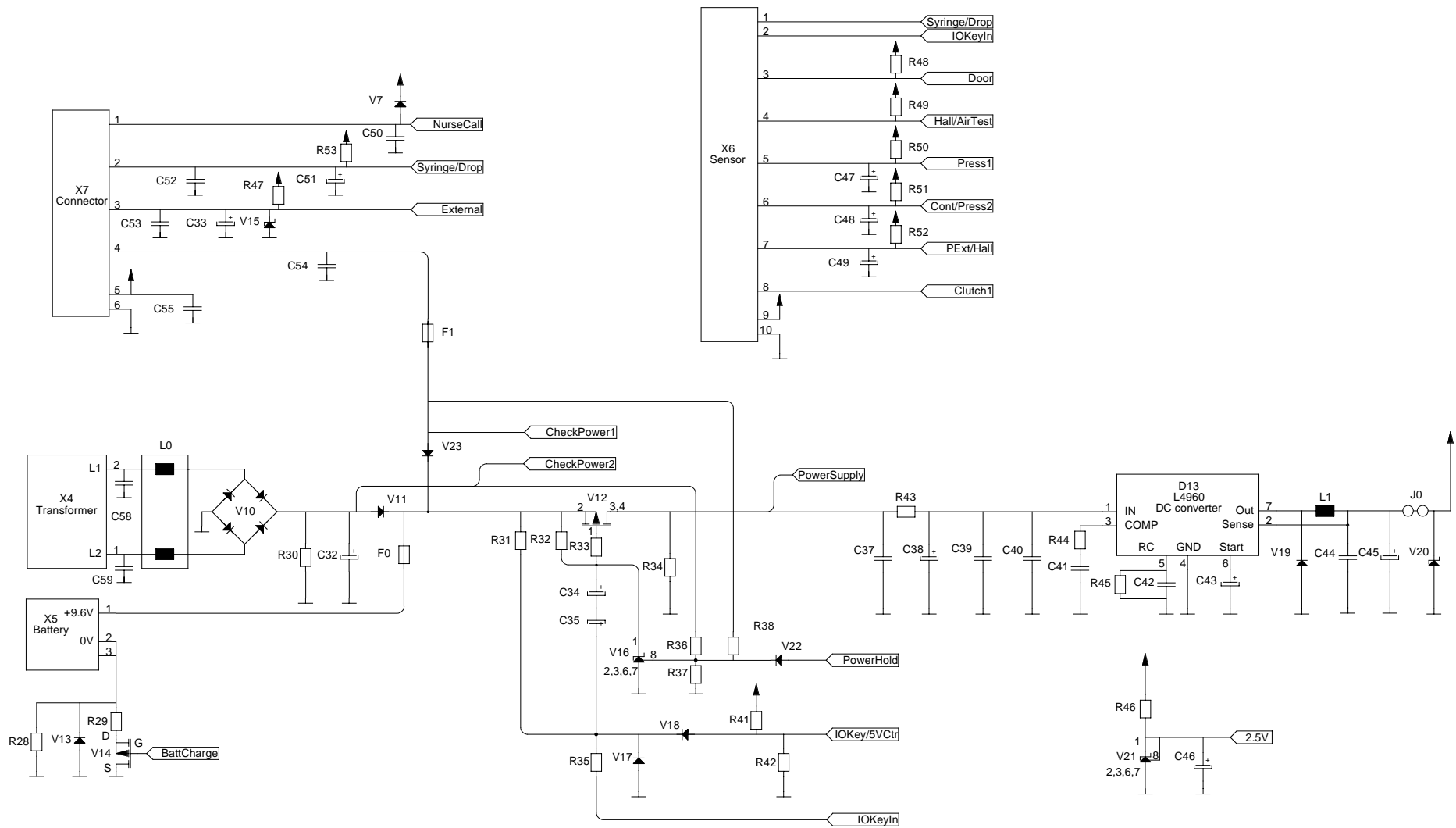

Main PCB μ SP6000 P2			
date	2.11.2000	drawn	mvo
scale [mm]	1:1	checked	
copyright arcomed - confidential	material: (PCB)	Nr. 6001-0102	

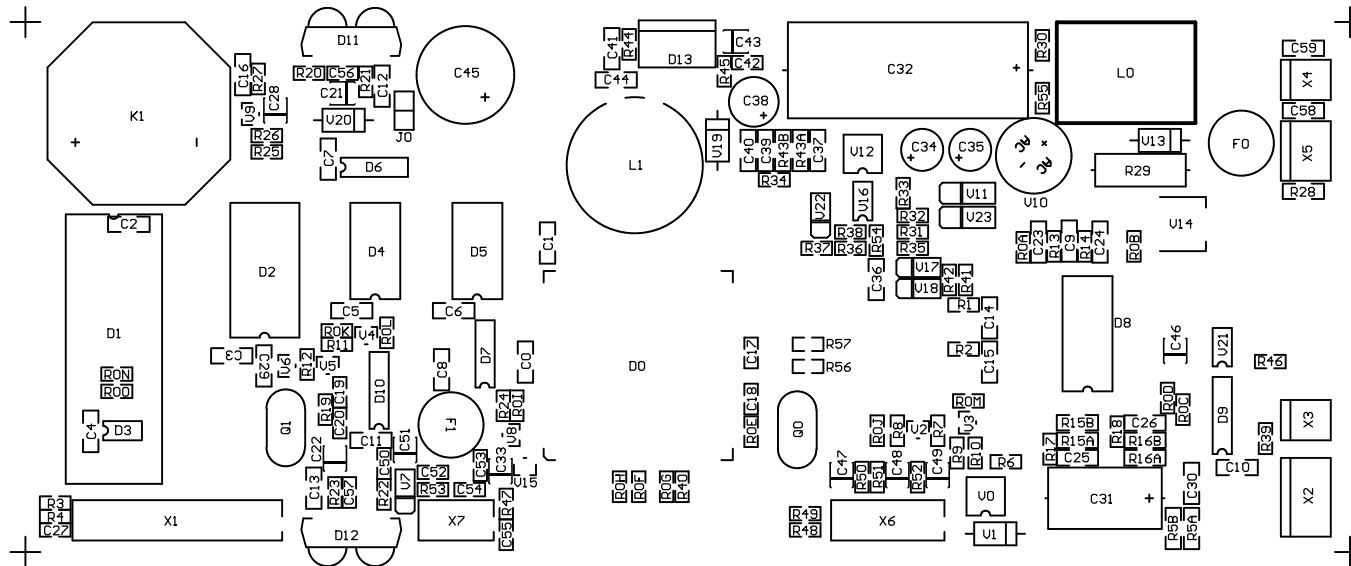

Die im Mech. Layer1 markierten Loecher (9 Stk.) nicht durchkontaktieren.

Material: FR4, durchkontaktiert, 35µm Cu			
MAIN PCB uSP6000	980107/007	29.11.2001	BU
Mechanical Layer 4		FILE:980100_7.pcb	
		SCALE: 1.00	
/FTEST		IFTEST AG	
		SCHWIMMBADSTRASSE 43	
		CH-5430 WETTINGEN	
		PHONE 41-56-437-37-37	
		FAX 41-56-437-37-50	

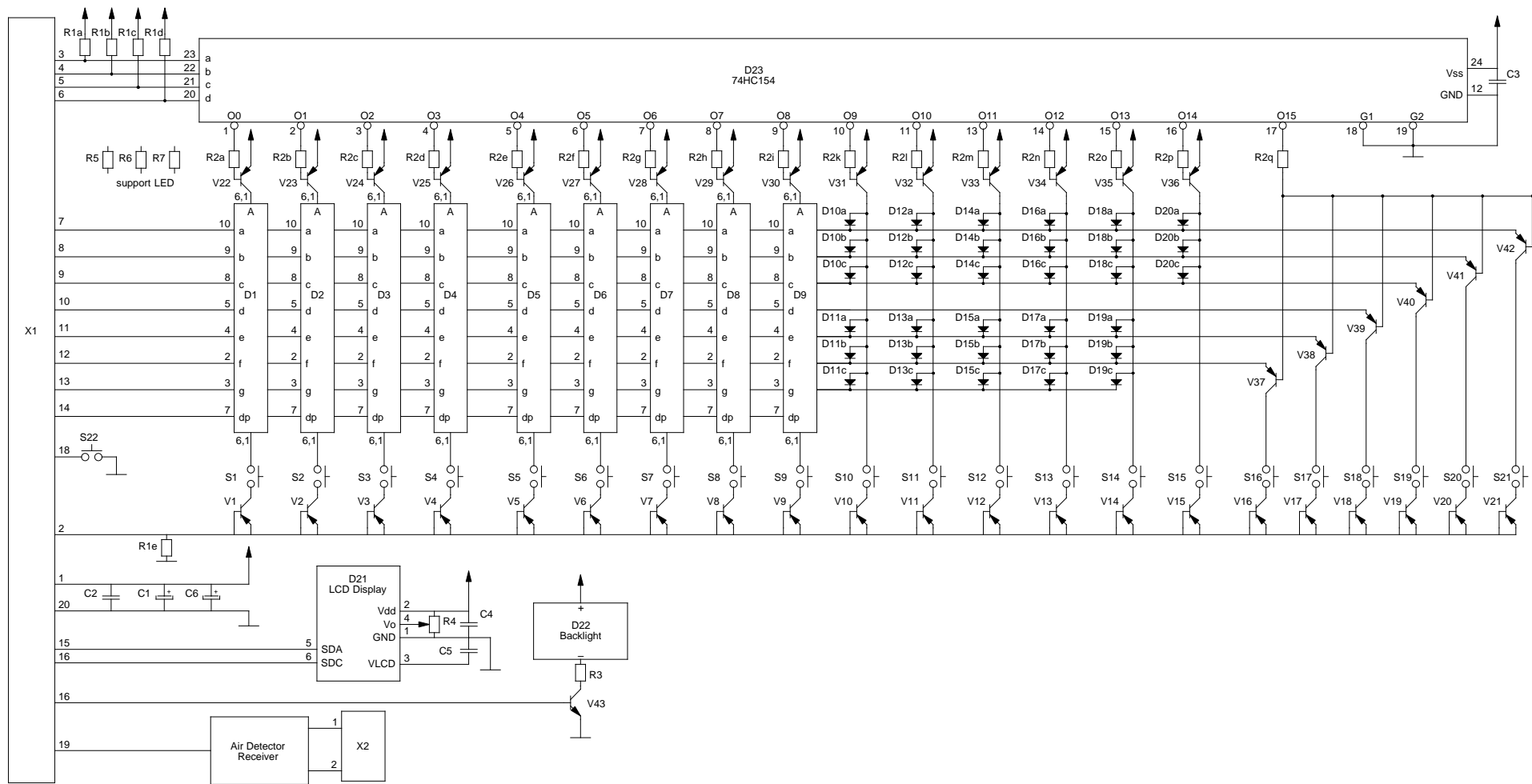

Schematic Display PCB μVP7000			
date	2.11.2000	drawn	mvo
scale [mm]	1:1	checked	
copyright arcocomed - confidential	material: (PCB)	Nr. 7001-0107	

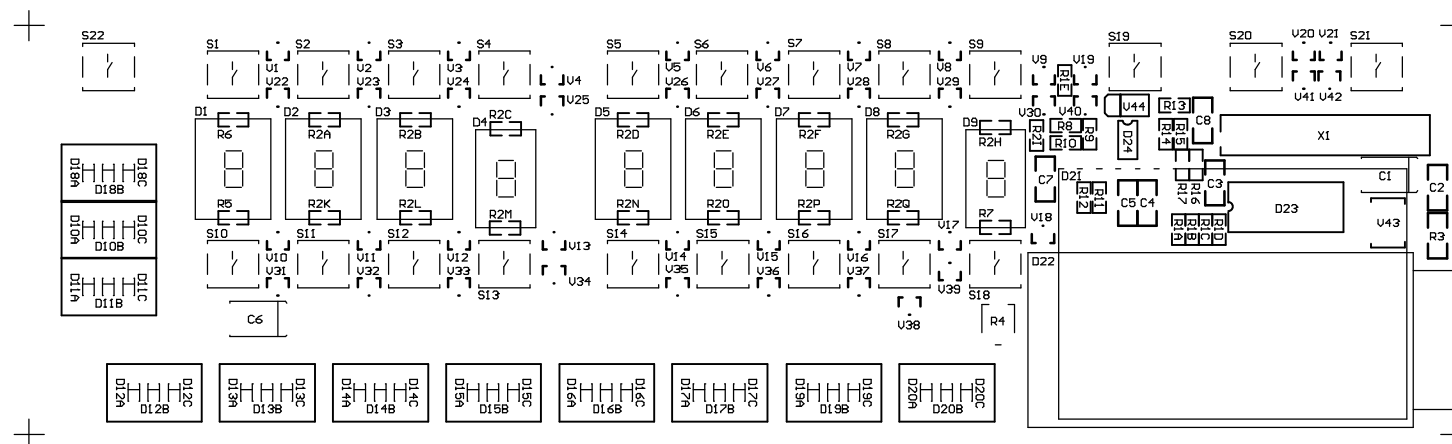

DISPLAY uVP7000	990207/002	07.01.2002	GOE
Top Overlay		FILE:990200_2.pcb	
		SCALE: 1.00	
DED electronic		DED AG	
		PUMPWERKSTRASSE 15	
		CH-8105 REGENSDORF	

Die im Mech. Layer 1 markierten Loecher duerfen nicht Durchkontaktiert werden.

Front PCB

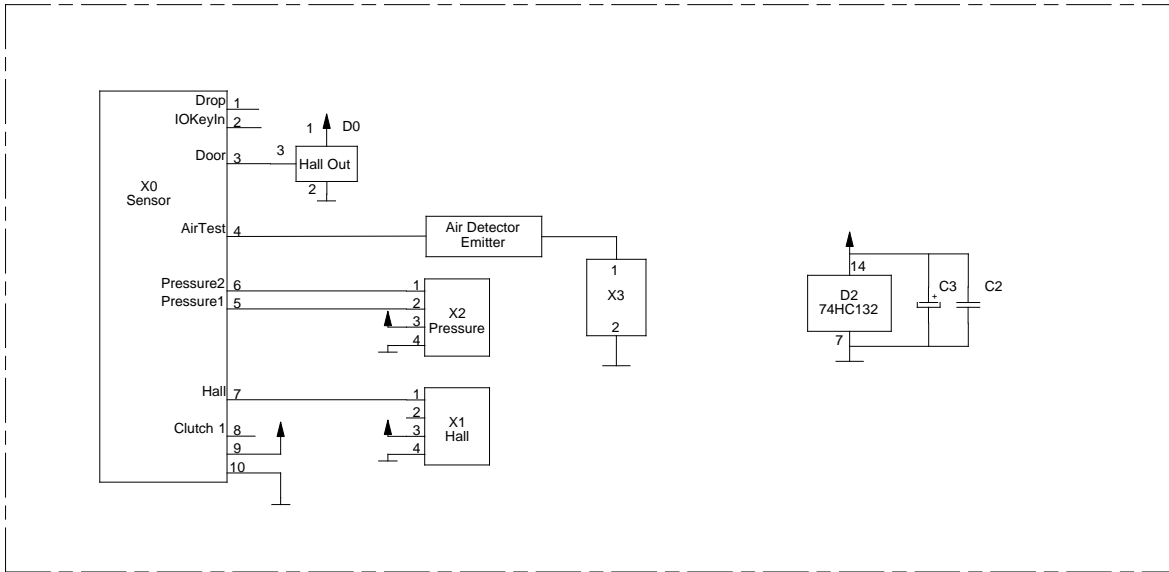

Hall PCB

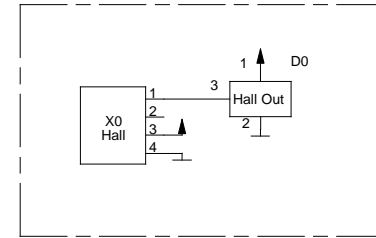

Connector PCB

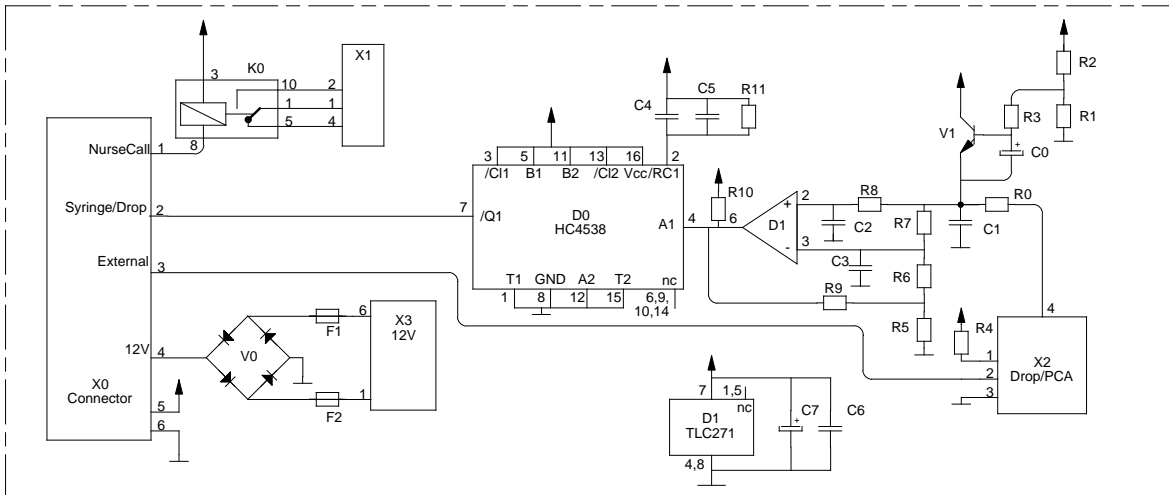

Sensor PCB μ VP7000 1.01

date	3.7.2001	drawn	mvo
scale [mm]	1:1	checked	
copyright arcomed - confidential	material: (PCB)	Nr. 7001-0103	

FRONT 7000 V1.01/05.07.2001
 Component Layout Top

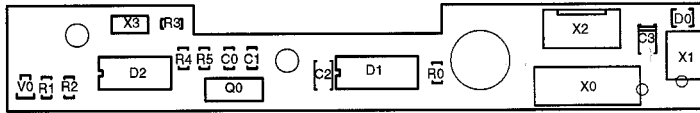

Connector 7000, 1.00/3.11.2000
 Component Layout

