

Microlab ML3500 - ServiceManual

050-13 Iss. 1.0 June 2000

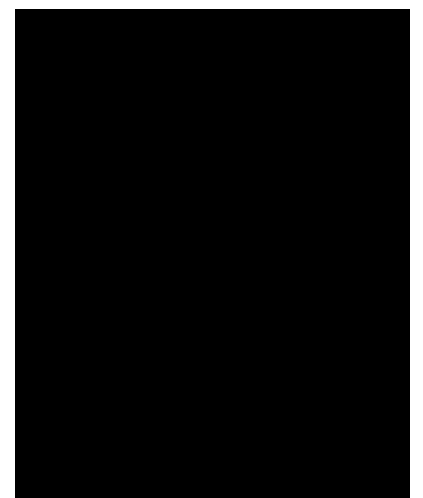

Contents

Exploded Isometric View	3
System Overview.....	4
Figure 1	4
Transducer.....	5
Figure 2	5
Disassembling the MicroLab for Repairs.....	6
Reassembling the Microlab after repairs.....	6
Circuit Description	
Circuit Overview	7
Processor Control Section	7
Address Bus.....	7
Ram Address Lines.....	7
Reset.....	7
Keypad.....	7
Real Time Clock.....	8
Display	8
Serial Interface.....	8
Battery Monitoring.....	8
Printer Driver.....	8
Power Supply.....	9
Printer Mechanism.....	9
Transducer Interface.....	9
Parts List.....	10
Technical Support.....	13
Fault Analysis.....	14
Circuit Diagrams.....	15
Circuit overview.....	15
Processor Section.....	16
Power supply.....	17
Printer Driver.....	18
PCB layer 1.....	19
PCB layer 2.....	20

Exploded Isometric View

Exploded Isometric View

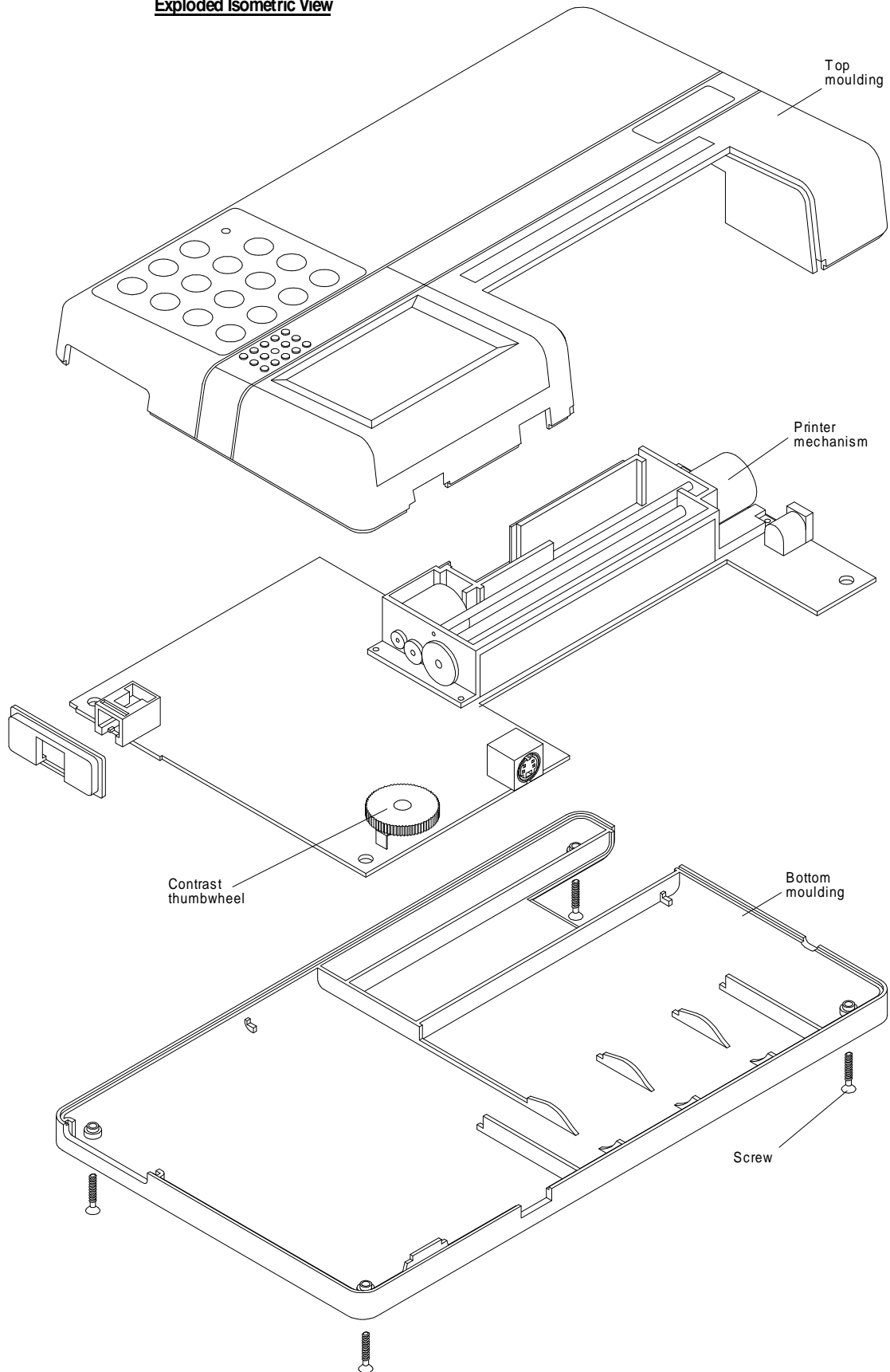

MicroLab - System Overview (Fig. 1)

The Micro Medical MicroLab is a data recording spirometer consisting of a microcomputer unit (1) incorporating an LCD graphic display, data entry keypad, RS232 serial interface and all associated circuitry. This is supplied with a digital volume transducer (2), disposable mouthpieces, transducer holder (3) and mains adapter (4). The MicroLab is powered by internal rechargeable Nickel Cadmium cells or by the mains adapter supplied (4).

When testing a subject the transducer is inserted into the holder which is plugged into the microcomputer unit. The digital volume transducer is used to measure the subjects expired flow and volume in accordance with the operating manual.

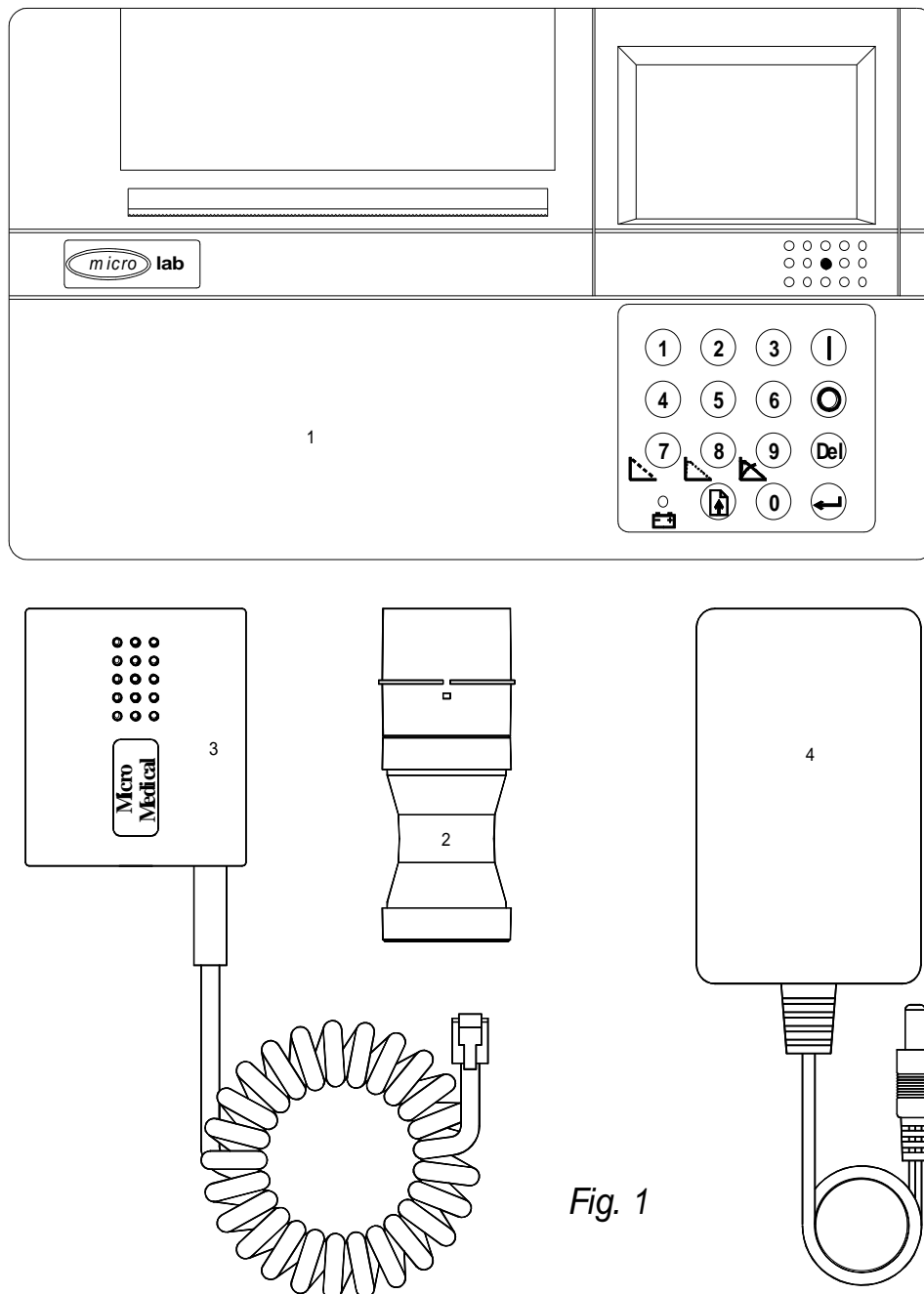

Fig. 1

Transducer (Fig. 2)

The Micro Medical digital volume transducer consists of an acrylic tube with a vane positioned between two swirl plates. The low inertia vane is attached to a stainless steel pivot which is free to rotate on two jewelled bearings mounted at the centre of the swirl plates. As air is passed through the transducer a vortex is created by the swirl plates which causes the vane to rotate in a direction dependant upon the direction of air flow. The number of rotations is proportional to the volume of air passed through the transducer and the frequency of rotation is proportional to the flow rate. The transducer housing consists of a main body which contains a pair of light emitting diodes (LED's) and phototransistors. The transducer is fixed to the mouthpiece holder which pushes into the main body and is captured by an "O" ring seal. The LED's produce infra red beams which are interrupted by the vane twice per revolution. This interruption is sensed by the phototransistors. The output from the collector of each phototransistor will be a square wave with a phase difference between the two of + or - 90 degrees depending upon the direction of flow.

There is no routine maintenance required for the transducer other than cleaning according to the instructions in the operating manual.

Micro Medical Digital Volume Transducer

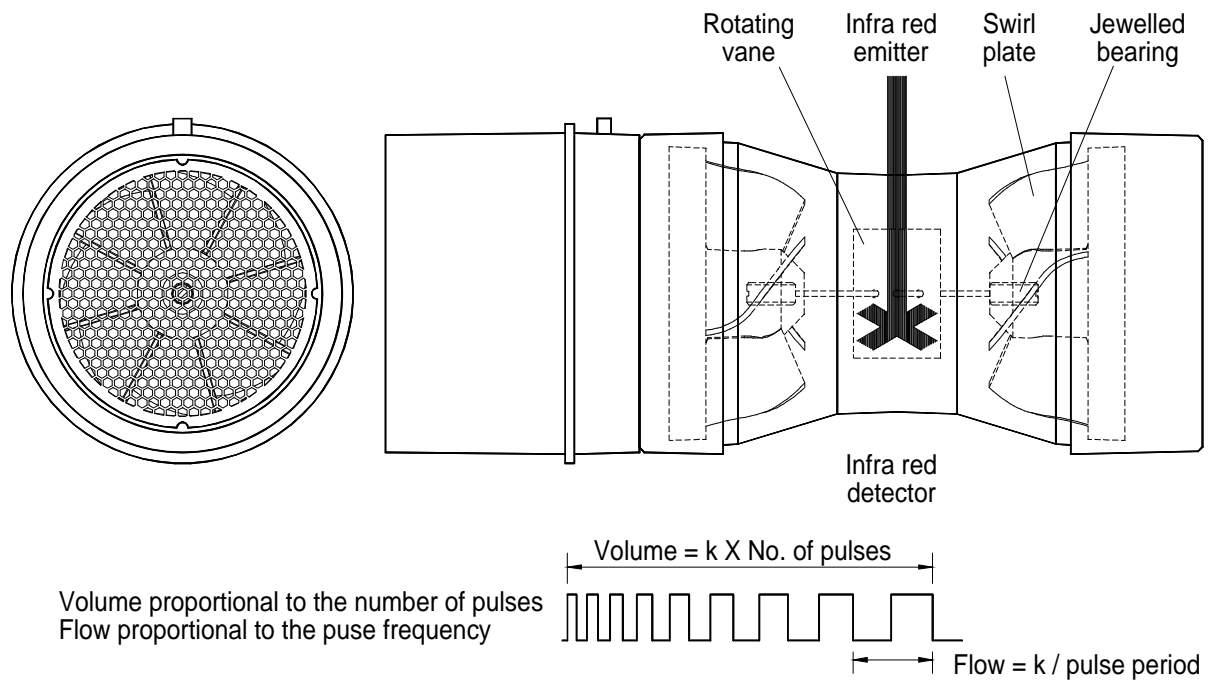

Disassembling the Microlab for Repairs

1. Disconnect all mains power supplies
2. Remove paper roll and paper roll housing cover, and put to one side
3. Remove the battery cover / screw and retain.

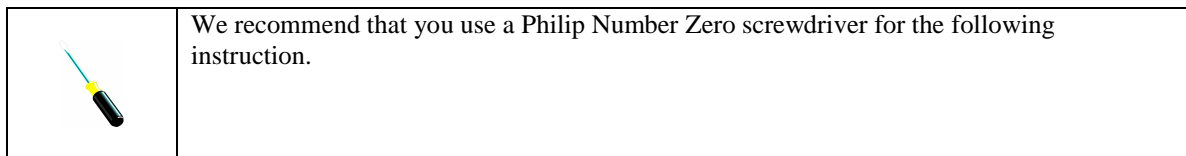

4. Place the Microlab face down to remove the four screws in the lower moulding, and put the screws to one side.
5. Turn the unit face up before easing the upper and lower mouldings apart.
6. Reconnect mains power supply
7. The Microlab is now ready for Fault Finding.

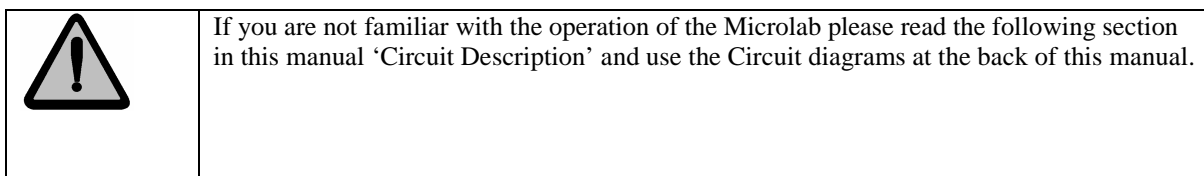

Reassembling the Microlab after Repairs

1. Disconnect the mains power supply
2. Position the top moulding over the bottom moulding and ensure that they mate up correctly. Also, ensure that the keypad, LCD display flexi connectors and battery are connected and correctly positioned.
3. Place the Microlab face down and insert the four screws into the lower moulding and secure to the top moulding. Replace the battery cover and screw fixing.
4. Turn the unit face up and connect to the mains supply.
5. Turn the unit on and offer up the printer paper roll as explained in the operating manual. Replace the paper cover.
6. The Microlab is now ready for operation.

Circuit Description

Overview (Drawing 050-01)

The microprocessor control circuit carries out the spirometry routines, monitors the transducer pulses and keypad, and drives the display under the control of the program stored in the battery backed RAM.

The power supply uses the mains adapter, internal Nickel-Cadmium (Ni-Cad) cells and an internal lithium backup as its sources of energy. The supply provides 5 volts to the control circuit, -12 volts supply for the display and RS232 driver circuit, 3 volts RAM backup, controls the charging current to the Ni-Cad battery pack, and provides for battery management.

The microprocessor (U1) communicates with the real time clock (U9), the output latch (U8), and the display under the control of the program, stored in the RAM (U7), using a multiplexed address and data bus decoded by a data latch (U2). The RAM, which is used both for program storage and for temporary data storage, has a memory map which is partitioned by the action of the PAL (U5) into writable and non-writable areas.

Processor Control Section (Drawing 050-02)

Address bus

The microprocessor (U1) uses a multiplexed address bus. The lower order address lines are latched into U2 with the address strobe (AS).

The program for the microprocessor (U1) is stored in a 128kByte, battery backed static ram, (U7). As the address space of the processor is limited to 64kBytes the ram address space is paged using a programmable array logic device (U5). This device decodes address lines A1, A13, A14, A15, port lines PD5, PA4, control line R/W, clock signal E, mode control lines MODA, MODB, and the external reset line to provide the following outputs:

RAM address lines A15 and A16

Chip select lines (CS) for the display and latch (U8)

Write enable (WR) for display, latch, and RAM

Read enable (RD) for the display

Output enable (OE) for the RAM

Reset

The reset circuit consists of a single chip reset (U3) which holds the reset line (RES) low for 350ms after the 5 volt supply has reached the threshold voltage of 4.5 volts. The reset signal is applied to the microprocessor (U1), display, programmable array logic device (U5), and the printer driver processor (U18).

Keypad

The keypad consists of a matrix of 14 keys (ON/OFF, 0 to 9, DELETE, and ENTER) together with a separate paper feed key (PAPER). The matrix is read by successively asserting (5 volts) the columns of the matrix and reading the state of the rows to determine which key has been pressed. The microprocessor asserts the columns by writing to the latch (U8) and reads the rows directly on port E (PE4 to PE7). The diode (D10) prevents current flowing from an asserted line of the latch to one at 0 volts in case of two keys on the same row being depressed simultaneously. The resistors (R36 to R39) biases the PE4 to PE7 to 0 volts.

Real Time Clock

The real time clock (U9) is set by the processor during the factory set-up and should not require any further adjustment. The processor communicates with the real time clock (RTC) with a serial interface line to pin 5 of the RTC. The RTC is selected by the signal from pin 12 of the output latch (U8).

Display

The display is a custom graphic 128 by 64 dot LCD with in-built control circuitry. The contrast is adjusted by varying the voltage on pin 3 between -4 and -12 volts with VR1. This potentiometer varies the output of the voltage inverter, U12.

Serial interface

The microprocessor communicates with the integral printer and the external RS232 port using its serial communications interface. Serial information from the microprocessor is switched to either the printer driver or the external RS232 port under the control of the signal appearing on pin 9 of the latch (IC5). This signal controls the switching logic of IC10 and IC8. The serial output from the microprocessor, TXD, is applied to the input of IC10. Depending upon the state of the control signal, the serial information will either pass through IC10 to the printer controller (IC17), or through the level converter (TR4, and R22) to the external RS232 port.

Battery monitoring

The microprocessor contains eight, 8 bit analogue to digital converters. One of these, AN3 is used to monitor the condition of the main supply (BAT1). The main supply is monitored at the input to the logic 5 volt regulator (IC11) and the user will be alerted to a low battery condition when the voltage falls below 6 volts. The voltage is divided by two with R8 and R9 to bring the voltage within the range of the A/D converter (5 volts). AN3 also detects when the external power supply has been applied. One end of R10 is pulled to 0 volts when the external supply is not applied and the voltage read on the A/D converter will be up to 4 volts for a fully charged battery. With the external supply applied, the voltage will rise above 5 volts.

Printer Driver (Drawing 050-04)

The printer driver uses a single chip micro-controller (U18) with on board program memory and RAM to receive serial data from the microprocessor (U1) and control the printer mechanism. The printer mechanism uses stepper motors to drive the print head and paper feed. Each stepper motor uses four lines, driven sequentially. The order of in which the lines are driven determines the direction of rotation. The thermal print head uses eight heater elements. The stepper motors and print head signals are generated on port A and B (active high) of the micro-controller (U18). The signals pass through two octal high current Darlington drivers (U16 and U17). Timing for Port A and B is derived from an adjustable oscillator comprising of U19, R11, R32 to R35, C19, D9 and VR2. Adjusting VR2 varies the oscillator frequency and consequently the period for which the thermal elements are energised. This in turn adjusts the print density. After the micro-controller is first reset, the print head is driven to the left until the end switch is activated. The end switch consists of a normally closed pair of contacts accessed at pins 1 and 2 of the printer connector, PL1. The end switch is detected by PD5 on the micro-controller.

Power Supply

External power input, 5 volt logic and –12 volt supply (Drawing 050-03)

The external power input is applied through J5. Power is applied to the Ni-Cad charging circuit and a 9 volt regulator (U14) through a reverse polarity protection diode, D5. The charging circuit consists of R20, R27, TR3, and D2. These components are in a constant-current configuration and supply a nominal 60mA to the Ni-Cad battery pack (BAT1). The charging indicator (LED1) is driven from the output of U14 through R28. BAT1 is isolated from the circuit during charging by the action of D6, which ensures that only the regulated output of IC7 can supply power when the external power supply is connected. Power is supplied to the circuit when SW1 is switched, turning on the series pass transistor TR5. TR5 can also be held on by the microprocessor through TR2 connected to PA5 of IC1. This feature is used by the program to ensure integrity of data during periods of writing to the RAM when the user may turn the unit off. The output of TR5 is filtered by R40 and C43 and used as an unregulated power supply for IC26, IC29 and, IC27. All logic circuitry has 5 volts supplied from a low drop-out regulator, IC11. The display requires a negative bias voltage and this is produced by the –12 volt generator (IC12, C5, C6, D10, C7, and D7). Display contrast is adjusted by varying the negative bias through the accessible VR1.

Printer mechanism supply

6 volts (VP) is supplied to the printer mechanism from the low drop-out, high current regulator, U20. The input to IC16 comes from the Ni-Cad battery pack or external power supply through SW1.

Transducer interface

The supply to the two series LEDs inside the transducer housing is provided through TR7. This is controlled by port pin PA3 of the processor and is only turned on during a spirometry manoeuvre to conserve power. However, power is supplied to the transducer through D7 continuously when the mains adapter is connected.

Inside the transducer housing the two phototransistors used to detect the interrupted infra-red beam are in open collector configuration. The collectors are connected to pins 2 and 3 of SK2. The pull up resistor for the phototransistor connected to pin 2 is provided by R18 and R21. The pull up resistor for the other phototransistor is provided by R19 and R20. The signals from the phototransistors are applied to the pulse timing input of the processor (pin 32) and a general purpose port pin 33 after being squared up by the action of the schmitt inverters IC8 A and B. The rising edge of the signal applied to pin 32 causes an interrupt to be generated in the processor. This interrupt is processed by incrementing a pulse count, timing the period since the last pulse and by reading the state of pin 33. The pulse count is used to determine the volume passed through the transducer since the start of the test and the pulse period is used to determine the flow at each volume increment. The state of pin 33 at the time of the interrupt determines the direction of flow.

Parts List

U1	MC68HC11E1CFN	MOTOROLA SM MICROCONTROLLER
U2	74HC573	SM OCTAL LATCH
U3	DS1233D-10	DALLAS ECONO RESET
U4	74HC14	SM HEX SCHMITT INVERTER
U5	PALCE16V8Z25PC	AMD ZERO POWER CMOS PLD DIP PACKAGE
U5(S)		20 PIN DIL SOCKET
U6	74HC32	SM QUAD TWO INPUT OR GATE
U7	KM681000BLG/BLG-L	SAMSUNG 1 MEG SM STATIC RAM 55-150ns ACCESS TIME
U8	74HC273	SM OCTAL D FLIP-FLOP
U9	PCF8583T	PHILIPS SM CLOCK CALENDER WITH 256 BYTE RAM
U10	BU4S11 OR BU4S01	RHOM INDIVIDUAL SM CMOS GATE
U11	LM2931M-5.0	LOW DROP OUT 5 VOLT 100mA SM REGULATOR
U12	LT1054CS8	SM VOLTAGE CONVERTOR
U13	4093	SM QUAD NAND GATE
U14	LM2940T-9.0	LOW DROP OUT 9 VOLT 1 AMP REGULATOR
U15		DENSITRON INVERTOR
U16	ULN2803LW	8 DARLINGTON SM ARRAY ALTERNATIVE TD62083AF
U17	ULN2803LW	8 DARLINGTON SM ARRAY ALTERNATIVE TD62083AF
U18	MC68HC705C9ACFN	MOTOROLA OTP SM MICROPROCESSOR
U19	4069UB	SM UNBUFFERED HEX INVERTOR
U20	LT1084CT	LOW DROP OUT ADJUSTABLE VOLTAGE 5 AMP REGULATOR
R1		1M SM RESISTOR 0.125 WATT 5% SIZE 0805
R2		1M SM RESISTOR 0.125 WATT 5% SIZE 0805
R3		1M SM RESISTOR 0.125 WATT 5% SIZE 0805
R4		100K SM RESISTOR 0.125 WATT 5% SIZE 0805
R5		100K SM RESISTOR 0.125 WATT 5% SIZE 0805
R6		100K SM RESISTOR 0.125 WATT 5% SIZE 0805
R7		100K SM RESISTOR 0.125 WATT 5% SIZE 0805
R8		100K SM RESISTOR 0.125 WATT 5% SIZE 0805
R9		100K SM RESISTOR 0.125 WATT 5% SIZE 0805
R10		100K SM RESISTOR 0.125 WATT 5% SIZE 0805
R11		100K SM RESISTOR 0.125 WATT 5% SIZE 0805
R12		100K SM RESISTOR 0.125 WATT 5% SIZE 0805
R13		10K SM RESISTOR 0.125 WATT 5% SIZE 0805
R14		10K SM RESISTOR 0.125 WATT 5% SIZE 0805
R15		3K9 SM RESISTOR 0.125 WATT 5% SIZE 0805
R16		8K2 SM RESISTOR 0.125 WATT 5% SIZE 0805
R17		8K2 SM RESISTOR 0.125 WATT 5% SIZE 0805
R18		1K SM RESISTOR 0.125 WATT 5% SIZE 0805
R19		1K SM RESISTOR 0.125 WATT 5% SIZE 0805
R20		1K SM RESISTOR 0.125 WATT 5% SIZE 0805
R21		1K SM RESISTOR 0.125 WATT 5% SIZE 0805
R22		1K SM RESISTOR 0.125 WATT 5% SIZE 0805
R23		1K SM RESISTOR 0.125 WATT 5% SIZE 0805
R24		1K SM RESISTOR 0.125 WATT 5% SIZE 0805
R25		330K SM RESISTOR 0.125 WATT 5% SIZE 0805
R26		33K SM RESISTOR 0.125 WATT 5% SIZE 0805
R27		10 OHM SM RESISTOR 0.125 WATT 5% SIZE 0805
R28		330 OHM SM RESISTOR 0.125 WATT 5% SIZE 0805
R29		1K SM RESISTOR 0.125 WATT 5% SIZE 0805
R30		120 OHM SM RESISTOR 0.125 WATT 5% SIZE 0805

R31		470 OHM SM RESISTOR 0.125 WATT 5% SIZE 0805
R32		2K2 SM RESISTOR 0.125 WATT 5% SIZE 0805
R33		22K SM RESISTOR 0.125 WATT 5% SIZE 0805
R34		22K SM RESISTOR 0.125 WATT 5% SIZE 0805
R35		150K SM RESISTOR 0.125 WATT 5% SIZE 0805
R36		10K SM RESISTOR 0.125 WATT 5% SIZE 0805
R37		10K SM RESISTOR 0.125 WATT 5% SIZE 0805
R38		10K SM RESISTOR 0.125 WATT 5% SIZE 0805
R39		10K SM RESISTOR 0.125 WATT 5% SIZE 0805
R40		10K SM RESISTOR 0.125 WATT 5% SIZE 0805
RN1		10 SIL COMMONED RESISTOR NETWORK
VR1	T18 S/I S/B S/T 20KA	PIHER 20K LINEAR POTENTIOMETER
VR2	3204X203P	MEC CITEC SINGLE TURN 20K SM PRESET
C1		33pF CERAMIC CAPACITOR SIZE 0805
C2		33pF CERAMIC CAPACITOR SIZE 0805
C3		33pF CERAMIC CAPACITOR SIZE 0805
C4		33pF CERAMIC CAPACITOR SIZE 0805
C5	660-590(F)	1nF PHILIPS CERAMIC CAPACITOR SIZE 0805
C6	660-590(F)	1nF PHILIPS CERAMIC CAPACITOR SIZE 0805
C7	660-620(F)	10nF PHILIPS CERAMIC CAPACITOR SIZE 0805
C8	660-620(F)	10nF PHILIPS CERAMIC CAPACITOR SIZE 0805
C9	556-180(F)	47uF/16V SM ELECTROLYTIC CAPACITOR
C10	556-180(F)	47uF/16V SM ELECTROLYTIC CAPACITOR
C11	556-180(F)	47uF/16V SM ELECTROLYTIC CAPACITOR
C12	556-180(F)	47uF/16V SM ELECTROLYTIC CAPACITOR
C13	556-180(F)	47uF/16V SM ELECTROLYTIC CAPACITOR
C14	556-180(F)	47uF/16V SM ELECTROLYTIC CAPACITOR
C15	556-180(F)	47uF/16V SM ELECTROLYTIC CAPACITOR
C16	556-269(F)	22uF/35V SM ELECTROLYTIC CAPACITOR
C17	644-160(F)	0.1uF PHILIPS CERAMIC CAPACITOR SIZE 0805
C18	644-160(F)	0.1uF PHILIPS CERAMIC CAPACITOR SIZE 0805
C19	718-555(F)	820pF PHILIPS CERAMIC CAPACITOR SIZE 0805
C20	556-180(F)	47uF/16V SM ELECTROLYTIC CAPACITOR
C21	556-180(F)	47uF/16V SM ELECTROLYTIC CAPACITOR
C22		15pF CERAMIC CAPACITOR SIZE 0805
C23	644-160(F)	0.1uF PHILIPS CERAMIC CAPACITOR SIZE 0805
C24	644-160(F)	0.1uF PHILIPS CERAMIC CAPACITOR SIZE 0805
C25	644-160(F)	0.1uF PHILIPS CERAMIC CAPACITOR SIZE 0805
C26	644-160(F)	0.1uF PHILIPS CERAMIC CAPACITOR SIZE 0805
C27	644-160(F)	0.1uF PHILIPS CERAMIC CAPACITOR SIZE 0805
C28	660-620(F)	10nF PHILIPS CERAMIC CAPACITOR SIZE 0805
C29	644-160(F)	0.1uF PHILIPS CERAMIC CAPACITOR SIZE 0805
C30	644-160(F)	0.1uF PHILIPS CERAMIC CAPACITOR SIZE 0805
C31	644-160(F)	0.1uF PHILIPS CERAMIC CAPACITOR SIZE 0805
C32	644-160(F)	0.1uF PHILIPS CERAMIC CAPACITOR SIZE 0805
C33	644-160(F)	0.1uF PHILIPS CERAMIC CAPACITOR SIZE 0805
TR1	DTA114EK	RHOM PNP DIGITAL TRANSISTOR SOT 23 PACKAGE
TR2	FMMT591	ZETEX PNP TRANSISTOR SOT 23 PACKAGE
TR3	2SB1189	RHOM PNP TRANSISTOR - MPT (SOT89) ALTERNATIVE 2SB1188
TR4	DTC114EK	RHOM NPN DIGITAL TRANSISTOR SOT 23 PACKAGE
TR5	DTC114EK	RHOM NPN DIGITAL TRANSISTOR SOT 23 PACKAGE
TR6	DTC114EK	RHOM NPN DIGITAL TRANSISTOR SOT 23 PACKAGE
TR7	DTB113EK	RHOM PNP DIGITAL TRANSISTOR SOT 23 PACKAGE

TR8	FMMT491	ZETEX PNP TRANSISTOR SOT 23 PACKAGE
TR9	FMMT491	ZETEX PNP TRANSISTOR SOT 23 PACKAGE
TR10	FMMT491	ZETEX PNP TRANSISTOR SOT 23 PACKAGE
LED	178-307 (F)	T1/3mm ORANGE LED
D1	IMN10	ROHM 3 DIODE ARRAY - IMD PACKAGE
D2	IMN10	ROHM 3 DIODE ARRAY - IMD PACKAGE
D3	S1ZAS4	SHINDENGEN 1.2A DUAL SCHOTTKY DIODE
D4	BAT43W	SCHOTTKY DIODE SOD123 PACKAGE (ALTERNATIVE BAT42W)
D5	S1NB20	SHINDENGEN 1A BRIDGE RECTIFIER
D6	DE5SC4M	SHINDENGEN 5A DUAL SCHOTTKY DIODE
D7	1SR154-400	RHOM 1A DIODE - PSM PACKAGE. ALTERNATIVE SHINDENGEN D1
D8	BAS19	SMALL SIGNAL DIODE SOT23 PACKAGE
D9	BAS19	SMALL SIGNAL DIODE SOT23 PACKAGE
D10	IMN10	ROHM 3 DIODE ARRAY - IMD PACKAGE
D11	BAT43W	SCHOTTKY DIODE SOD123 PACKAGE (ALTERNATIVE BAT42W)
L1	NLC565050T-3R9K	TDK 3.9uH SM INDUCTOR
L2	NLC565050T-3R9K	TDK 3.9uH SM INDUCTOR
DISPLAY	LE3228B-DNG-6190 20-004-172	DENSITRON 128 X 64 GRAPHIC DISPLAY ARIES 4 INCH, 20 WAY, TYPE 172, FLAT PIN STAKED FLEX JUMPER
PRINTER	STP411B-320	SEIKO THERMAL PRINTER MECHANISM
J1	MDS4	4 WAY MINI DIN SOCKET
J2	95001-2661	MOLEX 6 WAY DATA SOCKET
J3		20 WAY RIGHT ANGLED PIN HEADER
J4		11 WAY RIGHT ANGLED PIN HEADER
J5	DGP-20-PBT	2mm DC POWER SOCKET FROM G.ENGLISH ELECTRONICS
SPKR	PKM35-4A0	MURATA PIEZO CERAMIC SOUNDER
X1	221-570 (F)	4.9152 MHz CRYSTAL CAN STYLE HC49/4H
X2	103-868 (F)	32.768 KHz WATCH CRYSTAL
X3	573-589 (F)	4 MHz CERAMIC RESONATOR
BAT	045-14	CR2450 3V LITHIUM 500mA-hr BATTERY WITH PCB MOUNTING PIN
BAT1	050-14	7.2 VOLT 600mA-Hr NI CAD BATTERY PACK

Technical Support

Great Britain and World Headquarters

Micro Medical Ltd

PO Box 6

Rochester

Kent ME1 2AZ

Telephone + 44 (0)1634 360044

Fax +44 (0)1634 360055

Web Site <http://www.micromedical.com.uk>

Email support@micromedical.com.uk

Contact Micro Medical Ltd for the local agent in your region or country for local service:

Fault Analysis

The following analysis is only a guideline and should be carried out in a logical sequence. If the fault is still apparent after the following suggestions then the unit should be fault found using the circuit descriptions and circuit diagrams provided.

When the unit is turned on there is no display present

- Rotate contrast thumb wheel anti-clockwise to see if screen darkens.
- Connect charger to see if screen darkens and charging light illuminates.

When the unit is turned on the display is dark purple

- Rotate contrast thumb wheel clockwise to see if screen colour becomes lighter and characters are displayed.
- Connect charger to see if screen characters appear.

FVC readings are low

- Remove Turbine from Transducer housing. Taking the Turbine, move it uniformly through the air and check that the vane is not sticking.

The unit does not record any blows

- Inspect Transducer housing connector for damage.
- Check that Transducer housing lead is properly connected to J2.
- Remove Turbine from Transducer housing. Taking the Turbine, move it uniformly through the air and check that the vane is not sticking.
- Blow into Transducer housing and move Transducer head cable around to check for breaks in the cable.

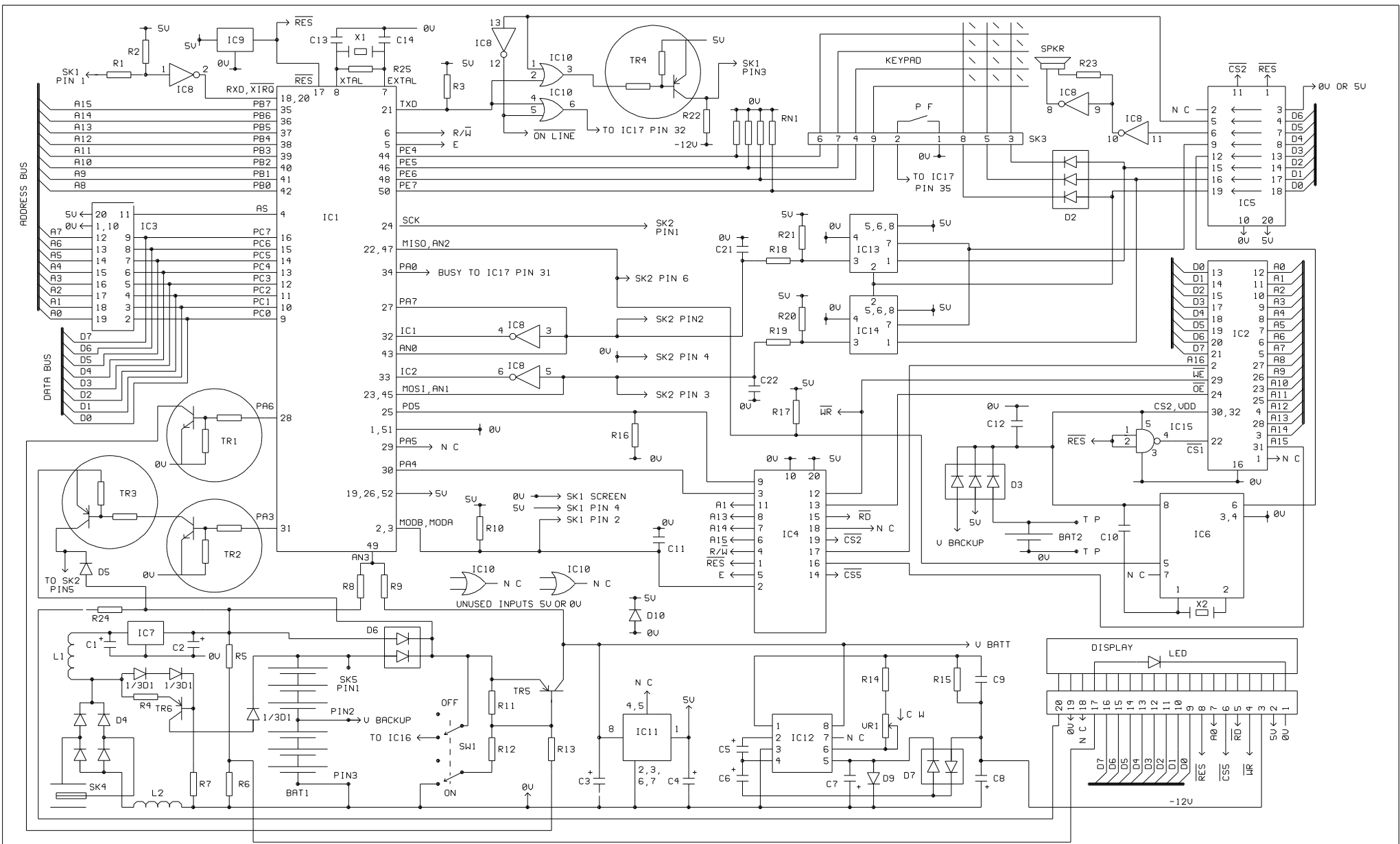

DRAWN	TITLE	ISSUE	DATE	DESCRIPTION OF MOD	DATE	DESCRIPTION OF MOD
C P L	ML3300 PROCESSOR SECTION					
DATE	DRAWING No 043-01	1 2				
1/12/97						

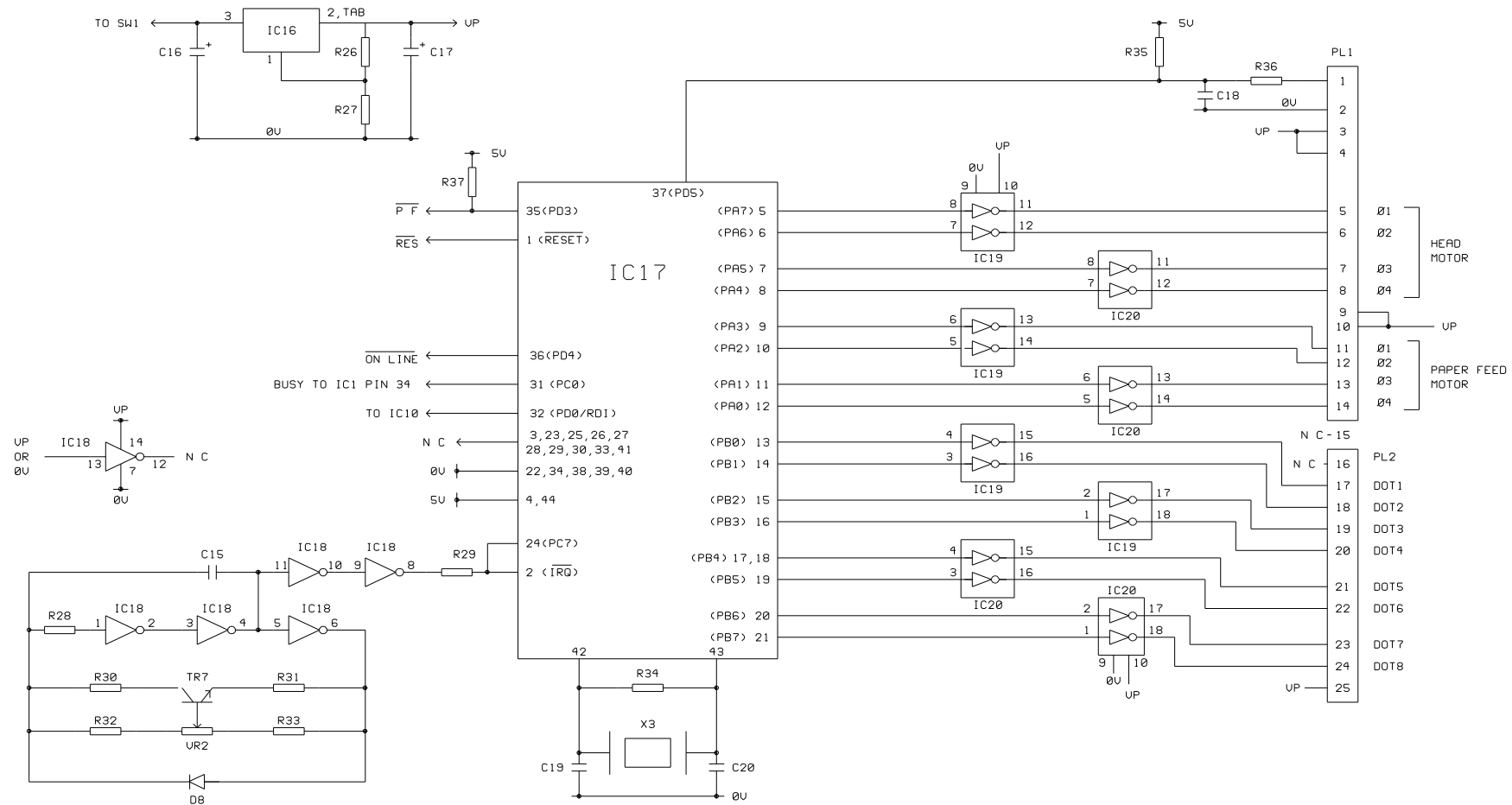

DRAWN C P L	TITLE ML3300 PRINTER DRIVER	ISSUE 1 1	DATE	DESCRIPTION OF MOD	DATE	DESCRIPTION OF MOD
DATE 3/4/97	DRAWING No 043-02					