

# LIFEPAK<sup>®</sup> 6

Portable Cardiac Care System

## Operating and Service Manual

Manual No. 800533-01 January 1979

**Physio-Control<sup>®</sup>**

11811 Willows Road  
Redmond, Washington 98052  
206/883-1181  
Cable: PHYSIO-RED, Telex: 32-0166

SERIAL NO. \_\_\_\_\_

LIFEPAK<sup>®</sup> and Physio-Control<sup>®</sup> are trademarks of the Physio-Control Corporation, 11811 Willows Road, Redmond, Washington 98052

## CHANGE SUMMARY

Due to continuing design update and addition of options available, the configuration of this instrument may change. This form will accompany any change pages impacted by a particular design change or update. This is a continuing historical form that will log all changes, with the date of these changes and the pages effected. Each individual change page will be dated at the bottom of the page, a page with no date is an original page. Check the change information section at the rear of this manual for any interim changes. For more detailed information concerning changes, contact your Service Representative or Physio-Control, Redmond, Washington.

CHANGE DATE	PAGES EFFECTED	REASON FOR CHANGE	EFFECTIVITY
<p>May 1978</p>	<p>Front page, 2-19, 3-7/3-8, 3-16/3-17, 3-26/3-27, 3-35/3-36, 3-38 thru 3-43, 3-47/3-48, 3-58/3-59, 4-1 thru 4-16, 4-18</p> <p>5-3 thru 5-64</p> <p>6-1 thru 6-24</p>	<p>Pages of text updated to reflect the latest configuration and functional changes (Sections II thru IV)</p> <p>Section V updated with new drawings and parts lists as applicable.</p> <p>Section VI updated and added engineering schematic drawings as applicable.</p>	
<p>Jan. 1979</p>	<p>Front page, i, ii, iii, 1-4 thru 1-7, 2-5, 2-8, 2-10, 2-12 2-21, 3-7 thru 3-9. 3-11, 3-12, 3-14, 3-15 thru 3-19, 3-21 3-24 thru 3-27, 3-35 thru 3-42, 3-44, 3-47, 3-48, 3-51 thru 3-53, 3-55, 3-57 thru 3-59, 3-61, 4-2 thru 4-5, 4-10 thru 4-16, 4-13, 4-19, 4-29, 4-41 (added pages 4-18A, 4-18B, 4-42 thru 4-46)</p> <p>5-2 thru 5-65</p>	<p>Pages of text updated to reflect the latest configuration and functional changes (Sections I thru IV).</p> <p>Section V updated assembly drawings and parts lists as applicable.</p>	

CHANGE SUMMARY  
(Continued)

CHANGE DATE	PAGES EFFECTED	REASON FOR CHANGE	EFFECTIVITY
Jan. 1979 (continued)	6-1 thru 6-33	Section VI updated schematics and added applicable test point waveforms and/or voltages.	



## TABLE OF CONTENTS

<u>SECTION</u>	<u>PAGE</u>
LIST OF ILLUSTRATIONS . . . . .	iii
LIST OF TABLES . . . . .	iv
I. INTRODUCTION . . . . .	1-1
1-1 Scope . . . . .	1-1
1-2 Physical Description . . . . .	1-1
1-3 General . . . . .	1-1
1-4 Cardioscope/Recorder Module . . . . .	1-3
1-5 DC Defibrillator Module . . . . .	1-3
1-6 Features and Functional Description . . . . .	1-3
1-7 Cardioscope/Recorder Module . . . . .	1-3
1-8 DC Defibrillator Module . . . . .	1-3
1-9 Synchronized Cardioversion . . . . .	1-8
II. OPERATION . . . . .	2-1
2-1 General . . . . .	2-1
2-2 Controls and Indicators . . . . .	2-1
2-3 Operating Instructions . . . . .	2-10
2-4 Module Connection . . . . .	2-10
2-5 Input Power, AC or DC Operation . . . . .	2-10
2-6 Cardioscope/Recorder Module . . . . .	2-11
2-7 DC Defibrillator Module . . . . .	2-12
2-8 Synchronized Cardioversion . . . . .	2-13
2-9 Operator Service . . . . .	2-14
2-10 Operational Checkout . . . . .	2-14
2-11 Recorder Paper Replacement . . . . .	2-19
2-12 Recorder Stylus Replacement and Adjustment . . . . .	2-19
III. CIRCUIT DESCRIPTION . . . . .	3-1
3-1 Introduction . . . . .	3-1
3-2 Functional Description . . . . .	3-1
3-3 Monitor Module Circuits . . . . .	3-1
3-4 Defibrillator Module Circuits . . . . .	3-3
3-5 Cardioscope/Recorder . . . . .	3-6
3-6 Preamplifier Board . . . . .	3-6
3-7 Rate Board Circuitry . . . . .	3-12
3-8 No-Fade Board Circuitry . . . . .	3-24
3-9 Recorder Board Circuitry . . . . .	3-34
3-10 Rate Display Board Circuitry . . . . .	3-34
3-11 Power Supply/Deflection Board Circuitry . . . . .	3-38
3-12 Monitor Charger Board Circuitry . . . . .	3-44
3-13 DC Defibrillator . . . . .	3-46
3-14 Main Board Circuitry . . . . .	3-46
3-15 Defibrillator Charger Board Circuitry . . . . .	3-57
3-16 Test Load Board . . . . .	3-61

## TABLE OF CONTENTS (continued)

<u>SECTION</u>		<u>PAGE</u>
IV.	MAINTENANCE . . . . .	4-1
	4-1 Introduction . . . . .	4-1
	4-2 General . . . . .	4-1
	4-3 Warranty . . . . .	4-1
	4-4 Test Equipment . . . . .	4-1
	4-5 Repair Techniques . . . . .	4-3
	4-6 Cleaning . . . . .	4-3
	4-7 Component Identification . . . . .	4-4
	4-8 Cardioscope/Recorder Module . . . . .	4-4
	4-9 Troubleshooting . . . . .	4-4
	4-10 Test and Calibration . . . . .	4-4
	4-23 Major Component Removal and Installation . .	4-19
	4-38 DC Defibrillator Module . . . . .	4-25
	4-39 Troubleshooting . . . . .	4-25
	4-40 Test and Calibration . . . . .	4-29
	4-51 Major Component Removal and Installation . .	4-37
	4-54 Battery Maintenance Guide . . . . .	4-41
V.	PARTS LISTS AND ASSEMBLY DRAWINGS . . . . .	5-1
	5-1 General . . . . .	5-1
	5-2 Parts Lists . . . . .	5-1
	5-3 Part Ordering . . . . .	5-1
VI.	SCHEMATICS . . . . .	6-1
	6-1 General . . . . .	6-1

## LIST OF ILLUSTRATIONS

<u>FIGURE</u>	<u>TITLE</u>	<u>PAGE</u>
1-1	LIFEPAK 6 . . . . .	1-2
1-2	Typical ECG Waveform . . . . .	1-8
2-1	Cardioscope/Recorder Controls and Indicators . . . . .	2-2
2-2	Cardioscope/Recorder Module Rear Panel . . . . .	2-5
2-3	DC Defibrillator Module Controls and Indicators . . . . .	2-6
2-4	Module Connection . . . . .	2-11
2-5	Recorder Paper Placement . . . . .	2-19
2-6	Stylus Replacement . . . . .	2-21
3-1	Block Diagram Cardioscope/Recorder . . . . .	3-2
3-2	Block Diagram DC Defibrillator . . . . .	3-4
3-3	Preamplifier Board Schematic . . . . .	3-7
3-4	Preamplifier Board, Block Diagram . . . . .	3-10
3-5	Rate Board, Block Diagram . . . . .	3-13
3-6	Rate Board Schematic . . . . .	3-16
3-7	Rate Count Timing . . . . .	3-20
3-8	Beat Period Sensing, Sampling and Weighted Average . . . . .	3-22
3-9	No-Fade Board Schematic . . . . .	3-26
3-10	Cardioscope (CRT) Display . . . . .	3-31
3-11	Recorder Board Schematic . . . . .	3-35
3-12	Display Board Schematic . . . . .	3-37
3-13	Power Supply/Deflection Board Schematic . . . . .	3-39
3-14	Monitor Charger Board Schematic . . . . .	3-45
3-15	Main Board Schematic . . . . .	3-47
3-16	On-Off Control . . . . .	3-49
3-17	Paddle Interlocks Path to Ground . . . . .	3-56
3-18	Defibrillator Charger Board Schematic . . . . .	3-58
3-19	Test Load Board Schematic . . . . .	3-62
4-1	Cardioscope/Recorder Module Component Identification . . . . .	4-9
4-2	Offset Check Setup . . . . .	4-13
4-3	Cardioscope/Recorder Major Component Removal . . . . .	4-20
4-4	DC Defibrillator Key Voltage Waveforms . . . . .	4-30
4-5	DC Defibrillator Module Component Identification . . . . .	4-32
4-6	DC Defibrillator Output Waveforms . . . . .	4-35
4-7	DC Defibrillator Major Component Removal . . . . .	4-39
4-8	Battery Voltage Profile . . . . .	4-46
	PARTS LISTS AND ASSEMBLY DRAWINGS (SECTION V)	
	SCHEMATIC DRAWINGS (SECTION VI)	

## LIST OF TABLES

<u>TABLE</u>	<u>TITLE</u>	<u>PAGE</u>
1-1	LIFEPAK 6 General Specifications . . . . .	1-4
2-1	Cardioscope/Recorder Module Controls and Indicators . . . . .	2-3
2-2	Cardioscope/Recorder Module Rear Panel . . . . .	2-5
2-3	DC Defibrillator Module Controls and Indicators . . . . .	2-7
2-4	Cardioscope/Recorder Module Operational Checkout . . . . .	2-15
2-5	DC Defibrillator Module Operational Checkout . . . . .	2-17
2-6	Cardioscope/Recorder and DC Defibrillator Operational Checkout . . . . .	2-18
4-1	Test Equipment . . . . .	4-2
4-2	Cardioscope/Recorder Troubleshooting Guide . . . . .	4-5
4-3	Power Supply Voltage Check . . . . .	4-11
4-4	Lead Select Verification Test . . . . .	4-17
4-5	DC Defibrillator Troubleshooting Guide . . . . .	4-26
4-6	Energy Select Tolerances . . . . .	4-33
5-1	Cardioscope/Recorder Parts List and Assembly Drawings . . . . .	5-2 5-2
5-2	DC Defibrillator Parts List and Assembly Drawings . . . . .	5-2 5-2
6-1	Schematic Drawings . . . . .	6-1

## SECTION I INTRODUCTION

### 1-1. SCOPE

The manual provides the operating and service procedures for the LIFEPAK 6 Cardioscope/Recorder and DC Defibrillator Modules manufactured by Physio-Control Corporation, Redmond, Washington.

The six sections of this manual provide introductory, functional descriptions and specifications; circuit descriptions; maintenance procedures; illustrated parts lists; and engineering schematics.

### 1-2. PHYSICAL DESCRIPTION

The following paragraphs provide a brief physical description of the Cardioscope/Recorder and DC Defibrillator modules.

Figure 1-1 shows the LIFEPAK 6 Cardioscope/Recorder Module and the DC Defibrillator Module. Table 1-1 lists the general specifications of LIFEPAK 6.

- 1-3. General. LIFEPAK 6 is a portable precision electronic cardiac care system for monitoring the ECG signal from the heart and for applying controlled monophasic defibrillating pulse to the heart or, in the synchronized mode, for performance of elective cardioversion by using the patient generated R-wave as a timing reference.

LIFEPAK 6 consists of two modules: a Cardioscope/Recorder Module and a DC Defibrillator Module. Each module is battery or line operated, and they may be operated independent of each other or as a unit. The internal batteries are charged when the modules are connected to the line power. Full battery charge is accomplished in 16 hours for depleted cells.

The cardioscope/recorder module is connected to the DC defibrillator module through a special slide connector. They may be separated by pressing the lock release button on the right side of the DC defibrillator module. When joined, the two modules provide a lightweight combination that provides use of the system on a crash cart or hand carried from one area to another.

#### CAUTION

- This instrument to be used by authorized personnel only.
- Operator should be thoroughly familiar with information covered in sections I and II of the service manual before using.
- The LIFEPAK 6 should not be used in the presence of flammable agents or anesthetics.
- Do not discharge with Paddles shorted together or in open air.
- Stay clear of patient when defibrillating.

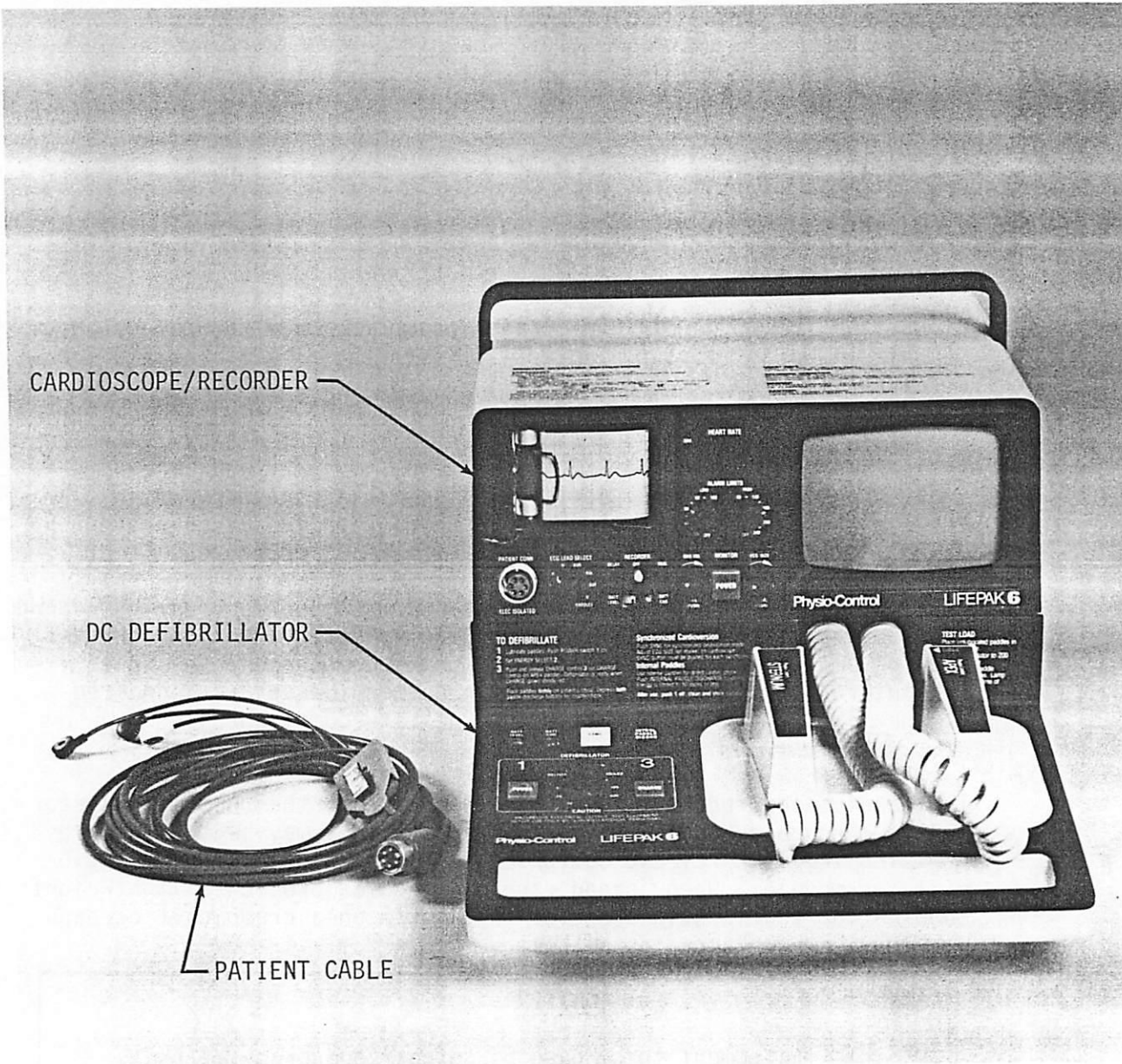

CARDIOSCOPE/RECORDER

DC DEFIBRILLATOR

PATIENT CABLE

Figure 1-1 LIFEPAK 6

1-3. General (Continued)

The circuitry used in the LIFEPAK 6 is solid state, temperature stable and highly reliable. The instrument is suitable for use in a hospital environment. Use in an explosive atmosphere is not recommended.

1-4. Cardioscope/Recorder Module. The cardioscope/recorder provides a continuous display through either a no-fade cardioscope for monitoring or through a recorder display allowing the user to obtain a hard copy of the information displayed on the cardioscope. The cardioscope/recorder module also provides for computing and displaying the heart rate from signals detected through Quik-Look paddles, internal paddles, or through externally applied electrodes and a 5-lead fully shielded cable.

1-5. DC Defibrillator Module. The DC defibrillator provides the means to deliver a controlled monophasic defibrillating pulse to the patient's heart with a delivered energy content of 5 to 400 joules (optional 500 joules). The pulse may be delivered with the paddles provided with the unit as well as with pediatric, anterior-posterior or through the limited delivered energy internal, spoon shaped paddles.

1-6. FEATURES AND FUNCTIONAL DESCRIPTION

The following paragraphs provide a functional description of the cardioscope/recorder and DC defibrillator modules.

1-7. Cardioscope/Recorder Module. All controls are clearly labelled and easily accessible. The location and function of all controls are described and illustrated in Section II. The patient generated ECG waveform is displayed on either the no-fade cardioscope or recorder which are driven by electrical networks designed for fast recovery from external overloading signals. The cardioscope trace sweeps at 25 mm/sec. The recorder provides real time diagnostic documentation at 25 mm/sec. By activating the Delayed Record switch on the monitor panel, the recorder documentation is delayed by about 4 seconds from real time. In effect, this provides the user with a 4 second memory and can be used for monitoring purposes. The circuitry is shielded to reject radio frequency interference.

When monitoring a patient's ECG wave-form through the patient cable, the input is completely protected from high voltage levels as may be obtained from the DC defibrillator. A systole beeper with adjustable volume control is provided for audible monitoring when the cardioscope or recorder cannot be watched.

The 3 digit heart rate monitor provides a continuous display of beats-per-minute (BPM) from 20 to 300 BPM. Adjustable low and high BPM limit alarm capabilities are provided. If the pre-set BPM limits are exceeded, an audio alarm system is triggered. The following additional features are included in the cardioscope/recorder unit: a one volt/millivolt and a one millivolt/millivolt in real time is available at the ECG OUT jack located on the back panel; a one millivolt calibration switch (CAL) is provided to calibrate the ECG gain; a low battery voltage level indicator; a momentary freeze switch for freezing the ECG signal on the cardioscope; and a battery charging indicator.

TABLE 1-1  
LIFEPAK 6 GENERAL SPECIFICATIONS

CHARACTERISTIC	*QUANTITY OR SPECIFICATIONS
<p>CARDIOSCOPE/RECORDER MODULE</p> <ul style="list-style-type: none"> <li>● SIZE (envelope)</li> <li>● WEIGHT</li> <li>● CARDIOSCOPE DISPLAY (CRT) Sweep Speed Bandwidth (-3dB)</li> <li>● COMMON MODE REJECTION</li> <li>● LOW BATTERY INDICATOR</li> <li>● CALIBRATION</li> <li>● RATE METER (Heart Rate)</li> <li>● ECG OUTPUT</li> <li>● INPUT</li> <li>● SYSTOLE BEEPER (QRS)</li> <li>● BATTERY CHARGING INDICATOR</li> </ul>	<p>10.75"x12"x4.5" (27.3x30.5x11.4cm)</p> <p>15 pounds (6.8 kg)</p> <p>3 inch x 4 inch (7.62cmx10.16cm) 25 mm/sec. + 1 mm 0.5 Hz to 30 Hz</p> <p>72 dB minimum with respect to isolated ground (with 5 K ohms misbalance at 60 Hz).</p> <p>Indicates approximate voltage level of battery.</p> <p>Internal 1 mV calibration (CAL), pushbutton switch to calibrate instrument.</p> <p>3 digit readout provides for display of the R-wave rate from 20 to 300 beats-per-minute (BPM). Adjustable high and low rate limit (audio) alarms.</p> <p>1 volt/millivolt and 1 millivolt/millivolt, 0.05 Hz to 100 Hz.</p> <p>Note: CSA units do not have this ECG OUTPUT function.</p> <p>1) Obtained through a 5 lead cable, or through QUIK-LOOK paddles.</p> <p>2) Selectable by rotary switch in any one of nine standard configurations (Paddles, I,II,III, AVR,AVL,AVF,V,STD).</p> <p>Adjustable Volume. ECG size control acts as threshold control.</p> <p>Illuminates when the battery is charging. Full battery charge is accomplished in 16 hours for depleted cells.</p>



TABLE 1-1 (Continued)  
LIFEPAK 6 GENERAL SPECIFICATIONS

CHARACTERISTIC	*QUANTITY OR SPECIFICATIONS
<p>CARDIOSCOPE/RECORDER MODULE</p> <ul style="list-style-type: none"> <li>● POWER SOURCE               <ul style="list-style-type: none"> <li>Battery</li> <li>Capacity</li> </ul> </li> <li>AC Input Power</li> <li>Power Consumption</li> <li>● RECORDER DISPLAY               <ul style="list-style-type: none"> <li>Sweep Speed</li> <li>Bandwidth (3 dB)</li> </ul> </li> <li>● FREEZE SWITCH</li> </ul>	<p>Nickel Cadmium Battery, 14.4V 1.5AH Cardioscope Monitoring, 2.5 hours min. at -10°C. Recorder Monitoring, 1 hour min. at 25°C.</p> <p>115 + 12 VAC, 60 Hz (or optional 230 VAC, 50 Hz).</p> <p>12 watts during cardioscope monitoring. 30 watts during recording with heat set to maximums.</p> <p>Paper Size 48 mm x 30 m (100 ft.) 25 mm/sec (fixed) 0.05 to 100 Hz (Real) 0.5 to 40 Hz (Delayed)</p> <p>Momentary pushbutton switch for freezing QRS complex observed on CRT.</p>
<p>DEFIBRILLATOR MODULE</p> <ul style="list-style-type: none"> <li>● SIZE (envelope)</li> <li>● WEIGHT</li> <li>● WAVEFORM</li> <li>● OUTPUT ENERGIES (Delivered)</li> <li>● CHARGE TIME</li> <li>● LOW BATTERY INDICATOR</li> <li>● OUTPUT PADDLES               <ul style="list-style-type: none"> <li>Electrode Size</li> <li>Cord Length</li> </ul> </li> </ul>	<p>19.25x12x4.5 inches (48.9x30.5x11.4 cm)</p> <p>19.25 pounds (8.6 kg)</p> <p>Monophasic Pulse, 5 milliseconds (Edmark)</p> <p>5,10,20,30,50,100,2-0,300,400 joules (Optional 500 joules). Internal paddles: 5,10,20,30,50 joules (Higher energies cannot be charged or delivered).</p> <p>To 400 joules in less than 10 seconds. (Optional) to 500 joules in 12.5 seconds.</p> <p>Indicates approximate voltage level of battery.</p> <p>82 cm<sup>2</sup> Extended Length 10 feet.</p>

TABLE 1-1 (Continued)  
LIFEPAK 6 GENERAL SPECIFICATIONS

CHARACTERISTIC	*QUANTITY OR SPECIFICATIONS
<p>DEFIBRILLATOR MODULE</p> <ul style="list-style-type: none"> <li>● BATTERY CHARGING INDICATOR</li>   <li>● POWER SOURCE <ul style="list-style-type: none"> <li>Battery</li> <li>Capacity</li>   <li>AC Input Power</li>   <li>Power Consumption</li> </ul> </li>   <li>● CHARGE CONTROLS</li>   <li>● ISOLATED OUTPUT</li>   <li>● DISCHARGE CONTROL</li>   <li>● DEFIBRILLATOR SYNCHRONIZER <ul style="list-style-type: none"> <li>Synchronized defibrillating pulse for elective cardioversion timed to occur on the first patient-generated R-wave which follows defibrillate command.</li>   <li>Sync Indicator</li>   <li>Sensitivity Control</li> </ul> </li> </ul>	<p>Illuminates when battery is charging. Full battery charge is accomplished in 16 hours for depleted cells.</p> <p>Nickel Cadmium Battery, 12V 1 AH Using battery pak, 25-400 joule discharges minimum at 25°C. 15-400 joule discharges minimum at -10°C.</p> <p>115 + 12 VAC, 60 Hz (or optional 230 VAC, 50 Hz)</p> <p>25 watts when power on. 250 watts during defib charge.</p> <p>Nine position rotary switch for presetting the desired discharge energy. Pushbutton on front panel initiates automatic charging to preset level. Paddle mounted pushbutton (on APEX paddle initiates automatic charging to preset level).</p> <p>Defibrillator output electrically isolated.</p> <p>Pushbutton discharge controls on both paddles in series to prevent accidental discharge. Pushbutton on control panel for use only on internal paddles.</p> <p>Marker on CRT trace identifies sync trigger point. The SYNC pushbutton switch will flash in systole to indicate synchronization.</p> <p>ECG size control acts as threshold control.</p>

TABLE 1-1 (Continued)

## LIFEPAK 6 GENERAL SPECIFICATIONS

CHARACTERISTIC	*QUANTITY OR SPECIFICATIONS
DEFIBRILLATOR MODULE ● DEFIBRILLATOR SYNCHRONIZER (Cont'd.) Sync-Defib Mode Control	Pushbutton switch can be depressed to change mode instantly from Sync to Defib or Defib to Sync.
GENERAL Line Cord Switches	Each Module is provided with ten foot special low leakage, low capacitance cable with special hospital duty, 3 prong connector.  Separate ON-OFF switches are provided for monitor and defibrillator modules.
<b>ENVIRONMENTAL CONDITIONS</b>	
Unless otherwise stated the performance requirements of LIFEPAK 6 shall be met under the following storage and operating conditions.	
<ul style="list-style-type: none"> <li>● ATMOSPHERIC PRESSURE</li> <li>● RELATIVE HUMIDITY</li> <li>● VIBRATION</li> <li>● SHOCK (capable of meeting operating requirements after shock).</li> <li>● DROP TEST (without resulting in operator or patient hazard during drop).</li> <li>● PADDLE DROP TEST (capable of meeting operational and safety requirements).</li> <li>● TEMPERATURE RANGE</li> </ul>	400 mm Hg to 772 mm Hg  0 to 95% (non-condensing)  MIL-STD-810C, Method 514.2, Procedure VIII, Figure 514.2-6, Curve V.  30 g's, $11 \pm 1$ milliseconds, half-sine, 18 impact shocks (3 in each direction) along each of three mutually perpendicular axes.  1 1/2 foot drop (45.7 cm) on a concrete floor on each axis (6 drops).  1 Meter Benchmark (3.281 feet) per FDA-MDS-021-0001, fifth draft, paragraph 4.3.2.  0°C to 55°C Operating -30°C to +65°C Storage

\* Specifications subject to change without notice. Unless otherwise stated all specifications at 25°C.

- 1-8. DC Defibrillator Module. The location of all controls for the defibrillator are described and illustrated in Section II.

Features on the DC defibrillator include: a ready flasher indicating the state of charge of the charge storage capacitor; a low battery voltage level indicator; a test load indicator which will flash if 200 joules or greater is delivered to the test load; and a battery charging indicator. A charge storage capacitor is the source of the high voltage defibrillating pulse. On command, relays disconnect the capacitor from the charging circuitry and the resultant pulse is discharged through the chest of a patient, through the external Quik-Look paddles or through internal, spoon shaped paddles. The energy available from the DC defibrillator can be adjusted in nine discrete positions ranging from 5 to 400 joules delivered. The instrument is capable of being recharged to 400 joules in less than 10 seconds.

- 1-9 Synchronized Cardioversion. The function of this circuit is to provide a synchronized trigger pulse to the LIFEPAK 6. This trigger pulse causes delivery of the defibrillating pulse at a point 20 milliseconds after the marker pulse for converting atrial fibrillation, atrial flutter or other arrhythmias. As shown in Figure 1-2, by using the R-wave as the initiating signal, the defibrillating pulse is delivered at a time which avoids the vulnerable T-wave portion of the ECG cycle where electrical shock may cause ventricular fibrillation.

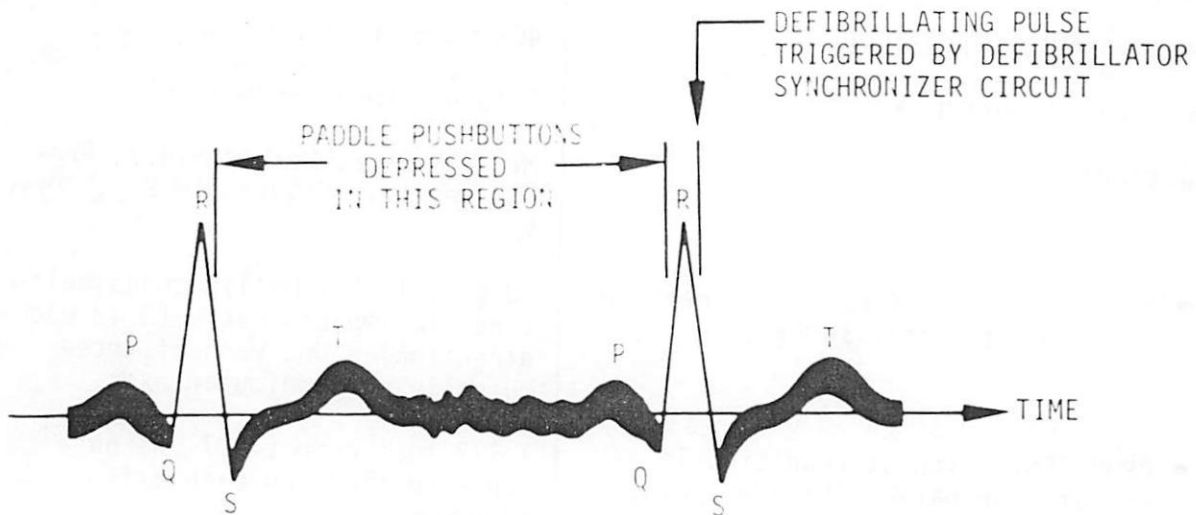

FIGURE 1-2 TYPICAL ECG WAVEFORM

## SECTION II OPERATION

### 2-1. GENERAL

This section provides information and procedures to properly operate and provides operator service for the LIFEPAK 6 Cardioscope/Recorder and DC Defibrillator Modules.

### 2-2. CONTROLS AND INDICATORS

The following paragraphs provide a brief description of the controls and indicators on LIFEPAK 6 Cardioscope/Recorder and DC Defibrillator.

- 1) The controls and indicators for the Cardioscope/Recorder Module are shown in Figure 2-1. Each control and indicator is keyed on the figure to the corresponding listing in Table 2-1. The table lists the control or indicator placarded nomenclature and briefly describes the functions of each control or indicator.
- 2) Figure 2-2 provides the rear panel view of the connections for external ECG recording. Each item is keyed on the figure to the corresponding listing in Table 2-2. The table lists the item placarded nomenclature and briefly describes the function.
- 3) The controls and indicators for the DC Defibrillator Module are shown in Figure 2-3. Each control and indicator is keyed on the figure to the corresponding listing in Table 2-3. The table lists the control or indicator placarded nomenclature and briefly describes the functions of each control or indicator.

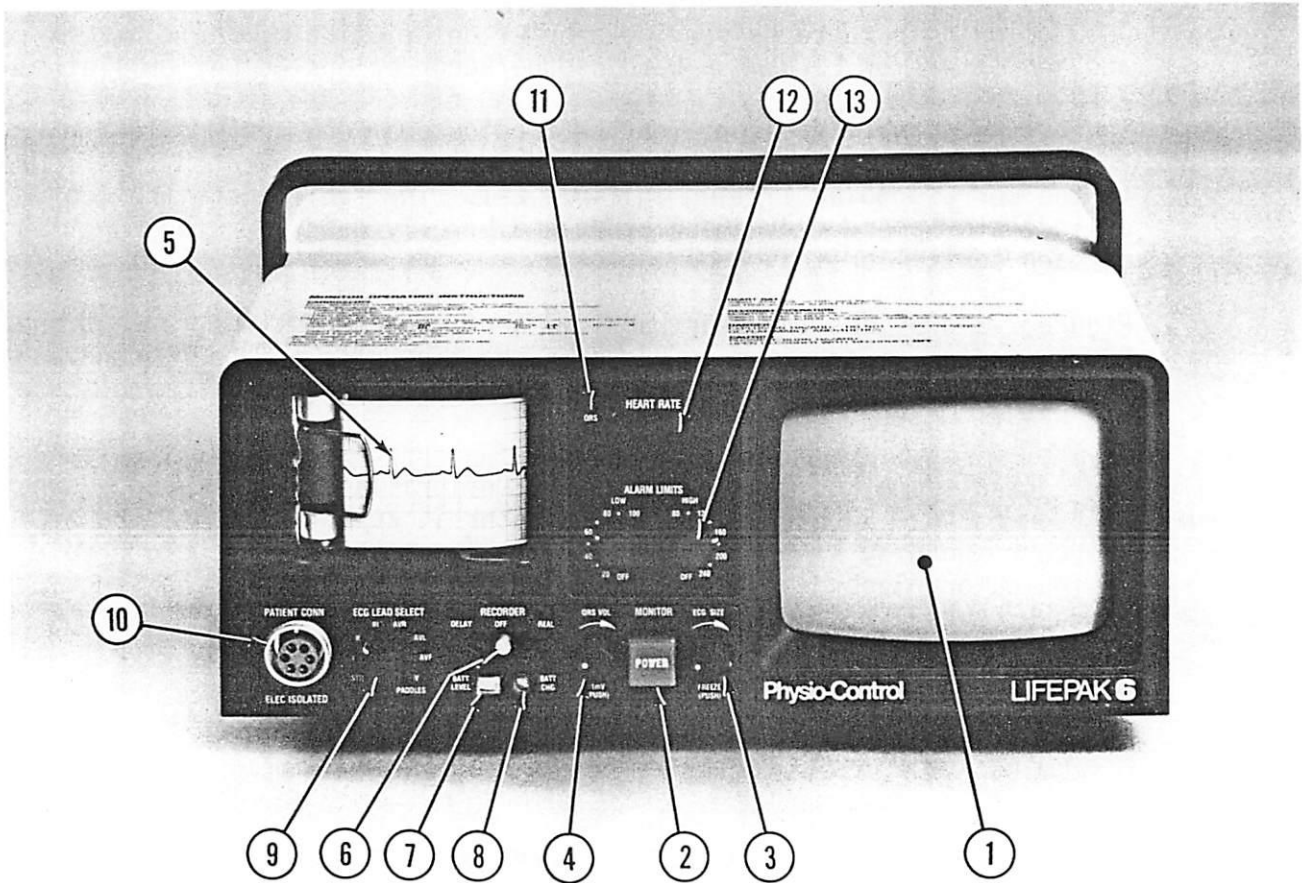

FIGURE 2-1 CARDIOSCOPE/RECORDER MODULE CONTROLS AND INDICATORS

TABLE 2-1

## CARDIOSCOPE/RECORDER MODULE CONTROLS AND INDICATORS

FIGURE KEY NO.	CONTROL OR INDICATOR	FUNCTION
1	CARDIOSCOPE	CRT display (no fade)
2	POWER	Pushbutton switch for applying power to instrument.
3	ECG SIZE	Used to adjust simultaneously the signal amplitude (vertical) fed to the cardioscope and recorder. Turn clockwise to increase amplitude.
	FREEZE	Depress knob to freeze trace on cardioscope. Release for current trace.
4	QRS VOL	Used to adjust sound volume of systole beeper.
	1 mv (Push)	Depress and release knob. Injects a positive going pulse strip corresponding to 1 mv when depressed. Convenient for presetting ECG SIZE in absence of input ECG.
5	RECORDER	Records ECG on standard heat sensitive paper.
6	DELAY/OFF/REAL	Toggle switch controls recorder ON/OFF. Switch to left turns recorder on: information recorded is four (4) seconds delayed. DELAY record is for routine monitoring. Switch to right turns recorder on; information is current (matches most current trace on cardioscope). Real record is of diagnostic quality and is used for diagnostic procedures such as 12 lead ECG and stress testing.
7	BATT LEVEL	(AC/DC Model Only) Battery Level indicator will indicate battery voltage continuously, however, the battery indicator should be observed when the AC power cord is disconnected from the wall outlet and with the POWER switch ON; marker in

TABLE 2-1 (Continued)

## CARDIOSCOPE/RECORDER MODULE CONTROLS AND INDICATORS

FIGURE KEY NO.	CONTROL OR INDICATOR	FUNCTION
7 (cont'd.)	BATT LEVEL (Continued)	green half indicates battery voltage adequacy, marker in red half indicates low battery. A depleted battery can be fully charged in 16 hours by connecting power cord to grounded wall outlet.
8	BATT CHG	(AC/DC Model Only) Indicator will illuminate when battery pak is charging.
9	ECG LEAD SELECT	Rotary switch for selecting desired paddles input or patient cable leads; STD, I, II, III, AVR, AVL, AVF and V.
10	PATIENT CONN	Connections for six (6) pin patient cable.
11	QRS	Indicator flashes when QRS sensed.
12	HEART RATE	Digital display of QRS rate from 20 to 300 beats-per-minutes (BPM). Heart rate updates every 3.5 seconds.
13	ALARM LIMITS	Switches for selecting HIGH and LOW heart rate limits. Violation of these preset limits will result in a continuous audio alarm. To silence alarm turn the control knobs to OFF.



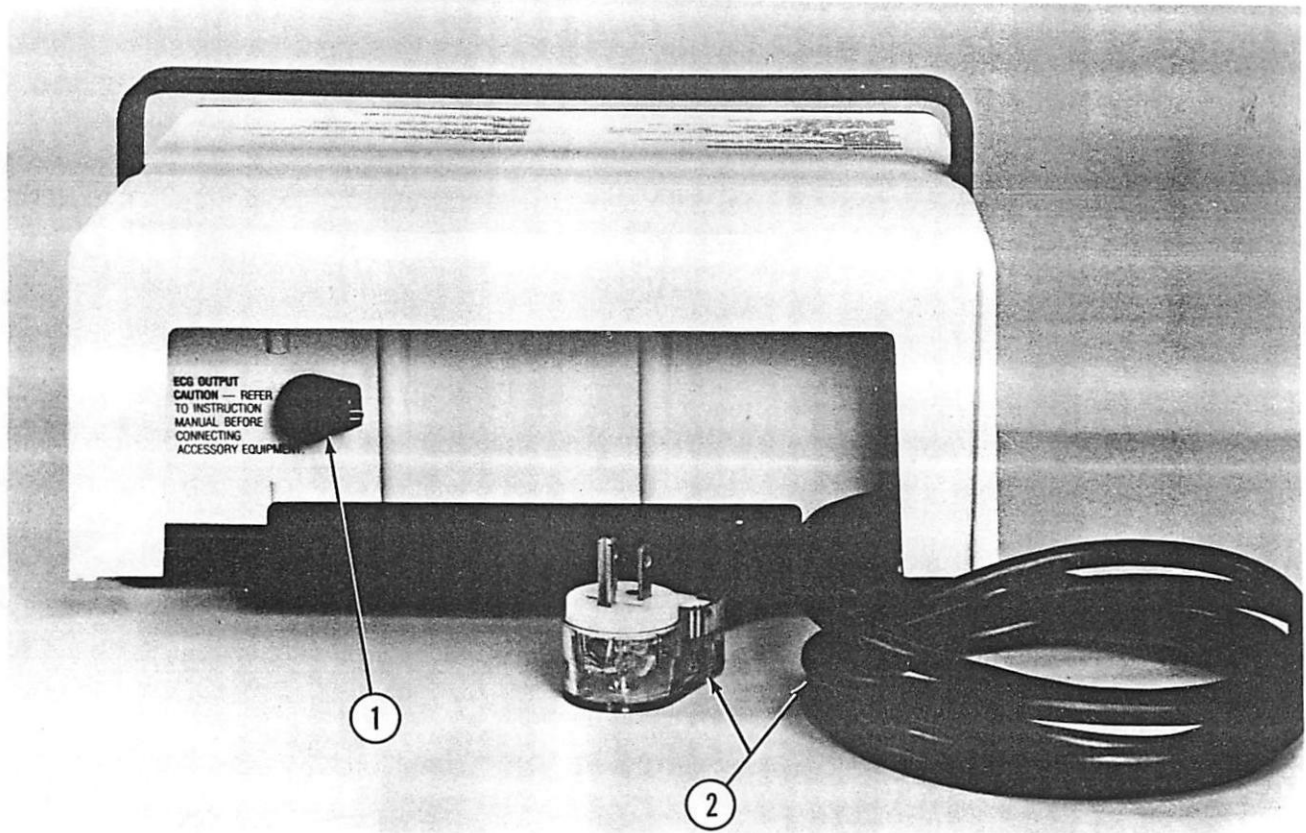

Figure 2-2 CARDIOSCOPE/RECORDER MODULE REAR PANEL

TABLE 2-2

CARDIOSCOPE/RECORDER MODULE REAR PANEL

FIGURE KEY NO.	CONTROL OR INDICATOR	FUNCTION
1	ECG OUTPUT *	ECG output jack for external monitoring equipment.
2	POWER CORD	Connect to wall receptable.

\*Note: CSA units do not have this ECG output function.

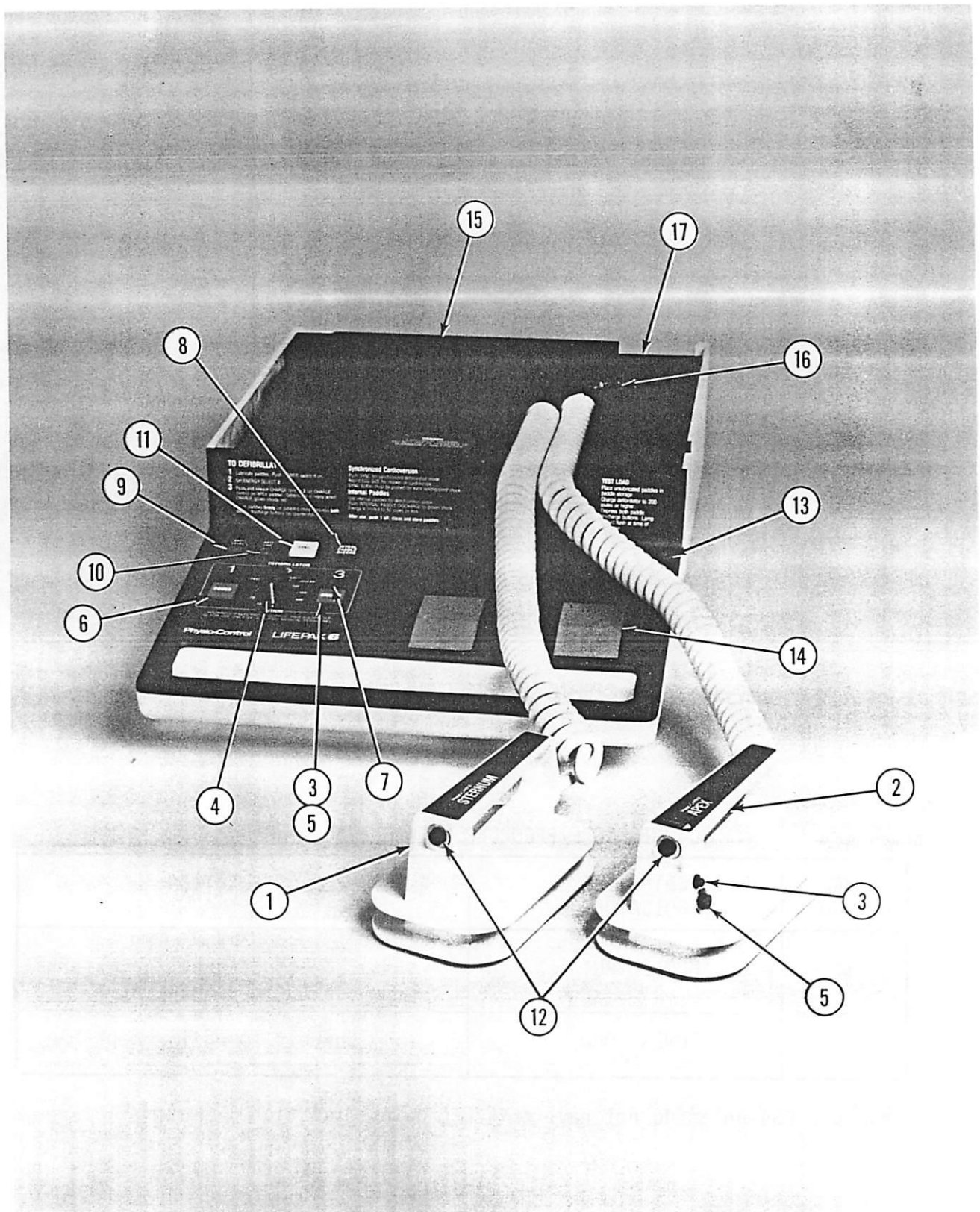

FIGURE 2-3 DC DEFIBRILLATOR MODULE CONTROLS AND INDICATORS

TABLE 2-3

## DC DEFIBRILLATOR MODULE CONTROLS AND INDICATORS

FIGURE KEY NO.	CONTROL OR INDICATOR	FUNCTION
1	STERNUM Paddle	Defibrillating electrode with discharge pushbutton.
2	APEX Paddle	Defibrillating electrode with a Discharge Pushbutton, a PUSH TO CHARGE Pushbutton, and a Charge Indicator.
3	Charge Indicator	Light flashes during charge cycle, steady light when ready, flashes again when instrument has bled down to approximately 90% of selected energy level.
4	ENERGY SELECT	Rotary switch with 9 discrete energy levels selectable; 5, 10, 20, 30, 50, 100, 200, 300, 400 joules delivered. (Optional 500 joules).
5	CHARGE Pushbutton	Momentary Pushbutton to charge defibrillator to preselected level. If ENERGY SELECT level is changed after instrument is charged, charge will be "dumped" and recharge is necessary.
6	POWER	Pushbutton switch. Indicator illuminates when power is on.
7	500J (Optional) Push w/CHARGE (Not shown)	Momentary Pushbutton to activate charging to 500 joules only.
8	INTRNL PADDLE DISCHG	Momentary pushbutton to discharge defibrillator when internal paddles are utilized.
9	BATT LEVEL	Battery Level indicator will indicate battery voltage continuously, however, the battery indicator should be observed when the AC power cord is disconnected from the wall outlet and with the POWER (1) switch ON; indicator

TABLE 2-3 (Continued)

## DC DEFIBRILLATOR MODULE CONTROLS AND INDICATORS

FIGURE KEY NO.	CONTROL OR INDICATOR	FUNCTION
9 (Cont'd)	BATT LEVEL (continued)	will indicate battery condition, marker in green half indicates battery voltage adequacy, marker in red half indicates low battery. A depleted battery can be fully charged in 16 hours by connecting AC power cord to grounded wall outlet.
10	BATT CHG	Indicator indicates battery is being charged.
11	SYNC	Momentary pushbutton switch to select synchronized mode. Button will illuminate and flash OFF with each QRS. To return to defibrillate (asynchronous) mode, depress button again. Defibrillator is automatically in defib mode when instrument is turned on and automatically returns to defib mode after discharge or if unit is disconnected from monitor.
12	Discharge Pushbutton	Discharge Pushbuttons on both paddles must be depressed simultaneously to discharge defibrillator. Energy will not be delivered unless the instrument is fully charged or "ready".
13	Test Load Indicator	Indicator flashes when 200 joules or greater is discharged into test load. Will not flash when less than 100 joules is delivered.
14	Test Load	50 ohm defibrillator test load. Metal contacts for receiving energy pulse from paddles.
15	Power Cord	Connect to wall receptacle
16	Paddle Connector	Connector for external or internal paddles.

TABLE 2-3 (Continued)

## DC DEFIBRILLATOR MODULE CONTROLS AND INDICATORS

FIGURE KEY NO.	CONTROL OR INDICATOR	FUNCTION
17	Power Receptacle for LP6 Monitor	Connector for connecting the Cardioscope/Recorder Module when both units are to be line- operated or charging the batteries from one power source.

## 2-3. OPERATING INSTRUCTIONS

The following paragraphs provide brief operating instructions for the LIFEPAK 6 cardiac care instrument. Observe the following cautions while operating the instrument.

### CAUTION

- This instrument is to be used by authorized personnel only.
- Operator should be thoroughly familiar with information covered in Sections I and II of this service manual before using.
- The LIFEPAK 6 should not be used in the presence of flammable agents to anesthetics.
- Do not discharge with paddles shorted together.
- Stay clear of patient when defibrillating.
- Do not discharge defibrillator into open air.
- Keep defibrillator paddles clean. Paddles covered with gel (wet or dry) present a hazardous electrical pathway between the paddle electrodes and the user during defibrillator discharge.
- Do not operate defibrillator in the presence of strong high energy electrical fields such as those generated by diathermy. If fibrillation occurs where diathermy is in use, turn off diathermy prior to turning on defibrillator.

- 2-4. Module Connection. The cardioscope/recorder module is connected to the DC defibrillator module through a special slide connector. They may be separated again by pressing the lock release button on the right side of the defibrillator. The slide connector makes both the mechanical and electrical connections between the two modules. Refer to Figure 2-4.

When the modules are separated, the electrical slide contacts are exposed. These exposed contacts do not represent a safety hazard and are used only to transfer the paddle pickup of the low level ECG signal from the DC defibrillator to the cardioscope/recorder or in the synchronized mode, the trigger pulse from the cardioscope/recorder to the DC defibrillator. No dangerous voltages are ever present at these contacts.

- 2-5. Input Power, AC or DC Operation.

- 1) For AC operating instrument, connect power cord to a three pin grounded power source. Do not use adapter.
- 2) To operate AC/DC instrument on AC input power, connect power cord to a three pin grounded power source. Do not use adapter. To operate AC/DC instrument on the internal battery, disconnect the power cord from the three pin grounded outlet. Turn POWER switch



Slide Connection



Release

Figure 2-4 Module Connection

2-5. Input Power, AC or DC Operation (Continued)

to ON and observe the BATT LEVEL indicator. Indicator should be in the "green" zone which indicates adequate battery voltage.

Note: When instrument is connected to the AC input power, the internal battery will charge (observe battery charging indicator on control panel). A depleted battery can be recharged in 16 hours.

2-6. Cardioscope/Recorder Module. The following paragraphs provide brief operating instructions for LIFEPAK 6 Cardioscope/Recorder Module. Refer to paragraph 2-10 for operator service which includes an operational checkout.

- 1) Connect patient cable into PATIENT CONN. If QUIK-LOOK paddles are to be used, the cardioscope/recorder and DC defibrillator must be connected together.
- 2) Attach either patient cable or paddles to patient.
- 3) Turn ECG LEAD SELECT switch to position desired.
- 4) Depress POWER pushbutton switch on.

CAUTION

When using the internal battery source, do not drain the battery completely; turn the instrument POWER switch off when not in use.

- 5) If recorder monitoring is desired, adjust the recorder DELAY/REAL switch to the position desired.

Note: When monitoring in the patient cable mode, during a defibrillation or elective cardioversion, the recording should be made in the DELAY switch position.

2-6. Cardioscope/Recorder Module (Continued)

- 6) Depress CAL momentary pushbutton switch, adjust ECG SIZE control for a 10 mm squarewave display on recorder or a convenient display on the cardioscope.
- 7) Adjust ECG SIZE control to obtain desired patient generated ECG display on cardioscope and/or recorder.
- 8) Adjust SYST VOL control to desired volume.  
Note: When volume is adjusted, "beeper" should coincide with each QRS complex.
- 9) If use of the ALARM LIMITS is desired, adjust the controls for proper HIGH and LOW limits.  
Note: Audible alarm is continuous when preset limits are exceeded. To turn off alarm, move the HIGH and/or LOW limit adjustments beyond the patient's rate.
- 10) If desired, connect external monitoring equipment to the ECG OUTPUT jack.

CAUTION

For patient safety do not connect accessory equipment to the ECG OUTPUT jack unless accessory equipment in combination with LIFEPAK 6 has been evaluated for fire and shock hazard.

- 11) Depress FREEZE switch on front panel; if the ECG signal on cardioscope is desired to be studied.  
Note: If FREEZE switch is depressed while recording in REAL mode, recording continues uninterrupted. If FREEZE switch is depressed while recording in DELAY mode, recording reverts to real-time until FREEZE is released. At that time, frozen information will be recorded and the unit then returns to DELAY mode.

2-7. DC Defibrillator Module. The following paragraphs provide brief operating instructions for LIFEPAK 6 DC Defibrillator. Monitoring using the paddles is discussed in paragraph 2-6. Refer to paragraph 2-10 for operator service including an operational checkout.

- 1) Press POWER 1 switch to on. Button will illuminate.  
Note: If operating on internal battery power, check BATT LEVEL indicator to insure adequate battery voltage.
- 2) Select desired energy to be delivered with ENERGY SELECT 2 switch.
- 3) Depress and release CHARGE 3 pushbutton switch either on defibrillator front panel or on APEX paddle.  
Note: If the (optional) 500 joules is to be delivered, the 500J PUSH w/CHG pushbutton switch must be pushed simultaneously with the CHARGE 3 pushbutton.

CAUTION

Indiscriminate use of energy settings above 400 joules may cause cardiac damage. Automatic selection of maximum energy is not recommended. (See Operators Instruction Manual).



2-7. DC Defibrillator Module (Continued)

- 4) Place paddles firmly on patient's chest.
- 5) DC defibrillator is ready to fire when red CHARGE indicator stops flashing and glows steady. DC defibrillator will not fire unless fully charged to preset level.

Note: Once the defibrillator has charged to the desired level and the charge indicator stops flashing, the instrument is ready to fire. If not fired, the charge will slowly bleed down. When the charge reaches 90% of the selected level, the CHARGE indicator will begin to flash and the instrument must be recharged before using.

If the ENERGY SELECT switch is inadvertently or intentionally changed while the defibrillator is charged, the charge is automatically dumped. It is necessary to recharge the instrument to defibrillate at a different setting.

CAUTION

Stay clear of patient when defibrillating.

- 6) Depress both paddle discharge pushbuttons simultaneously for counter-shock.
- 7) If repeat counter shock is necessary, depress CHARGE ③ pushbutton and repeat as above.
- 8) To dump charge and turn off defibrillator, depress POWER ① switch on defibrillator front panel. Button light will extinguish.
- 9) For internal defibrillation the external paddles are disconnected from the instrument (the LIFEPAK 6 cardioscope/recorder module must be separate from the defibrillator module to expose the paddle connector) and the connector for the internal paddles is then connected.
  - A. To defibrillate. Press POWER ① switch to on. Button will illuminate.
  - B. Select desired energy to be delivered with ENERGY SELECT ② switch. (Delivered energy is limited to 5, 10, 20, 30 and 50 joules with internal paddles).

Note: Instrument will not charge to nor deliver higher energies with internal paddles connected.
  - C. Depress and release CHARGE ③ pushbutton switch on front panel. Defibrillator is ready to fire when CHARGE indicator stops flashing and glows steady.
  - D. Depress INTRNL PADDLE DISCHG switch on front panel for countershock.
  - E. If repeat countershock is necessary, depress CHARGE ③ pushbutton and repeat as above.

2-8. Synchronized Cardioversion. The following paragraphs provide brief operating instructions for the LIFEPAK 6 synchronized cardioversion.

- 1) Connect the Cardioscope/Recorder and Defibrillator Modules together.

## 2-8. Synchronized Cardioversion (Continued)

- 2) Turn on POWER switch on both Cardioscope and Defibrillator Modules. Defibrillator will come on in manually triggered mode.
- 3) Connect patient to patient cable and set LEAD SELECT switch to lead II.

### CAUTION

Do not use defibrillator paddles as ECG pickup for elective cardioversions. Once the discharge push-buttons are depressed, artifact from poor contact or movement of paddles could cause synchronizer to fire defibrillator prematurely.

- 4) Press SYNC pushbutton switch on. Button will illuminate.
- 5) Adjust ECG SIZE control until marker blip occurs on ECG complex on cardioscope (CRT). SYNC pushbutton switch will flash and SYSTOLE sound will beep with marker. (It may be necessary to move the electrodes to get a signal with sufficient amplitude).
- 6) Set desired energy to be delivered with ENERGY SELECT (2) switch.
- 7) Depress and release CHARGE (3) pushbutton switch either on defibrillator front panel or on APEX paddle.
- 8) To discharge, depress both discharge buttons and hold until defibrillator fires on the next R-wave. Defibrillator will fire within 20 milliseconds of marker. Release.

After discharge, the defibrillator automatically returns to the defibrillate mode. If repeat synchronized cardioversion is required, place the defibrillator in the SYNC mode again by depressing the SYNC pushbutton switch on. When button is illuminated, synchronizer is on.

## 2-9. OPERATOR SERVICE

The following paragraphs provide operator service procedures including daily operational checkout, recorder paper replacement and recorder stylus adjustment and replacement.

- 2-10. Operational Checkout. Tables 2-4 and 2-5 provide operational checkout procedures for the cardioscope/recorder and DC defibrillator modules. Table 2-6 provides an operational checkout for Cardioscope/Recorder and DC Defibrillator modules connected together for verification of synchronized cardioversion.

These procedures will determine whether or not the LIFEPAK 6 Cardioscope/Recorder and DC Defibrillator modules function normally. These tests should be performed as routine maintenance. The operational checkout procedures are presented in tabular form to allow the using activity to copy them and use them as an ongoing preventative maintenance aid.

TABLE 2-4

## CARDIOSCOPE/RECORDER MODULE OPERATIONAL CHECKOUT

PROCEDURE	RESULTS
<ol style="list-style-type: none"> <li>1. Turn ALARM LIMITS to OFF position and SYS VOL control counterclockwise.</li> <li>2. Attach patient cable to PATIENT CONN connector.</li> <li>3. Recorder switch should be in off position.</li> <li>4. Set ECG LEAD SELECT switch to STD position.</li> </ol>	
<ol style="list-style-type: none"> <li>5. Push POWER button on.</li> </ol>	<p>Verify illuminous trace appears on cardioscope. (If AC/DC instrument, observe BATT level indicator for adequate battery voltage with power cord disconnected. With power cord connected to power source, verify that the Battery CHG indicator is illuminated.)</p>
<ol style="list-style-type: none"> <li>6. Depress 1 mV (PUSH) momentary pushbutton switch.</li> </ol>	<p>Squarewave pulse should appear on cardioscope. Adjust ECG size if necessary.</p>
<ol style="list-style-type: none"> <li>7. Set Recorder switch to REAL.</li> </ol>	<p>Verify recorder starts. If paper replacement is required, refer to paragraph 2-12.</p>
<ol style="list-style-type: none"> <li>8. Depress 1 mV (PUSH) momentary pushbutton switch.</li> </ol>	<p>A) Verify that a satisfactory display (pulse) is obtained on recorder.</p> <p>B) Adjust SYS VOL so that beep is heard with each 1mV signal.</p>
<ol style="list-style-type: none"> <li>9. Adjust low ALARM LIMITS from off position.</li> </ol>	<p>Verify that the audio alarm is activated.</p>
<ol style="list-style-type: none"> <li>10. Set ECG LEAD SELECT switch to position 1.</li> </ol>	<p>A) Verify interference is present on cardioscope trace with 4 or 5 lead cable. Place snap ends of white lead and black lead wires together-trace on cardioscope should stabilize.</p>

TABLE 2-4 (CONTINUED)

CARDIOSCOPE/RECORDER MODULE OPERATIONAL CHECKOUT

PROCEDURE	RESULTS
<p>10. (Continued)</p> <p>11. Return ECG LEAD SELECT switch to STD.</p> <p>12. Turn Recorder DELAY/REAL switch to DELAY.</p> <p>13. Set Recorder switch to OFF.</p> <p>14. Press POWER switch off.</p>	<p>B) Repeat A above with ECG LEAD SELECT switch to position II. Place snap ends of white lead and red lead wire together - trace on cardioscope should stabilize.</p> <p>C) Repeat A above with ECG LEAD SELECT switch to position III. Place snap ends of black lead and red lead wire together - trace on cardioscope should stabilize.</p> <p>Verify recorder starts and trace appears within one and 1/2 second. Depress 1mV (PUSH) pushbutton switch several times and verify that the squarewave pulse appears on cardioscope and is recorded on the ECG paper within 5 seconds.</p>

TABLE 2-5

## DC DEFIBRILLATOR MODULE OPERATIONAL CHECKOUT

PROCEDURE	RESULT
<p>Note: Do not lubricate paddles. Use firm contact at time of discharge on test load plates to prevent arcing, pitting of paddles, and to insure delivery of energies.</p>	
<p>1. Verify unlubricated paddles are firmly seated in storage area.</p>	
<p>2. Push POWER ① switch to on.</p>	<p>Verify that button indicator illuminates. (If AC/DC instrument, observe BATT level indicator for adequate battery capacity with power cord disconnected. With power cord connected to power source, verify that the battery CHG indicator is illuminated.)</p>
<p>3. Set ENERGY SELECT ② rotary switch to maximum energy.</p>	
<p>4. Depress CHARGE ③ push-button switch.</p>	<p>Verify indicator on panel flashes until fully charged and then indicator is on steady. Verify CHARGE indicator on APEX paddles also flashes until fully charged.</p>
<p>5. With unlubricated paddles firmly on test load plates in storage area. Depress both paddle DISCHARGE buttons simultaneously.</p>	<p>Verify charging time is less than 10 seconds.</p>
	<p>Verify TEST Load Indicator flashes with discharge.</p> <p>Note: Because of heat created at time of discharge into test load, do not repeat testing of defibrillator more than ten 400 joules discharges every hour at room temperature.</p>

TABLE 2-6

CARDIOSCOPE/RECORDER AND DC DEFIBRILLATOR OPERATIONAL CHECKOUT

PROCEDURE	RESULTS
<p>Note: The Cardioscope/Recorder and DC Defibrillator modules must be connected together for the following operational checkout.</p>	
<p>1. Push POWER switch, on cardioscope/recorder module, to on.</p>	
<p>2. Set ECG LEAD SELECT switch to PADDLES.</p>	<p>A. Verify that by touching one paddle face, the cardioscope trace shows interference.</p> <p>B. Repeat A above with the other paddle face.</p> <p>C. Place paddle faces together. Verify that the interference trace on cardioscope disappears.</p>
<p>3. Connect patient cable to ECG simulator and to PATIENT CABLE connector on cardioscope/recorder module.</p>	<p>Observe cardioscope for ECG signal.</p>
<p>4. Push POWER switch, on DC defibrillator, to on.</p>	<p>Verify PWR button indicator on DC defibrillator front panel illuminates.</p>
<p>5. Depress SYNC pushbutton switch.</p>	<p>Verify that the marker blip appears on R-wave (cardioscope) and SYNC indicator is illuminated</p>
<p>6. Set ENERGY SELECT switch to 200 joules or above.</p>	
<p>7. With paddles firmly on test load plates in storage area, depress both paddle DISCHARGE buttons simultaneously.</p>	<p>A. Verify defibrillator discharges on the next R-wave and that the test load indicator flashes.</p> <p>B. Following energy discharge, verify that the instrument returns to defibrillate mode.</p>



Figure 2-5 Recorder Paper Replacement

2-11. Recorder Paper Replacement. Refer to Figure 2-5 and proceed as follows.

- 1) Pull out paper carrier.
- 2) Remove old paper roll.
- 3) Replace with new paper roll. Note that the recorder paper must come off the roll in a counterclockwise direction.
- 4) Pull out short length of paper and close paper carrier.
- 5) Press POWER pushbutton switch to on. Set Recorder switch to DELAY position and ECG LEAD SELECT switch to STD position. While recorder is running, guide paper over all metal rollers and under rubber roller. Paper will be pulled through by rubber roller.

2-12. Recorder Stylus Replacement and Adjustment. Refer to Figure 2-6 and proceed as follows:

Note: The special stylus replacement tool (part of the replacement kit) will be required in the following procedure. For more detailed information, refer to instruction sheet accompanying replacement stylus.

2-12. Recorder Stylus Replacement and Adjustment. (Continued)

- 1) Press POWER switch off.
- 2) Lift out paper carrier and remove paper load to expose base of stylus.
- 3) Using the stylus replacement tool, loosen the two outside allen-head screws at base of stylus and turn counterclockwise until loose. Remove stylus with fingers.
- 4) Insert new stylus and tighten the two outside allen-head screws with insertion tool.
- 5) Replace paper load on paper carrier. Close paper carrier carefully and insure stylus moves out of the way of the writing edge and comes in contact with the paper when paper load carrier is shut. If the stylus does not touch the paper, lift the paper load carrier and adjust the middle stylus tension screw clockwise to increase pressure.
- 6) Adjust Stylus Heat control as necessary. Using the other end of the stylus replacement tool, adjust the stylus heat control potentiometer through the ring hole located under the paper carrier near the base of the stylus, for the desired line. A light line will provide longer stylus life.
- 7) Place ECG LEAD SELECTOR switch to STD (1mV) position. Set Recorder switch to REAL and let recorder run while depressing the 1 MV (PUSH) switch. Observe deflection and compare with below.

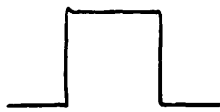

ACCEPTABLE  
(NOMINAL)



TOO LOOSE



TOO TIGHT

- 8) Adjust stylus tension screw if necessary. Repeat step 7 above.

Note: To insure AHA frequency response, adjust the stylus pressure to 4-6 grams using a gram gauge and check response to AHA specifications.



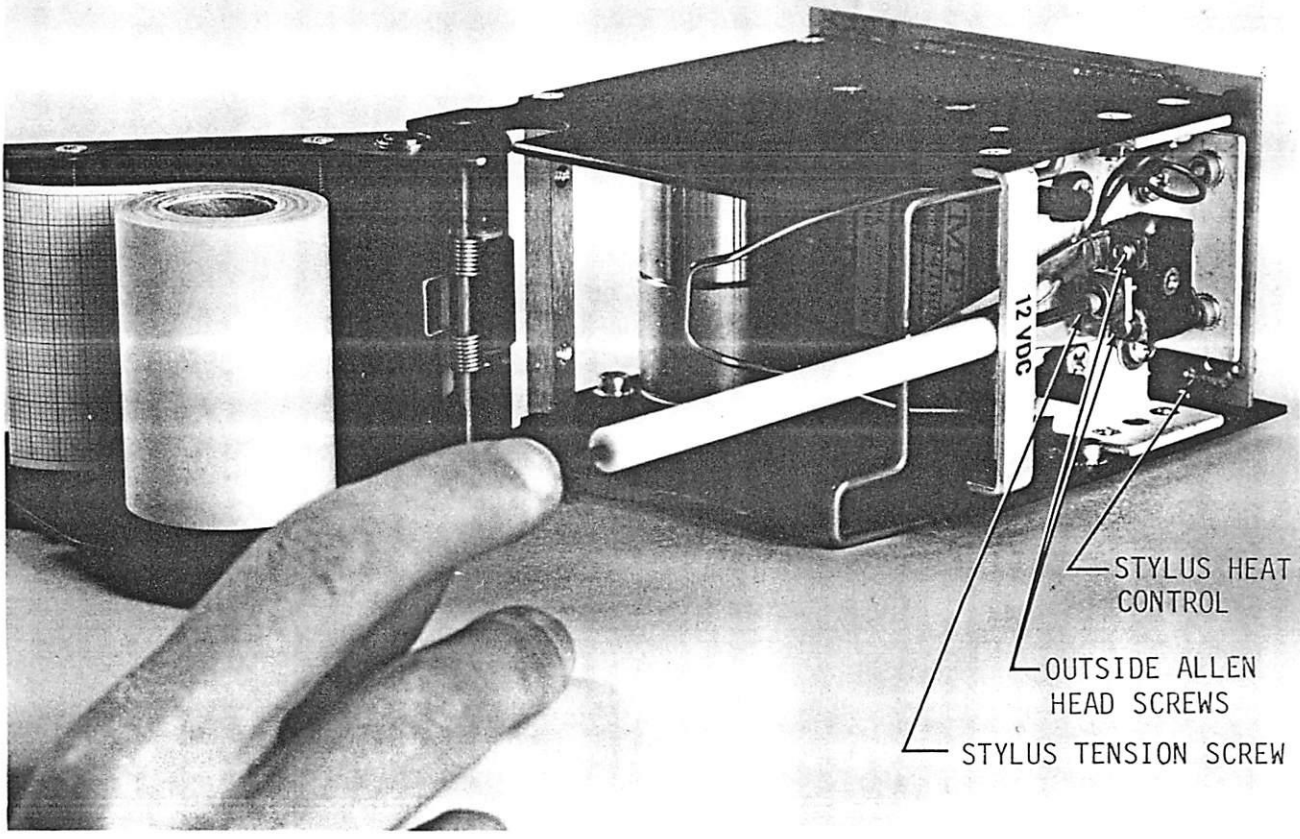

FIGURE 2-6 STYLUS REPLACEMENT AND ADJUSTMENT

## SECTION III

### CIRCUIT DESCRIPTION

#### 3-1. INTRODUCTION

This section provides a detailed description of the circuits contained in LIFEPAK 6 Cardioscope/Recorder and DC Defibrillator modules. The section is divided into three major parts. A brief general functional or block diagram description of each module of the LIFEPAK 6 is presented first. The subsequent parts are presented by Cardioscope/Recorder module followed by the DC Defibrillator module.

#### 3-2. FUNCTIONAL DESCRIPTION

The LIFEPAK 6 block diagrams of Figures 3-1 and 3-2 provide an overall view of the system operation in terms of its two modules. Schematic diagrams of the major circuits are provided later, in the detailed discussion, to allow for examination of the circuits from two levels while reading the circuit descriptions.

NOTE: In rare instances the in-text schematics provided in this section may differ slightly (e.g., component values) from the configuration that the user may have. This would occur only if the PCB board in question was a different revision than the one presented in text. In any case, the engineering schematic in Section 6 would carry the applicable configuration and interim change information noted in the Change Information Section at the rear of this manual.

- 3-3. Monitor Module Circuits. The monitor module circuit functions portrayed in Figure 3-1 are incorporated in the (1) preamplifier, (2) rate, (3) no-fade, (4) recorder, (5) display, (6) charger, and (7) power supply and deflection printed circuit boards, and in the front panel controls and displays. The numbers 1 through 7 assigned to individual blocks in Figure 3-1 correspond to the numbers in the above listing of circuit boards. They therefore indicate which board contains the circuitry for a given function.

The preamplifier board accepts ECG signals from the patient, either via five-lead cable or defibrillator paddles, sums the cable signals into seven combinations, preamplifies the signal to reject common-mode, spurious DC and power-line-frequency components, and interposes electrical isolation between the patient and subsequent amplification and signal processing.

The rate board provides ECG final amplification, signal calibration, and display size control. In addition, it detects the R-wave portion of the ECG for each successive systole event, generates cardioversion synchronization pulses for defibrillator module use, and produces systole sound, heart rate alarm, and heart rate digital outputs.

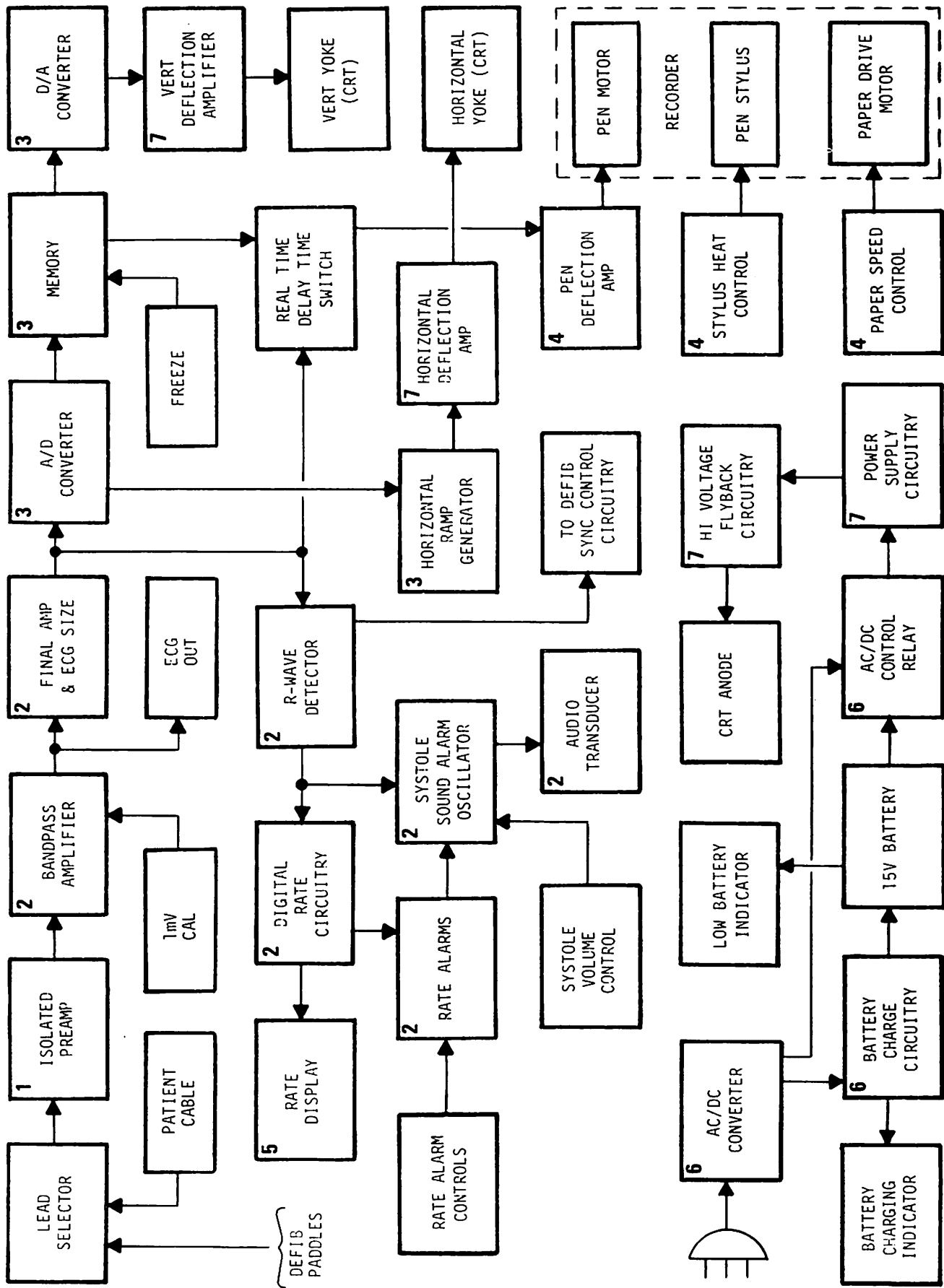

FIGURE 3-1. BLOCK DIAGRAM CARDIOSCOPE/RECORDER

### 3-3. Monitor Module Circuits (Continued).

The no-fade board samples the ECG at a high rate, converts each sample to digital form, stores successive samples in memory, reads out the memory store representing the past 5 seconds of ECG waveform, converts that readout to analog form, and generates a horizontal sweep ramp as a time base for CRT display of the readout 5 second history. The power supply and deflection board provides DC supply voltages, CRT anode voltages, and amplification for CRT deflection signals.

The recorder board amplifies the ECG signal for application to the recorder. The signal is either real-time, obtained from the final amplifier in the rate board, or delayed, obtained from the memory in the no-fade board. The recorder board in addition controls recorder stylus heating and recorder paper constant speed drive.

Display board circuits control a digital display of heart rate and a light blink display for each heart beat. The charger board rectifies AC line power, charges a battery as alternative energy source, selects it when line power is unavailable, and monitors battery status.

### 3-4. Defibrillator Module Circuits. The defibrillator module incorporates a control panel, a high-energy storage capacitor and inductor, paddles and a transfer relay for discharge of the charged capacitor, a test load, a one-ampere hour 12-volt battery, a charger, and the main defibrillator board containing the control circuitry.

A gross and abbreviated outline of module functions is traced in the following paragraphs in conjunction with Figure 3-2. A more complete picture may be obtained by studying that diagram in association with the later description of individual circuit boards and their schematics. Dashed lines enclose various blocks to portray the circuit boards housing those functions.

The charger board +12 volt output constitutes the DC supply for all applications in the defibrillator module. To provide it, the charger either rectifies AC line power or relays the battery output. Initial POWER switch depression on the front panel sets flipflop U1 to go on. As one result, charger +12V passes through relay K1, thus establishing various supply voltages. As another result, charge flipflop U4 receives a temporary reset to non-charge state.

The operator having rotated the front panel ENERGY SELECT switch to one of its operative settings, the dump comparator and energy level comparators in monochip U4 senses a fraction of the voltage established in the high-energy storage capacitor. With the fractioning path intact and the voltage representing less than the desired charge, the two comparator outputs will not reset charge flipflop U4 to non-charge. When the operator activates either of two charge switches, the charge flipflop transitions to charge-up state, sending a CD & RLI signal to the charge-up circuit. There, as a result, an oscillator will commence oscillations that cyclically gate-on and gate-off a path through the primary of high-permeance transformer T1. With DC current, driven by the +12 volts,

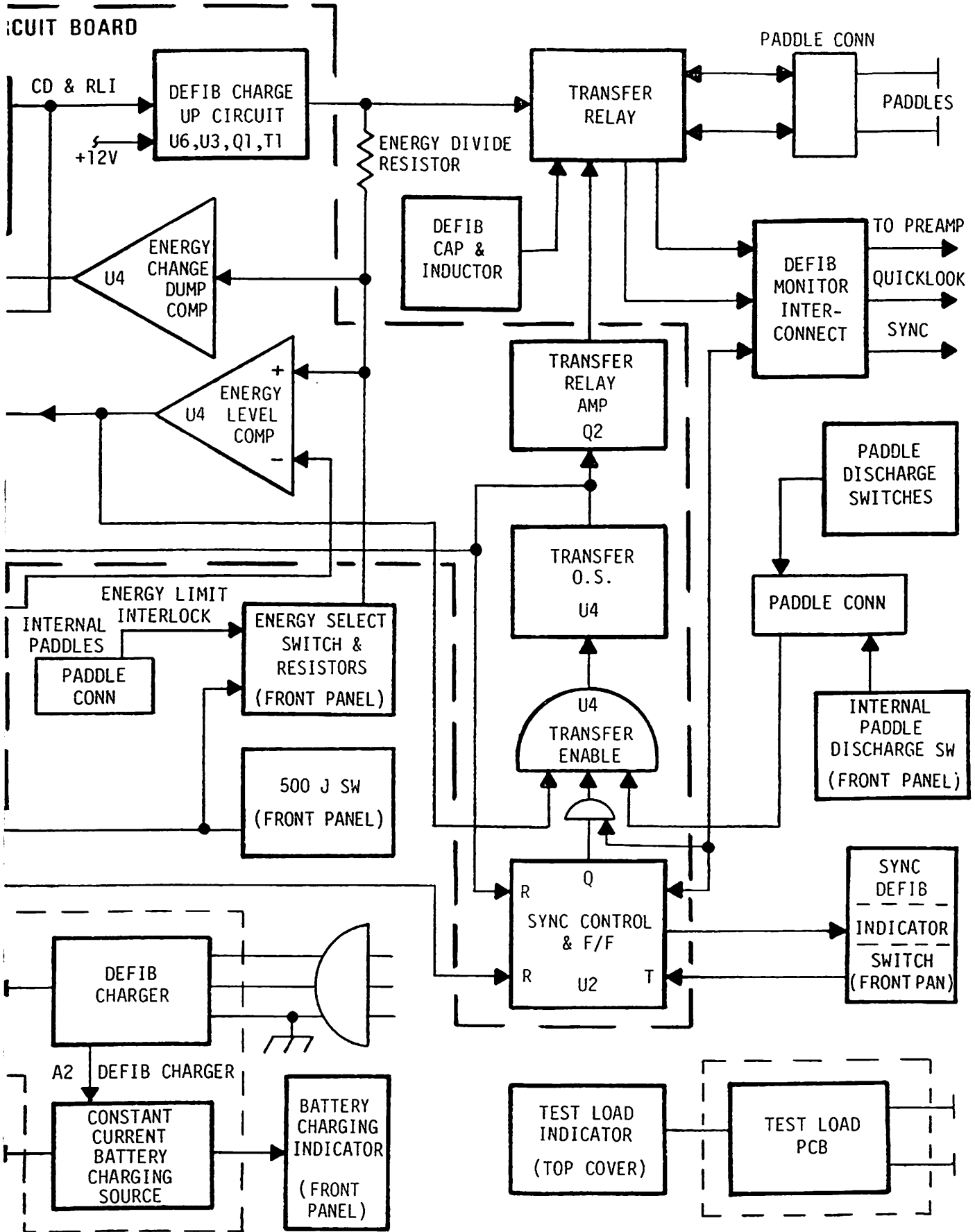
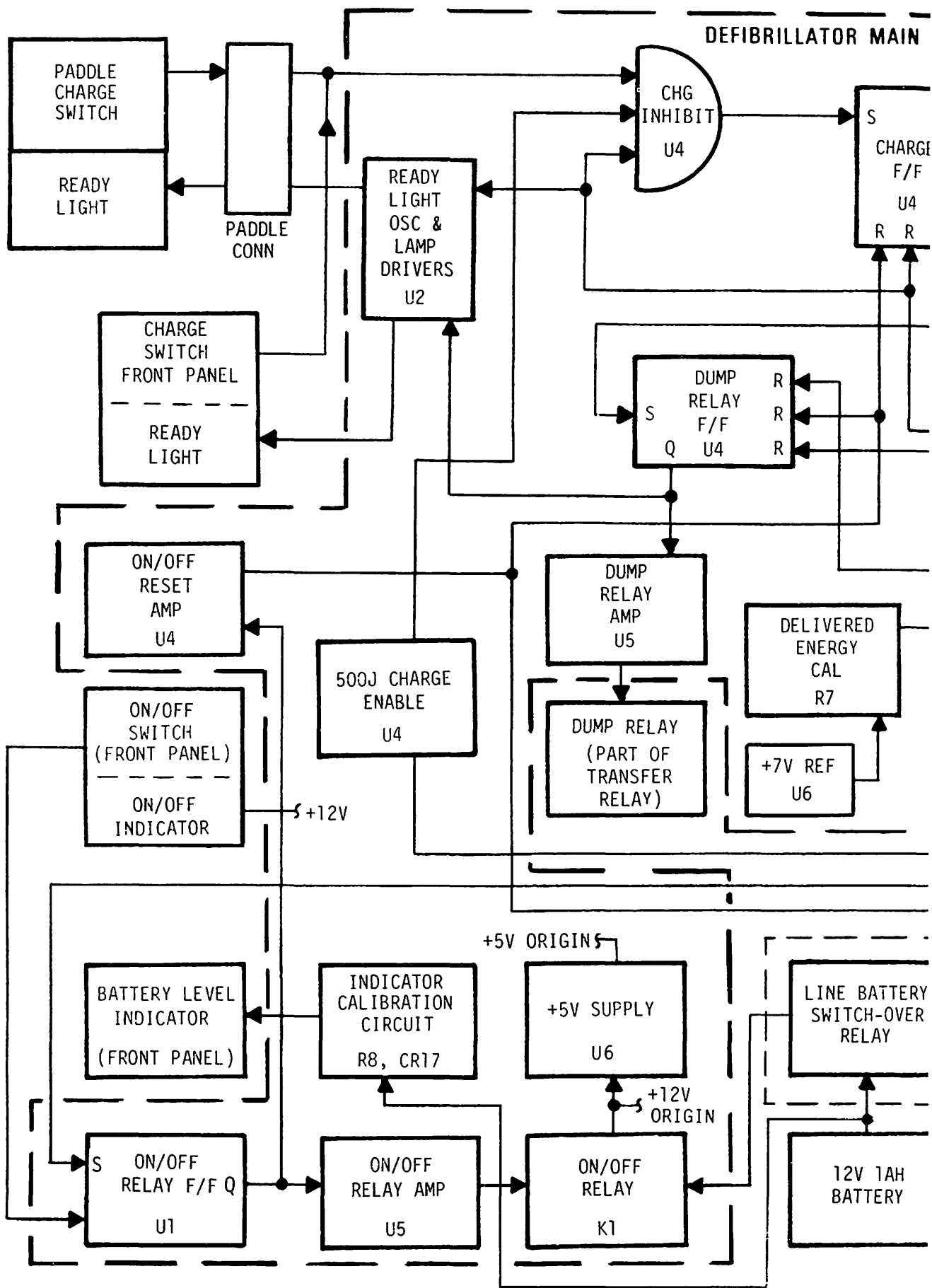

FIGURE 3-2. BLOCK DIAGRAM DC DEFIBRILLATOR



### 3-4. Defibrillator Module Circuits (Continued).

flowing in T1 primary during the on periods, and being interrupted by the off periods, high voltage pulses are induced in T1 secondary and the energy they represent is stored in the capacitor. When the voltage sensed by the energy level comparator reaches the desired level, comparator output transitions, disabling further chargeup by resetting the charge flip flop. With chargeup completed, operator actuation of both external paddle discharge switches or the single internal-paddle switch, with the sync-defib flip flop in U2 in defib mode, enables the transfer relay, effecting capacitor discharge. In sync mode, one more condition is required for capacitor discharge, namely the receipt of a systole pulse through the defibrillator-monitor interconnect.

This simplified, introductory resume neglects various functional sequences, circuit elements, and logic interrelationships. A more complete view is given in the detailed discussion.

### 3-5. CARDIOSCOPE/RECORDER

The following paragraphs 3-6 through 3-12 provide the LIFEPAK 6 Cardioscope/Recorder circuit description presented by individual function, starting with the preamplification circuitry and continuing through the no-fade, cardioscope and recorder display, rate display and power supply circuitry.

The interconnecting wiring diagram in Section 6 provides the complete interconnection data for the sub-assemblies which comprises the LIFEPAK 6 Cardioscope/Recorder.

### 3-6. Preamplifier Board. The preamplifier provides input buffering, lead selection, isolated preamplification, common-mode rejection, and rejection of DC and power line frequencies. (See Figure 3-3 and 3-4).

A. Input Buffers and Drive. All ECG connections between the patient's electrodes and the monitor are made via five-lead cable, each lead being individually shielded. The ECG input from the patient is channeled to the preamplifier through four of these leads and circuit connector, J1. Each of the four input leads is buffered by its own operational amplifier, physically 1/4 of module U1. Operated at unity gain, each buffer presents a high input impedance and a low output impedance to the Wilson network in the next stage. All four op amps being part of the same monolithic quad, their characteristics closely match. This is a critical consideration in a high-resolution diagnostic application.

The three buffered outputs from the arms and left leg are summed and averaged by resistors R13, R14, R15. The result, inverted in U2 and applied to the right leg, drives that member with a common-mode cancelling signal that increases the common-mode rejection ratio of the preamplifier. The arm and left leg buffered outputs are in addition connected to the Wilson resistance network, which provides a summing array. Various sum fractions constitute the network outputs corresponding to various lead combinations.

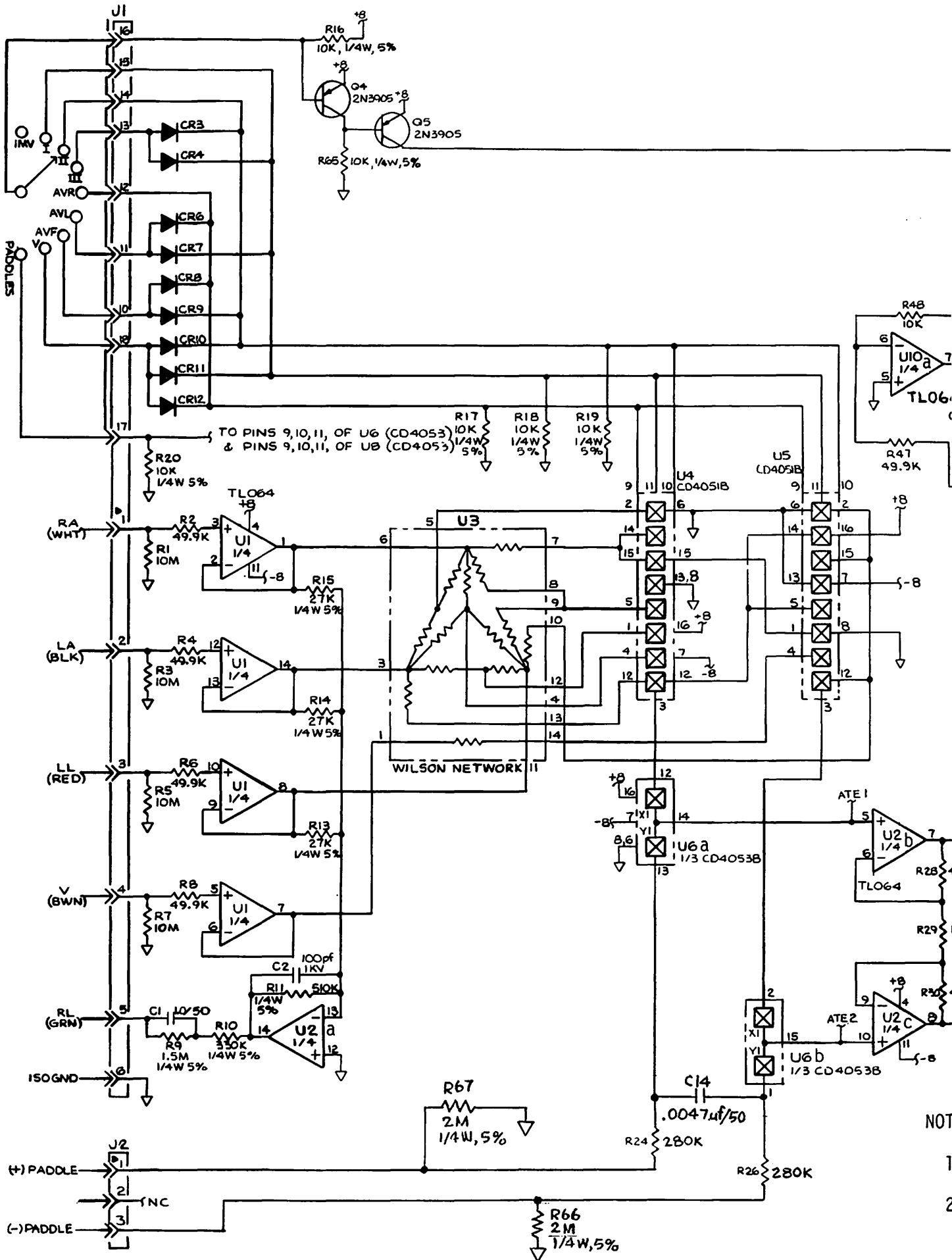



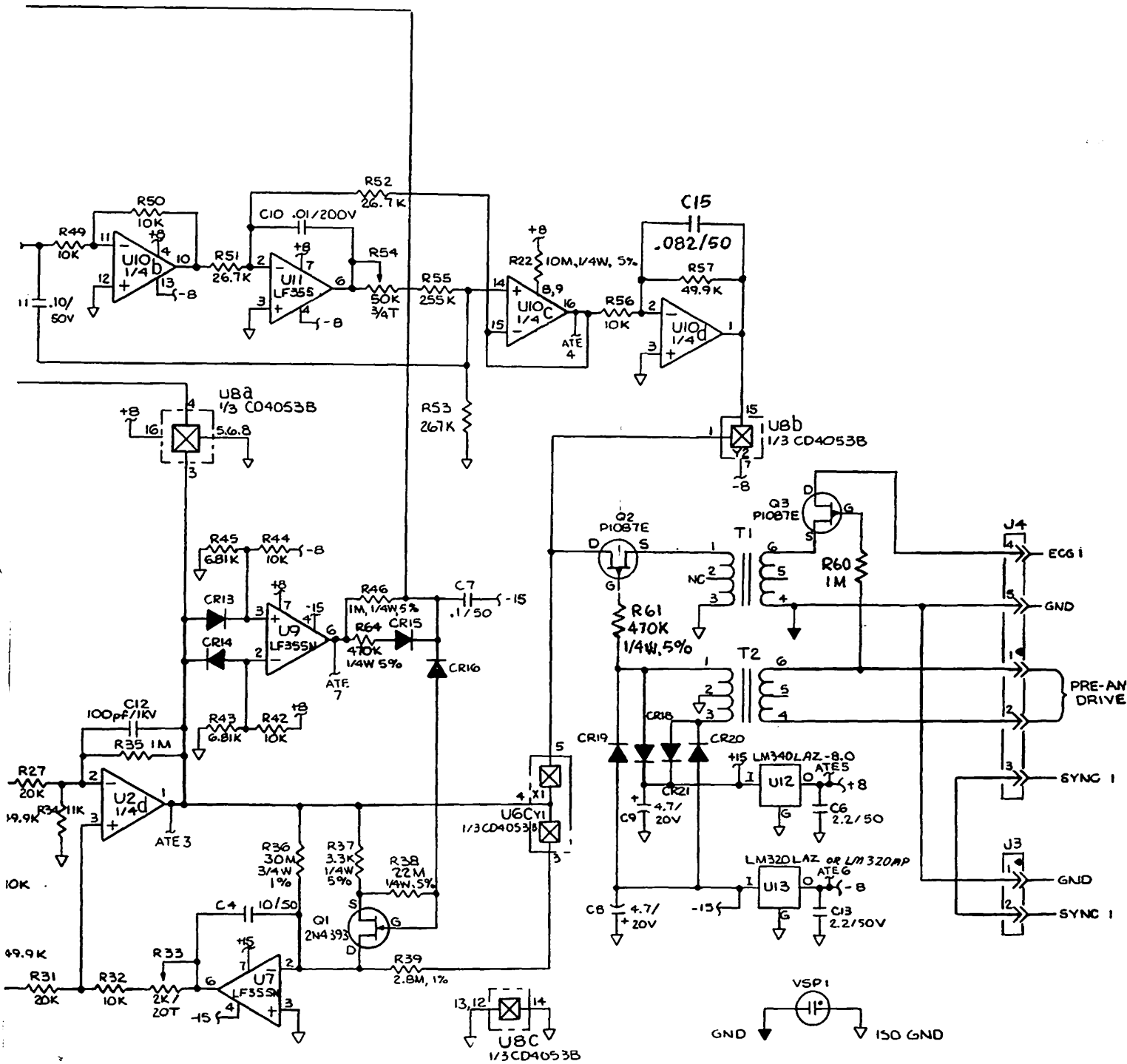

NOTES: UNLESS OTHERWISE SPECIFIED

1. ALL RESISTORS ARE IN OHMS, 1/8W, 1%.
2. ALL CAPACITORS IN MFD/WVDC.

800101

FIGURE 3-3. PREAMPLIFIER BOARD SCHEMATIC

3-7/3-8

### 3-6. Preamplifier Board (continued)

B. Lead Selection. The setting of a nine-position switch on the front panel determines the sources of input to the preamplifier.

1. In position STD, there is no preamp input. A 1 mv standardization voltage can then be applied independently to a later amplifier stage through actuation of another front panel control.
2. Each of the next seven positions uniquely selects one of seven possible lead combinations.
3. The final switch position selects the defibrillator paddles as the ECG signal source.

The seven different lead combinations are switch-selected through diodes CR1-12. In any given setting, a unique one of seven binary codes is applied as control input to pins 9, 10, and 11 of solid-state units U4 and U5. Electrically, U4 and U5 are each the equivalent of a multiposition selector switch. The output connection of each appears at its pin 3. Therefore, depending on the binary control input, any of seven combinations of analog signals originating in the V, LL, RA and LA leads can be made available at the U4 and U5 outputs.

Somewhat arbitrarily, the U4 output can be thought of as the signal and the U5 output as the reference or signal return. Signal and return paths are completed to the Instrumentation Amplifier via solid state switches U6a&b, provided the front panel selector is not at position PADDLES. At position PADDLES, the selector connects an 8-volt control potential to U6 so that the Amplifier input is obtained from the defibrillation paddles.

C. Amplification. Whether obtained from the paddles or the patient cable, the signal is applied through U6a&b to a differential amplifier that employs operational amplifiers U2b, U2c and U2d. After the first stage of amplification, the signal and reference are applied inversely to difference amplifier U2d, a process that makes for AC common-mode rejection. The rejection efficiency is especially high because the three op amps are monolithic and therefore closely matched in operating characteristics.

Overall the three op amps provide a nominal AC gain of 500. DC-reject circuits feed back through U7 to provide DC-cancelling inputs to U2d, pin 3. The feedback is accomplished either via an integrating circuit involving an RC time-constant determined basically by the values of R36 and C4, or (for larger DC swings) by a faster reacting circuit involving U9, Q1, and an RC time-constant set basically by R37 and C4.

The normal speed circuit is enabled as long as the absolute value of the instantaneous DC output at U2d is less than 3.2 volts. However, this DC output level may be momentarily exceeded following defibrillation discharges or lead selection changes. In that case, the output of comparator U9 transitions to a logic high, charging

3-6. Preamplifier Board (continued)

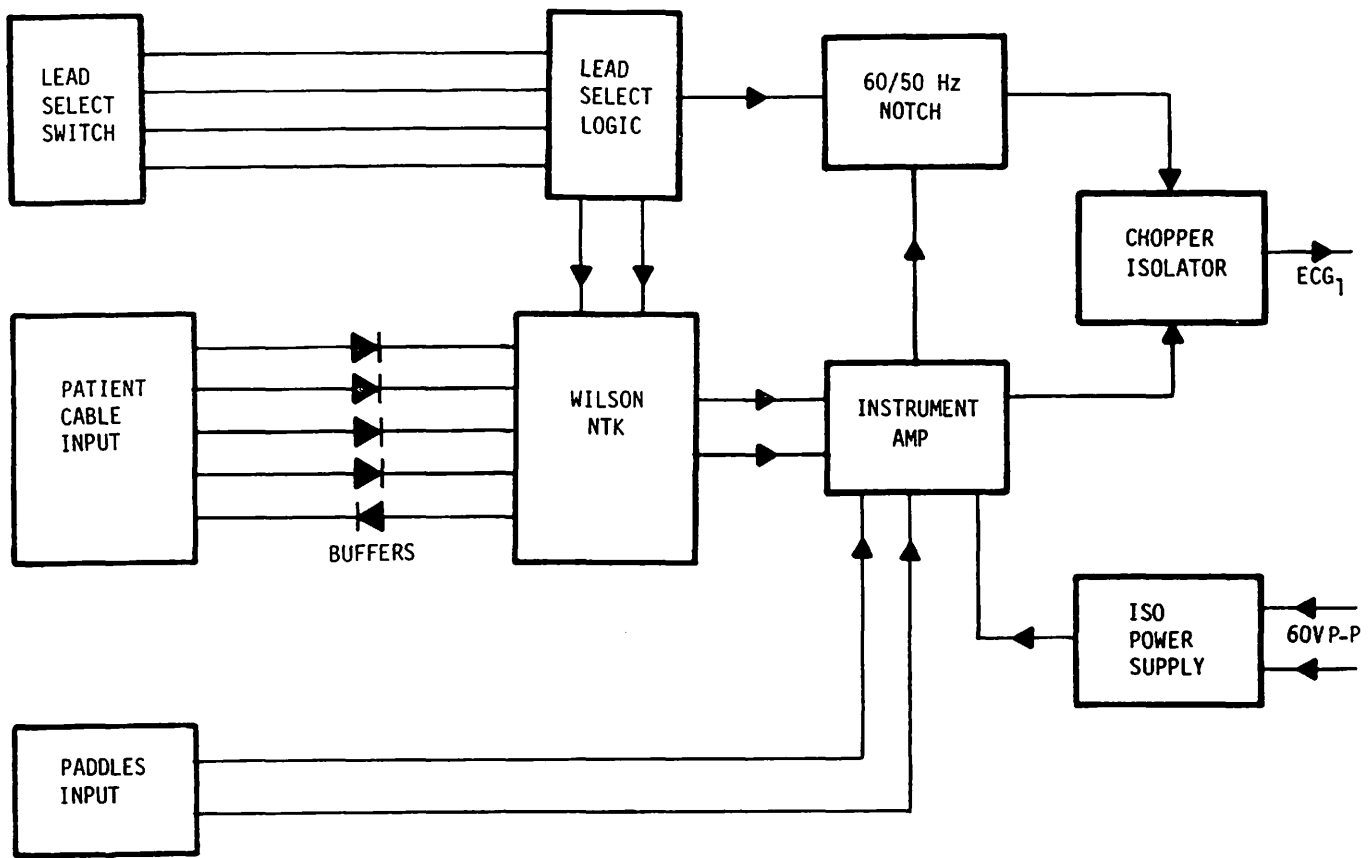

FIGURE 3-4. PREAMPLIFIER BOARD, BLOCK DIAGRAM

C. Amplification (continued)

up C7, and thereby applying a high to Q1 that causes that FET to conduct. As a result R37, much lower in resistance than R36, is inserted in the RC circuit and greatly reduces its time constant. The resultant quick-acting inverse feedback through U7 rapidly restores U2c output to zero. With zero DC output re-established, U9 output swings low again, turning off Q1 and returning the instrumentation amplifier to normal operation.

Common-mode rejection is maximized by adjusting potentiometer R33 in the DC-reject circuit.

With cable input selected, the instrumentation amplifier output is conveyed through switch U6c to Q2, the input to the chopper amplifier. In that case, the instrumentation amplifier frequency response is from 0.05 - 40 Hz.

### 3-6. Preamplifier Board (continued)

#### C. Amplification (continued)

In contrast, with paddle input selected, the instrumentation amplifier output is switched through U8a to a notch filter. With paddles selected, moreover, the U2c output pin is connected through U6c to R39. This places R39 in parallel with R36, thereby decreasing the normal RC time constant in the DC-reject circuit more than tenfold. As a result low-frequency DC variations such as often encountered with paddle use are rejected, the accompanying effect being to increase the preamplifier low-end frequency response limit to 1 Hz, as opposed to the 0.05 Hz low-end limit when cable input is selected.

- D. Notch Filter. When paddle input is selected for monitoring, a possibility exists for an artifact being present on the ECG in the form of a component at line power frequency (50 or 60 Hz). To remove that component, the instrumentation amplifier output is switched through U8a and applied to an active band-reject (notch) filter.

The circuit employs operational amplifiers U10a,b,c, & d, and U11. The first op-amp stage divides the input in a fixed proportion at all frequencies so that the reduced signal to the next three stages (the filter proper) will not saturate that section. In the filter, multiple feedback circuits involving U10b, high-gain U11, and U10c produce sharp band-reject at 60 Hz (or 50 Hz for European application). Stability of the high rejection Q is inherent, even if circuit component values drift with time. Following the filter stages, U10d restores the signal at other than notch frequency to its original input level to U10a. The U10d output is switched through U8b to the chopper amplifier.

- E. Isolation Chopper. To further shield patient and ECG signal from equipment power, the preamplifier output is passed through an isolation transformer. However, inasmuch as a transformer is ineffective at ECG signal frequencies, the signal is first modulated onto a much higher frequency, a carrier; it is the signal-modulated carrier that is applied to the transformer.

The carrier is derived from a 20-kHz square wave generated in the main power supply and conducted to the primary of transformer T2 and the gate of transistor Q3. The 20-kHz wave, reappearing at T2 secondary, is also applied to the gate of Q2. Both transistors therefore gate on during each negative-going half of the 20-kHz wave. The preamplifier output is applied at Q2 drain, and chopped in Q2 at 20-kHz frequency. The resulting carrier, amplitude-modulated by the ECG signal, is transformed by transformer T1. The T1 output is half-wave rectified by Q3 and conveyed to the rate board. There a shunt capacitor removes the 20-kHz component, in effect shorting it to ground, while detecting the ECG modulation for subsequent amplification.

### 3-6. Preamplifier Board (continued)

F. Isolated Power Supply. The 20-kHz output of transformer T2 in addition serves as the isolated input to the preamplifier power supply. As the opposite ends of T2 secondary swing positive with respect to ground, they are alternately connected through diodes CR18 & 21 to regulator U12, which provides +8 volts. Similarly, CR19 & 20 connect the negative swings to U13, which provides -8 volts for the board. The regulators ensure that CMOS ratings are not exceeded.

3-7. Rate Board Circuitry. The rate board provides ECG final amplification, signal calibration, and display size control. In addition, it detects R-waves and generates cardioversion sync, systole sound, rate alarm, and rate digital outputs. Figure 3-5 provides an overall block diagram of the rate board showing interface with other stages. Figure 3-6 provides a full schematic of the rate board circuitry.

A. Bandpass the Final Amplifier. On the rate board the preamplified ECG signal arriving at P1-17 is applied to a bandpass amplifier whose output is U1, pin 7. Capacitor C2 bypasses 25-kHz harmonics to ground, thus removing them from the input signal. Capacitor C3 blocks the DC component of the input signal. The bandpass amplifier provides a midband gain of two. This gain acting in cascade with the preamplifier gain of approximately 500 raises the ECG signal from the patient by a factor of 1000 at U1a output.

Inasmuch as the typical maximum amplitude of the ECG signal generated in a human is 1 millivolt, the typical counterpart amplitude at U1, pin 7, can be expected to be 1 volt. To verify that the circuits are operating normally and/or to calibrate the voltage equivalence of a given CRT display, U1a, pin 6 input simulating the effect of a 1-mv input to the preamplifier can be produced by pressing the 1 mv CAL button on the front panel. This action connects -12V to J1-6. By means of potential divider network R2, R6, a fraction of this -12V is applied to the inverting terminal, U1, pin 6.

The result is a negative step of one volt in the output signal from U1a. This step, amplified and converted in succeeding stages along with the ECG signal (if any) will be evidenced by a vertical step negative displacement of the display in the CRT and recorder. With circuit normality indicated and no subsequent gain adjustments made, the visual step can be used as a deflection reference equivalent to a 1-mv ECG input.

The output of U1a is connected via P1-8 to a test jack and divider on the main flex assembly. There, depending on plug insertion (ring-tip or ring-tip-sleeve) the test signal, used for field service recording or other measurement purpose, is equal to the full U1a output or to 1/1000 of that output, the latter thus being normally equal to the ECG input from the patient.

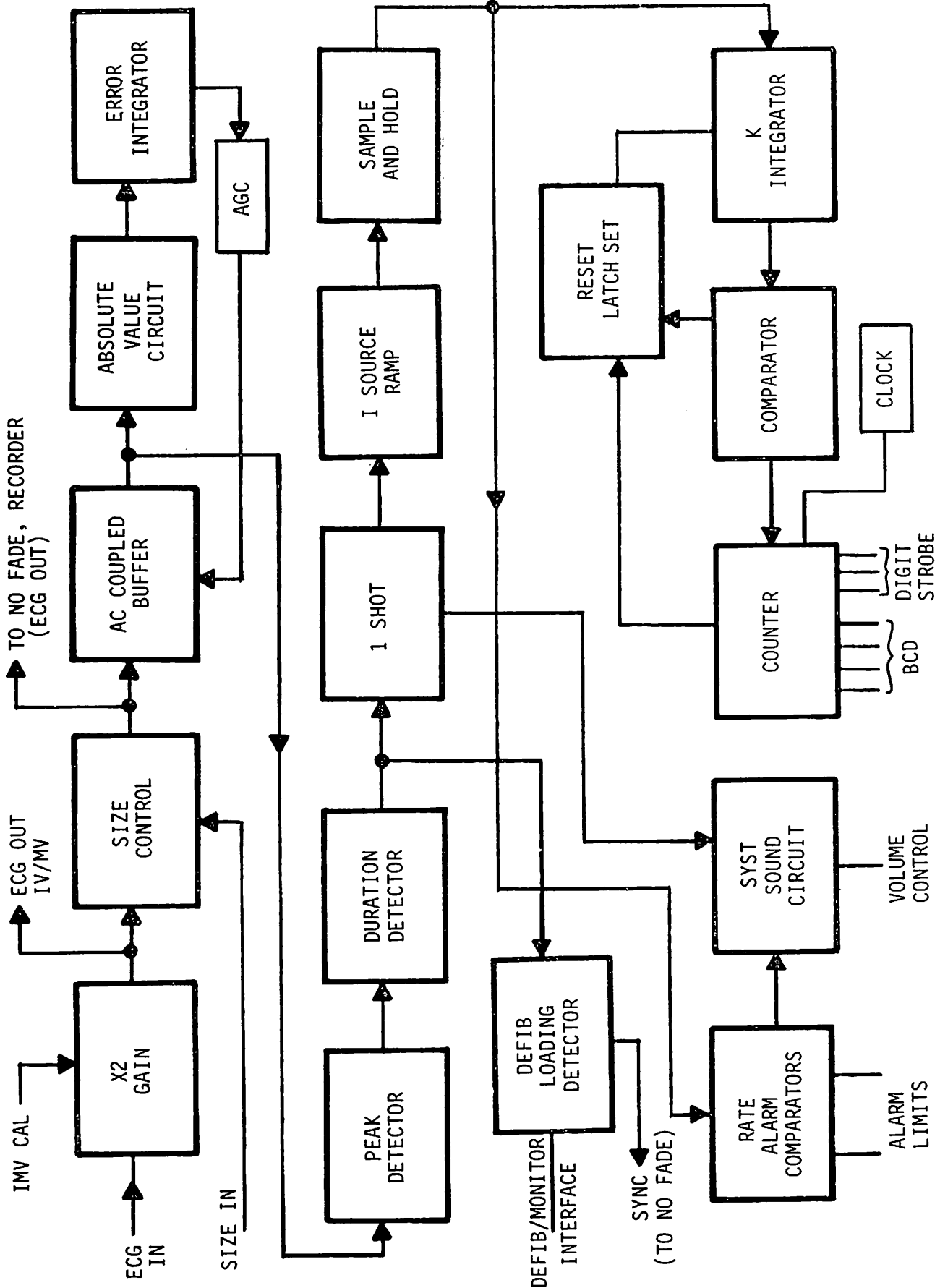

FIGURE 3-5. RATE BOARD - BLOCK DIAGRAM

### 3-7. Rate Board Circuitry (continued)

#### A. Bandpass the Final Amplifier (continued)

For gain, control, a potentiometer (ECG size) on the front panel is connected to P1-5. In conjunction with R8, it forms a potential divider in the output load circuit of U1a. The pot setting thus determines the vertical deflection of the CRT and recorder displays.

Depending on that gain setting, a variable fraction (from 0 to 5/6) of U1 output is applied to final amplifier U1b which provides a gain of 6. The output is connected to P1-3 as signal ECG OUT. Output of buffer U3a is used as ECG real time signal to the recorder. With the Gain Control at its maximum (5/6) setting, the peak amplitude of signal ECG OUT is typically 5 volts (i.e.,  $6 \times 5/6 \times 1000$ ).

- B. R-Wave Detection. R-wave amplitude can vary substantially with time during monitoring of the patient. Therefore the first major function of the R-wave processing circuits is to sense the ECG R-wave peak amplitude and reduce it to an essentially fixed reference level. This automatic gain control involves a variable gain stage, an AC-coupled buffer stage, and a feedback loop consisting of an absolute-value circuit, peak detector, error integrator, and voltage-controlled resistance network.

That AGC loop will now be examined. The ECG signal, after final amplification, appears at op amp U2a input. The variable-gain of that stage is controlled by the AGC-regulated resistance of Q8. Capacitor C6 couples the AC components of U2a output to U1c, a unity-gain buffer. The coupling components (R23, C6) selectively attenuate frequencies below about 3 Hz, thus discriminating against P and T waves and favoring the R-wave spectrum. The buffer output, available at test point 3, enters the AGC feedback loop via an absolute detection circuit, using U2b and U1d.

That circuit produces a positive-going ECG waveform at U1d output regardless of true original ECG polarity. For example, if the signal at TP3 is +V, its unity gain inversion in U2b causes CR7 to conduct and thus provide a path for application of -V through 10K ohms as inverting input to U1d. That summing amplifier thus experiences two inputs: -V through 10K ohm and +V through 20K ohm. Its scaled inverted output is therefore  $-1(-V \times 2 + V \times 1) = +V$ . On the other hand if the signal at TP3 is -V, CR8 conducts, providing no path for U2b output. The summing amplifier thus has but one input (-V), which it inverts to produce output +V. To restate, all wave-shapes appear at U1, pin 8 as positive-going and are conducted through CR9 to charge up C13. Because +2.8V clipping voltage is applied to CR10 cathode, C13 charge-up is limited to +2.8 volts. Rapid variations in absolute ECG signal level are integrated by the C13, R34, R28, R29 combination. The average value over an RC time period is presented to U2c as an error signal. The error reference is -2V maintained at the junction of R30 and R29.

### 3-7. Rate Board Circuitry (continued)

#### B. R-Wave Detection (continued)

The error signal is inverted and integrated at U2, pin 14 and applied to the gate of FET Q8, in order to vary Q8 drain-to-source resistance in proportion to signal strength.

For peak detected voltages of more than +2 volts across C13, the error signal to U2c, pin 13 swings positive, and the output negative, so that CR15 is not conducting. Thus the effective integrating capacitance increases, and AGC damping periods lengthen.

With zero ECG signal, the steady-state C13 voltage is zero, the error signal reference -2 volts is applied to U2c, the Q8 gate voltage is at its maximum plus level, and drain-source resistance R is minimum. The gain at U2a, inversely proportional to  $1+R$ , is thus maximum. At high ECG signal levels such that the error signal to U2c is at its maximum positive level (+0.5V), the Q8 gate voltage is negative and Q8 resistance is maximum. Therefore U2a gain is minimum.

- C. R-Wave Detector. The ECG signal, its average amplitudes having been brought to a reference level by AGC, is now examined for the presence of an R-wave. This process involves filtering, differentiation, slope magnitude detection, and duration detection.

The filtering function involves two op amp stages employing U3b and U3c. Together they provide a pass band from 5 to 17 Hz, passing the principal R-wave harmonic components. Stage U3b emphasizes the low end of the spectrum and effectively provides the high-end roll-off. Stage U3c favors the high-end of the spectrum and effectively provides the low roll-off.

Differentiation of the bandpassed ECG waveshapes is provided by stage U3d, with R25 and C8 the basic components sensing the instantaneous slope of the wave. Capacitor C7 serves to pass the relatively low frequency harmonics of the differentiated wave, while rejecting the high frequency spikes caused typically by noise or other artifacts.

The slope detector produces output at U2d in a comparator amplifier configuration. Circuit purpose is to produce a steady positive DC output as long as the absolute amplitude of the differentiated signal exceeds a reference level. Specifically, U2d output goes to +12 volts when the slope of the R-wave exceeds a fixed value and thereby causes the output of U3d to exceed 1.2 volts absolute.

With an unvarying input to U3d, its output at pin 16 is 0 volts (slope = 0). Under this condition, input pins 12 and 11 of U2d are maintained at -0.6 and +0.6V respectively by -12V and +12V resistance ladders. The difference input is then -1.2 volts ( $= -.6 - (+.6)$ ). This large input causes the op amp to saturate, producing an output of -12 volts.



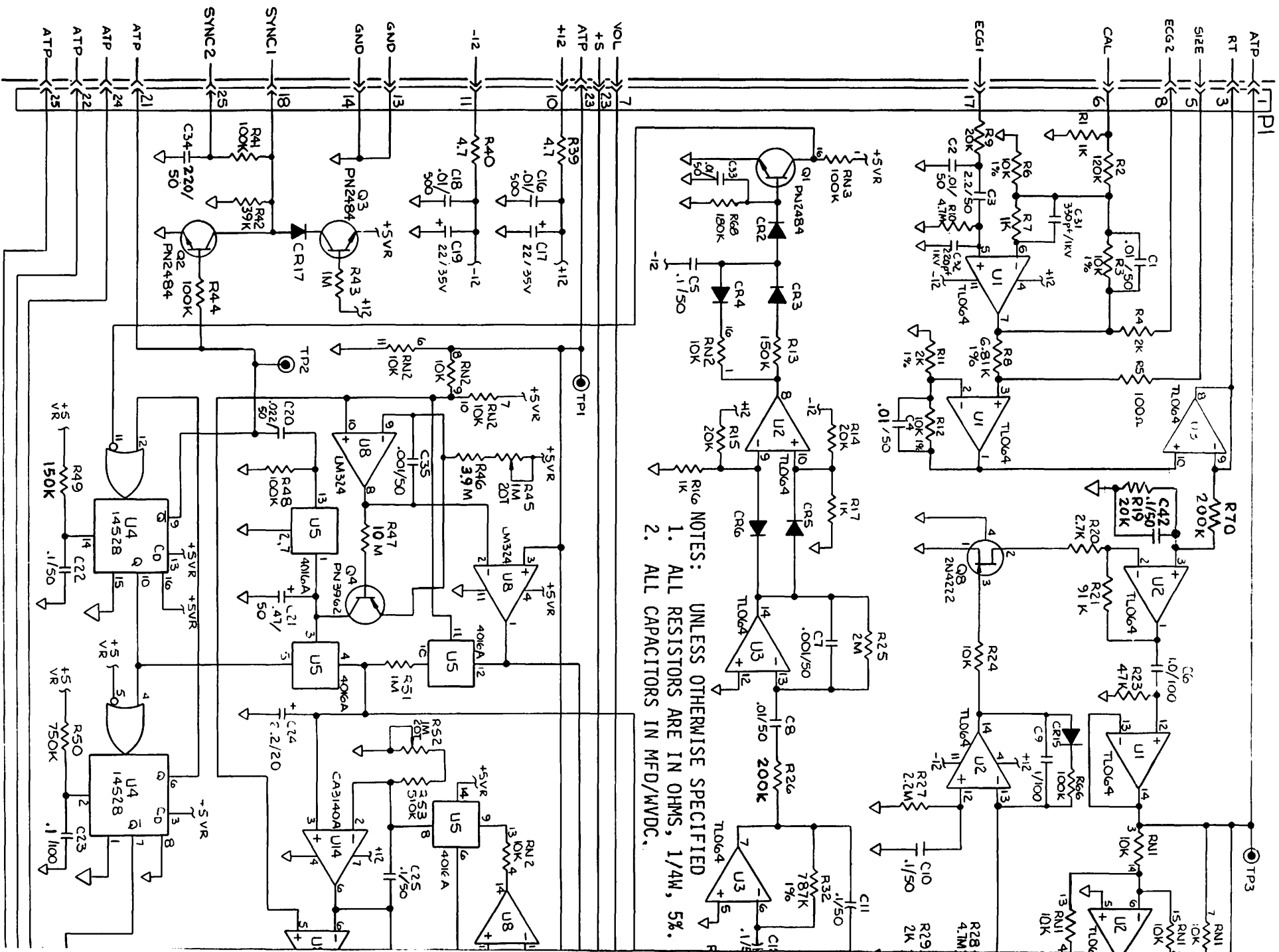

UNLESS OTHERWISE SPECIFIED  
 1. ALL RESISTORS ARE IN OHMS, 1/4W, 5%.  
 2. ALL CAPACITORS IN MFD/WVDC.

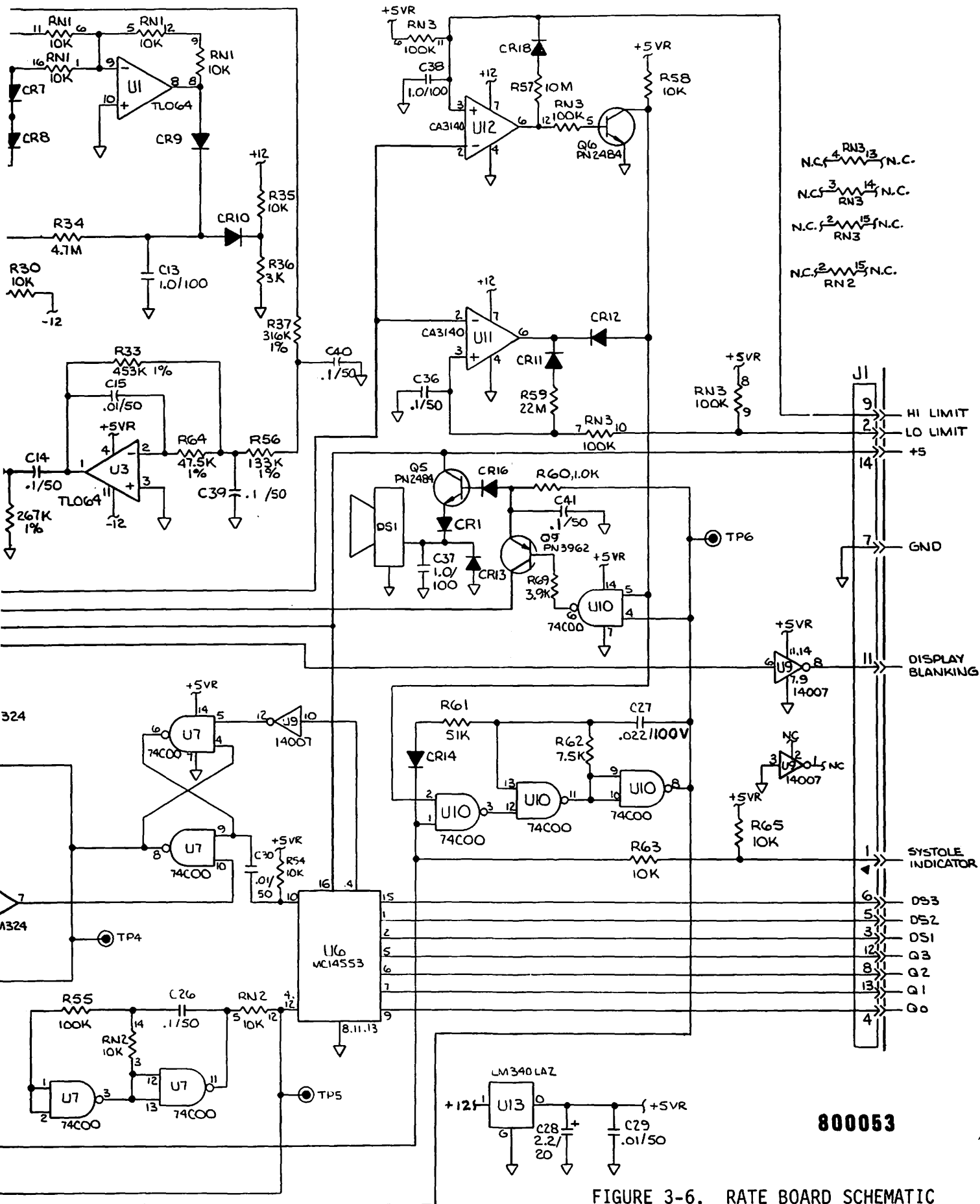

800053

FIGURE 3-6. RATE BOARD SCHEMATIC  
3-16/3-17

Jan 1979

### 3-7. Rate Board Circuitry (continued)

#### C. R-Wave Detector (continued)

During a rapidly changing ECG input to U3d, such as experienced in the R-wave, the U3d output will equal or exceed 1.2V, either positive or negative. When it is +1.2V, U2d input becomes +0.6V (the constant threshold across CR5 accounting for the 0.6V drop). The U2d output is then zero (+.6 - (+.6)).

Finally, when U3d absolute output exceeds 1.2V by more than a millivolt, U2d input difference goes positive and the comparator responds with a +12 volt output.

The circuit associated with transistor Q1 senses whether a positive 12-volt output of U2d has lasted the requisite minimum of 20 milliseconds.

With -12V output (indicating waveslope less than threshold), C5 is initially uncharged. When ECG slope exceeds threshold, U2d output becomes +12V and C5 charges through CR3 and R13. The RC time constant of this path is 20 ms. When the slope eventually drops below threshold, U2d output reverts to -12V and C5 discharges quickly through CR4, the RC of that path being 1 ms.

When U2d output has been positive for almost 20 ms, the increasingly positive voltage transmitted via CR2 to the base of Q1 causes that transistor to conduct. As a result Q1, pin 16 goes low, this constituting a signal that a valid R-wave has been sensed.

Quick shutoff of Q1 is effected by C33 discharge through R68, once U2d reverts to negative output.

- D. Cardioversion Sync Generation. An affirmative R-wave detection output from Q1 is inputted at U4a as a logic low to that one-shot multivibrator. Up to that time, the flip flop has been in its stable condition, with its  $\bar{Q}$  and Q terminals high and low (+5 and 0 volts) respectively. Now, with pin 11 pulsed low, the single-shot transitions to its unstable, complementary condition, which it will sustain for the next 10 milliseconds.

One result is that  $\bar{Q}$  becomes a low during that 10 ms. It thus drives the base of Q2 low. Up to that moment, with the defibrillator and monitor modules interfaced and the SYNC pushbutton actuated on the defibrillator panel, a constant current source in the defibrillator has been supplying conduction current to Q2 via P1-18. Now, with Q2 base driven low by  $\bar{Q}$ , Q2 switches off and its collector swings high. That high is conducted to the no-fade board through P1-25, as signal SYNC to generate an R-wave marker on the CRT. In addition, in the defibrillator, the SYNC signal enables a cardioversion discharge.

### 3-7. Rate Board Circuitry (continued)

- E. Rate Measurement. The further consequences of the detection of an R-wave involve rate sensing and display. They are discussed below in conjunction with the pulse diagrams of Figure 3-7.

As soon as U4a has transitioned to its 10ms unstable state, Figure 3-7(b) its Q output high to a second one-shot multivibrator, U4b, drives that unit to its unstable stage, whose duration is 175 milliseconds, Figure 3-7(c). The resulting  $\bar{Q}$  output low is conducted through J1-1 and on to the display board to cause the systole LED to light for that 175 ms. The same  $\bar{Q}$  low enables the U10, pin 8, audio alarm oscillator for that interval. As a result, the audio alarm sounds with an interrupted beep whose period approximates that of the heart.

The feedback loop of Q output high from U4b to the input of U4a serves to prevent any new (and presumably spurious) R-wave detector output from retriggering the 10 ms single-shot during the 175-ms refractory period.

During the previous heartbeat period, just after the 10-ms single shot had reverted to its stable condition, and with U4a- $\bar{Q}$  having returned to high, a positive pulse through C20 had briefly (for about 2 ms, as determined by R48, C20) enabled switch U5a, thus connecting U5a, pin 1 to ground and draining off charge on C21. After the 2 ms period, the U5a gate has reopened, allowing C21 to start recharging at a steady rate determined by the constant current through transistor Q4. As a result, the voltage across C21 has since then been climbing steadily with time, as in Figure 3-7(d). That climb essentially stopped when, in its current excursion to the unstable state, the 10-ms single shot produced a Q output high to U5b. This control signal causes that gate to connect C24 in parallel with C21. The charges on C21 and C24 then rapidly reaches a state in which the charge ratio equals the capacitance ratio. At the end of the current 10-ms state, the U5b connection will open, C21 will again be shorted temporarily to ground through U5a, pins 1 & 2, and then a new C21 recharge cycle will start. Meanwhile, the voltage across C24, Figure 3-7(e) serves as a stored sample proportional to the length of time between the previous detected R-wave and the most-recent detected R-wave. Thus the voltage across C24 is an inverse measure of the current rate at which the heart is beating. The effect of C24 sampling and storage of C21 charge buildups during successive heartbeats is suggested in Figure 3-8. It serves to average short term variations yet react quickly to sustained changes.

In the first half of the mock history illustrated, a 60-BPM rate is experienced. During each heartbeat period, therefore, V21 (the voltage across C21) ramps to approximately 1 volt. At essentially the end of each ramp, the difference between the charge on C21 and that on C24 is distributed to C24. For simplicity, the initial charge on C24 is assumed zero. Even in this worst case, it is seen that within a few heartbeats the voltage across C24 has staircased to a virtually stable level, asymptotic with the C21 level.

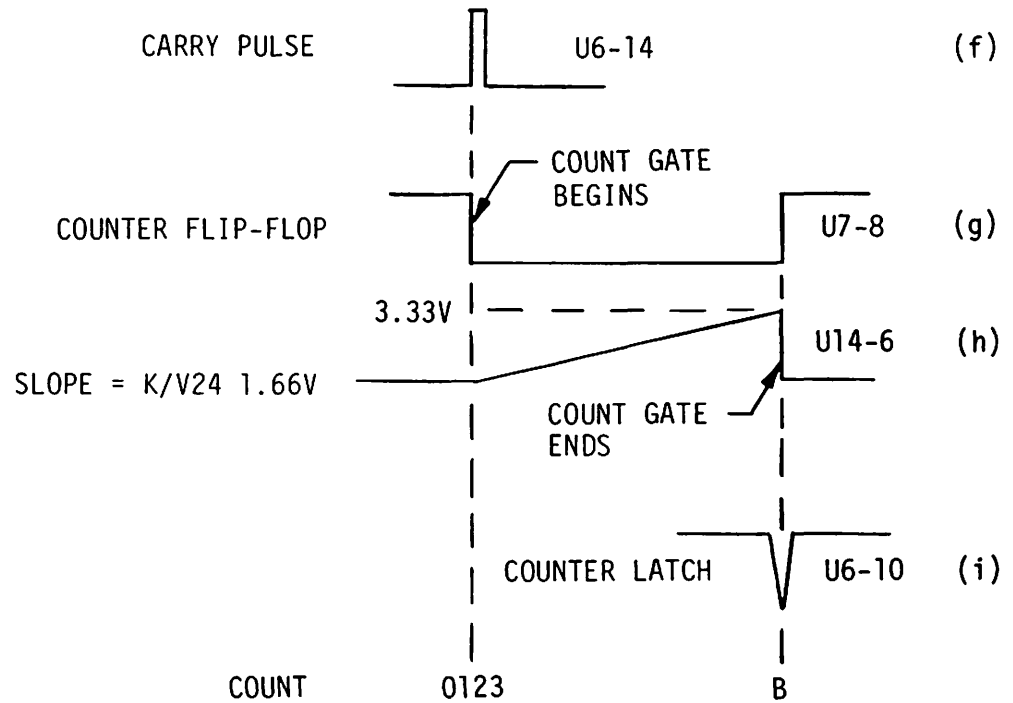
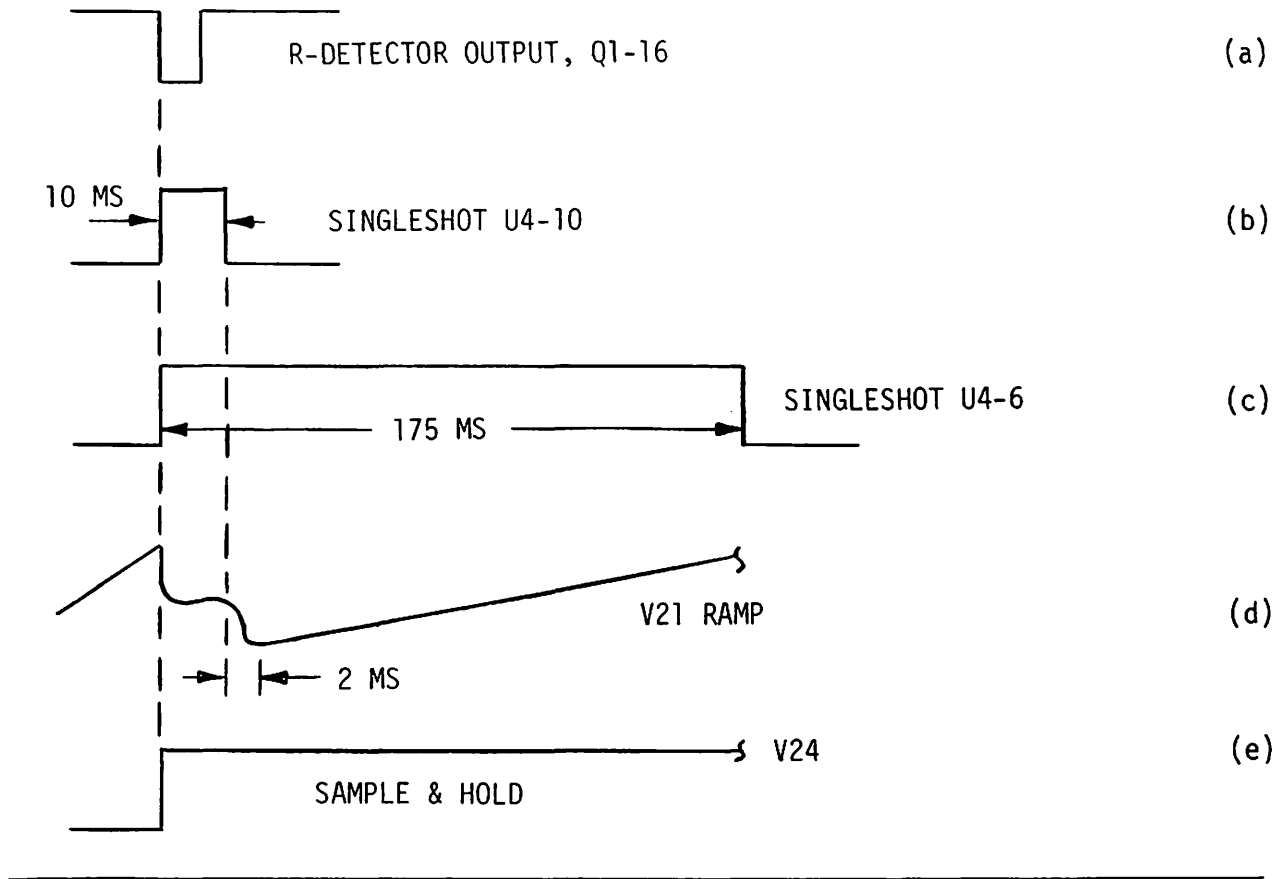

FIGURE 3-7. RATE COUNT TIMING

### 3-7. Rate Board Circuitry (continued)

#### E. Rate Measurement (continued)

In the second half of the history, 120 BPM is assumed. Now at the end of each ramp, charge flows from C24 to C21. But again equilibrium is quickly attained. At the time of the radical change from 60 to 120 BPM, the C24 voltage step illustrates the quick reaction of the weighted sampling technique employed.

- F. Rate Alarm (Systole Sound). One use of the weighted average voltage appearing across C24 is as an input to rate alarm comparators. These determine whether the heart rate, as evidenced by this voltage, is within a selected range of beats per minute. If the BPM value is too high or too low, the comparators cause a steady audio signal to be applied to a loudspeaker, DS1.

The comparators employ difference amplifiers U11 and U12. The C24 voltage is applied to the inverting input of both units. Reference voltage levels are established for the non-inverting inputs by connecting J1-2 and J1-9 respectively through operator-selectable resistances to ground. The operator selects these resistance values by means of two nine-position switches on the display board.

If the C24 voltage sample applied to U11 and U12 is higher than the high reference applied to U11, pin 3 (corresponding to a low heart rate alarm limit) or is lower than the low reference applied to U12, pin 3 (high rate limit), the collector of Q6 will transition from one's level (+5 volts) to zero's level. This alarm signal, applied to U10, pin 2, enables the systole sound oscillator. The resulting 2KHz square wave is applied through R60 and CR16 to the base of transistor Q5, which provides the drive current for the speaker DS1. During non-alarm conditions, systole beeping (U10, pin 5 high), the 2KHz signal is also applied through U10 to base of Q9. The collector of Q9 is connected through P1-7 to a shunting audio control (QRS VOL) on the front panel, thus providing variable control of the systole volume. During alarm conditions (U10, pin 5 low) U10, pin 6 output goes high causing Q9 to turn off, thus providing a continuous full volume alarm beep.

CR18 provides a hysteresis effect for comparator U12 after a high-rate alarm has been sustained. With the signal voltage at U12, pin 2 too low, U12, pin 6, comparator output switches to high, turning on Q6. The resulting current through CR18 and R57 raises the original non-inverting input slightly, tending to stabilize the comparator alarm output, even if the actual C24 sample magnitude subsequently varies slightly around the high limit. In comparator U11, diode CR11 offers similar hysteresis for the low limit.

3-7. Rate Board Circuitry (continued)

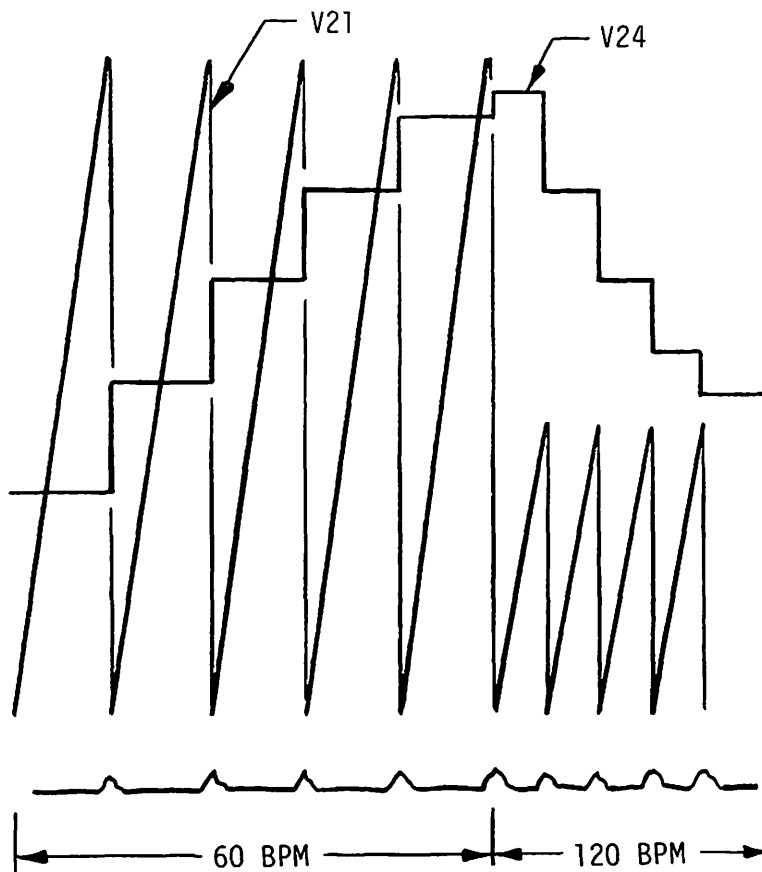

FIGURE 3-8. BEAT PERIOD SENSING, SAMPLING AND WEIGHTED AVERAGE

- G. Rate Display. As its second function, the voltage across C24 serves to inversely control the duration of a gating period for accumulating clock counts in a three-digit binary counter, U6. The count is thus made to measure the heart rate in BPM.

The counter counts in continuous cycles from 0 to 1,000, with each cycle ending with reset to zero. The clock pulses being counted are produced by a free-running square-wave generator whose output is U7, pin 11. The clock frequency is 285 Hz. Each cycle of counting from 0 to 1000 thus takes 3.5 seconds. Subsequent to the first zero count reset experienced by the counter after a given R-wave has been detected, the output register of the counter must be constrained to latch in the accumulating count at an instant such that the number of milliseconds elapsed since zero count equals the heart rate in BPM. That gating period in milliseconds,  $t$ , is adjusted during calibration against a known BPM and is to be proportional to the reciprocal of the voltage across C24 (i.e.  $t=k/V24$ ). The rationale for that equation follows:

### 3-7. Rate Board Circuitry (continued)

#### G. Rate Display (continued)

$$V_{24} = \frac{Q_{24}}{C_{24}}$$

$Q_{24} = iT$ , where  $i$  is the  $Q_4$  constant current, and  $T$  is the weighted average period between heartbeats.

$\therefore V_{24} = kT = k/B$ , where  $B$  is heart rate in BPM

or  $B = k/V_{24}$

The time gate starts, Figure 3-7(f), when a pulse appears at the counter overflow terminal, U6, pin 14. This pulse occurs when the count, having reached 1000, reverts to zero. The U6, pin 14 output causes the U7 flip-flop to transition. The resulting low at U7, pin 8 (Figure 3-7(g) acts as a control signal to U5c. That gate then opens its connection between pins 9 and 8. Till now, that connection had effectively prevented chargeup of C25. Now C25 and R52, R53, by virtue of their connection to U14, pin 2, cause U14 to integrate the stored signal  $V_{24}$  present at U14, pin 3. That is to say, C25 starts to charge at a constant rate. As in Figure 3-7(h) the output at U14, pin 6, climbs from its initial level of 1.66 volts to a final level of 3.33 volts. The speed of climb is directly proportional to the magnitude of  $V_{24}$  and inversely proportional to the RC constant of C25 and  $R53 + R52$ . Variable pot R52 is adjusted so that for a given  $V_{24}$  and corresponding heart rate of absolute value  $B$  the U14, pin 6 output climb from 1.66 to 3.33 volts takes  $B \times 3.5$  mSec.

As soon as the U14 output does reach and minutely exceed 3.33 volts, the inverting input to U8, pin 6 exceeds the 3.33 non-inverting input. The result is a zero-level output at U8, pin 7. Up to that moment, the gating flip-flop has had its U7, pin 9 and U7, pin 10 pins at a high's level. This has held U7, pin 8 low and kept switch U5, pins 9, 8 open. Now, however, the transition at U8, pin 7, causes the flip-flop to transition. The accompanying change to a high at U7, pin 8, closes switch connection U5, pins 9 and 8 and shorts capacitor C25 back to 1.66 volt level. Simultaneously, per Figure 3-7(i), the flip-flop channels a low to U6, pin 10, the latch enable of the counter. This enable causes the number  $B$  which has at that instant accumulated in the counter to be latched into the U6 output register. From U6, that number, having been converted there to binary-coded-decimal form, is dispatched in binary groups through pins 9, 7, 6, 5. Those pins correspond respectively to the 1, 2, 4 and 8 constituents of the decimal digit being transmitted. A pulse appearing on digit select pin 2, 1, or 15 indicates that the decimal digit defined at that moment by the binary number on pins 9, 7, 6, 5 is in the unit's or tens or hundreds place respectively. As indicated in the timing diagram, the transmission of the number latched by the counter takes 10.5 ms. The 3-digit decimal number is displayed on the display board.



### 3-7. Rate Board Circuitry (Continued)

#### G. Rate Display (Continued)

With no systole being sensed, an output is produced at J1-11 which blanks the BPM digital display. Concurrently, the rate alarm sounds if a low alarm is set. The cause of no systole input may be the placement of the patient lead selector to the STD position. Regardless of cause, the effect is to prolong the charging of C21 until finally the voltage across it blocks further collector current through Q4. Up till then, because of the ohmic drop through R45, R46, the voltage at op amp inverting input U8, pin 9 has been 3.33 volts. At the non-inverting input, U8, pin 10, the voltage has likewise been 3.33 volts. The U8, pin 8 output has been set by the voltage at Q4 emitter minus the voltage drop through the emitter-base junction and R4 at  $\sim 2.7V$ . Now, however, pin 8 of U8 swings towards 0 volts. When it reaches 1.66 volts, pin 1 of U8 goes high causing two things to happen. One, it is inverted at U9, pin 8 and is transmitted as a low through J1-11 to the display board, where it extinguishes the digital display of heart rate. Two, it constitutes a control signal to U5d, causing that gate to connect its terminal 11 to terminal 10. This path charges C24 to 3.33 volts, which condition causes the inverting input at U11 (the low rate alarm comparator) to exceed any selectable reference voltage at the non-inverting input. The U11 output goes low and actuates the alarm.

3-8. No-Fade Board Circuitry. The no-fade circuits sample the amplified ECG signal every 5.125 milliseconds and during a given sample period: (a) convert the signal amplitude in evidence at that moment to a binary number, (b) store that number in a solid-state memory along with 1023 samples similarly obtained and stored during the 1023 preceding sampling periods, (c) extract alternate numbers from memory sequentially and convert them in succession to analog voltage form for application to the vertical amplifier of the CRT, and (d) generate a sawtooth ramp voltage which, applied to the CRT horizontal amplifier, will create a time base for display of the analog output.

The no-fade action arises as follows: The horizontal sweep is gated for every fourth sample. It, therefore, has a repetition rate of approximately 50 Hz. Inasmuch as the reconstituted ECG analog signal is made up of 1024 adjoining segments, each representing a sample of 5.12 ms duration, it portrays a history of about 5 seconds. That is to say, if fully traced on the CRT, it would show heart activity from a time starting 5 seconds ago up to the present instant. The horizontal sweep rate is sufficiently fast that none of this 5 sec. interval exhibits any fading.

In order that the display may show a real-time progression of ECG events, referred to the constantly updated present instant, the memory addressing rate and sampling rate normally differ by one part in 1024.

### 3-8. No-Fade Board Circuitry (continued)

As a result, the analog segment displayed on the righthand side of the CRT, namely the segment representing the present instantaneous level of the ECG signal, is, as time progresses, shifted stepwise to the left and successively replaced on the right by more up-to-date segments. The collective result of such lateral stepping is that all waveforms on the screen are seen to move to the left until they disappear off screen, their place being taken by progressive more recent waveforms on the right.

Actuating an operator control labeled FREEZE, however, halts the lateral movement of the CRT display. It does so by dropping the ECG sampling rate by 1 part in 1025, causing the sampling and memory addressing rates to equalize. Thereafter, while the FREEZE mode remains selected, no update or motion of the original CRT display occurs.

A supplementary circuit on the no-fade board senses the effective vertical movement of the CRT display-painting beam. To the degree that the vertical movement exceeds a reference level, the circuit causes display intensification, thereby providing for overall uniformity of the visual trace with minimum power expenditure. Another circuit introduces a vertical marker at a pre-selected point on the R-wave portions of the displayed waveform.

The no-fade circuit functions are discussed in conjunction with Figures 3-9 and 3-10. The dashed blocks in Figure 3-9 enclose functional groupings of circuit elements. The block titles, when referred to in text, are initial-capitalized.

A. Analog to Digital Conversion. The ECG signal, having been raised in level in the preamplifier and amplifier stages, is channeled into no-fade board as signal ECG IN. There, as the waveform whose instantaneous amplitude is to be evaluated, it is applied to difference amplifier U13 in a comparator circuit in the Analog/Digital Converter. The other input to U13 is a reference staircase voltage derived as discussed in the following paragraph.

A 400-kHz oscillator provides a master square wave output which, after inversion in a Schmidt trigger, U9b in Chip Select Logic, serves to clock two free-running three-module synchronous counters: one the Address Counter consisting of modules U6b, U7a, and U7b; the other the sampling Cycle Counter consisting of U6a, U5a, and U5b. The Address Counter outputs a constantly cycling set of binary numbers from 1 through 1024, each number specifying the location of one word to be written into or read out from a Random Access Memory consisting of two 4-bit 1024-word RAM modules in parallel, U1 and U2. During a normal sampling period the Cycle Counter outputs a set of numbers from 1 through 2050, with 2048 appearing as a high at U5b-Q4. The 8 most significant bits of numbers 8 through 2047 are applied to resistance network RN1 in the A/D Converter.

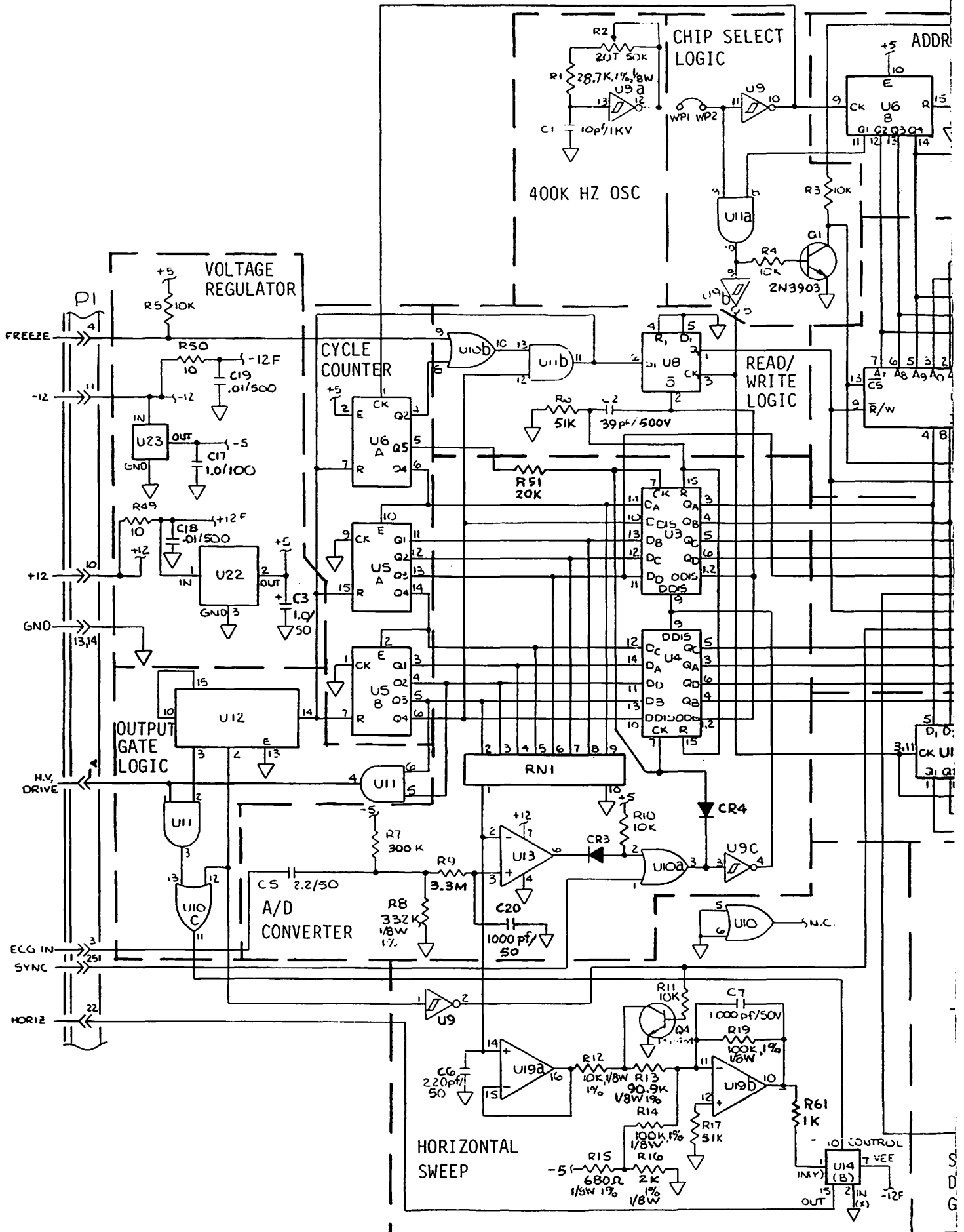
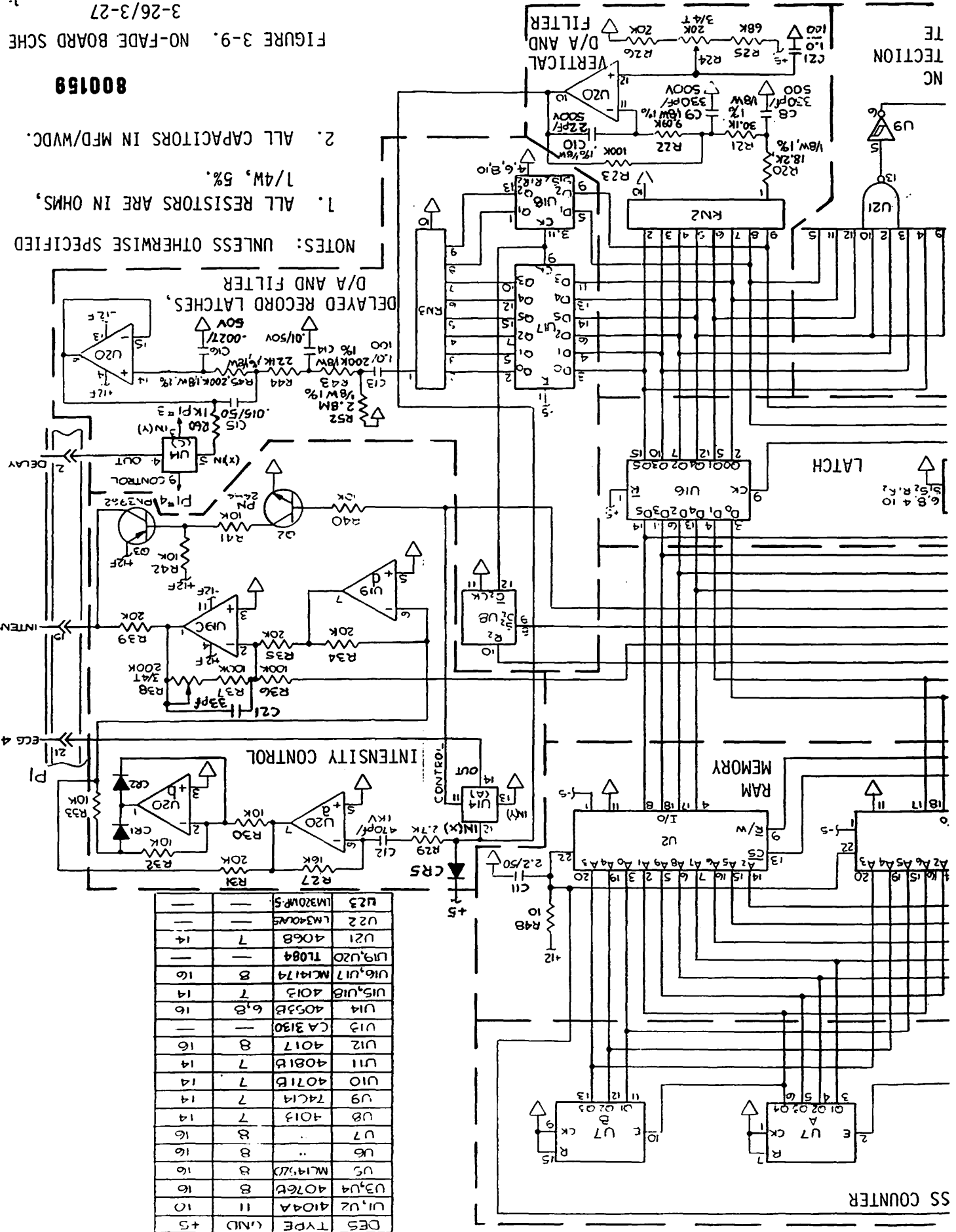

FIGURE 3-9. NO-FADE BOARD SCHE

800159

1. ALL RESISTORS ARE IN OHMS, 1/4W, 5%.
  2. ALL CAPACITORS IN MFD/MVDC.
- NOTES: UNLESS OTHERWISE SPECIFIED



DES TYPE	QND	+5
U1, U2	4104A	11
U3, U4	4076B	8
U5	ML1472J	8
U6	..	8
U7	..	8
U8	4013	7
U9	74C14	7
U10	4071B	7
U11	4081B	7
U12	4017	8
U13	CA3130	..
U14	4053B	6, 8
U15, U18	4013	7
U16, U17	MC14179	8
U19, U20	TL084	..
U21	4068	7
U22	LM340MS	..
U23	LM320P5	..

TE SECTION NC

SS COUNTER

### 3-8. No-Fade Circuitry (continued)

#### A. Analog to Digital Conversion (continued)

When the resulting voltage staircase output from RN1 to U13 increases to a level equaling that of the ECG IN signal to U13, the U13 output switches from high to low. Up to that instant, the increasing numbers being generated in the sample counter have been successively shifted into registers U3 and U4. As soon as U13 output goes low, however, so does gate U10a output. After output inversion in U9c, a logic 1 appears at pins 9 of U3 and U4, disabling further input to those units so that they register no subsequent higher number during the rest of the current cycle from 1 to 2050. The digital word (i.e., number) thus latched into U3 and U4 corresponds to the analog ECG IN signal and the analog-to-digital conversion for the present sample is complete. The clock pulses counted by the Cycle Counter in the sample period having been 2050 and the clock frequency 400 kHz, the sample event has lasted  $2050/4 \times 10^5$  seconds, or 5.125 millisecc.

- B. Write-In to Memory. When the cycle counter tally mounts to number 2050, the counter outputs to U10b and U11b in Read/Write Logic go high. As a result, AND gate U11b produces a logic 1 which, channeled to pins R in the cycle counter, initiate resetting of that counter to zero, ready for the next 1-2050 cycle. Meanwhile, the same logic 1 from U11b serves as a Set input into flip-flop U8. Hence the Q output of U8 goes high, constituting a write command to the RAM. The simultaneous write signal complement in the form of the  $\bar{Q}$  output from U8 serves to release for write-in to the RAM the data latched in U3 and U4 during the sampling period just ending. The actual RAM write-in occurs as a result of the upcoming chip select pulse.

In order to save power, the chip select pulse frequency is half that of the clock (200 kHz as opposed to 400 kHz). The halving is accomplished in U11a in the Chip Select Logic. This gate AND's an input from the 400-kHz master oscillator and a 200-kHz input from the least significant bit port of the Address Counter. The 200 kHz pulse output is multiple purpose: (a) it gates transistor Q1, whose resultant output enables the RAM's, (b) it provides a clock input to U8 so that after the U8 Write output command has caused one word to be written into one address the command reverts to Read, allowing the full 1024-word RAM contents to be read out during the next enabled sampling period.

### 3-8. No-Fade Circuitry (Continued)

- C. Full Memory Time Representation. Writing in of the RAM's full capacity of 1024 words represents the recording of ECG events occurring over a period of 5.248 seconds. The following computation of that 5.248 seconds promotes understanding of the circuits involved.

Each sampling event involves the accumulation of 2050 binary ones on the cycle counter. Each count takes one clock period,  $1/400,000$  sec. Therefore a sample takes  $2050/400,000$  sec. The RAM fills upon accepting 1024 such samples. Thus a full RAM represents a time period of:

$$1024 \times 2.05/400 \text{ sec.} = 5.248 \text{ sec.}$$

- D. Read-Out From Memory. After a given sample is written-in to the RAM, lodging in the address most recently generated in the Address Counter, the Write signal from U8 inverts as explained earlier, thus becoming a Read signal for the duration of the next sampling period in the A/D Converter. During that period the full cycle of 1024 is generated sequentially in the Address Counter, as the result of a counter receipt of 2048 clock pulses, at 400 kHz clock rate. Meanwhile as discussed earlier the Q1 output is enabling the RAM at 200 kHz rate. Therefore during the next period, the RAM are sequenced out into the storage registers U15 and U16 in the RAM Output Latch. Each word is successively latched into the registers by a pulse applied to their clock inputs, arriving coincident with the trailing edge of the chip select pulse from U9b. For each word latched, the outputs of U15 and U16 are then summed in resistance network RN2 in the Vertical Deflection D/A Converter. After smoothing in a filter stage there, the 1024 successive voltage steps (analog segment) are sequentially channeled through a gate (discussed later) in the Intensity Control Circuit and sent off-board as a signal ECG OUT for application to the vertical amplifier of the CRT.
- E. ECG Freeze. Three facts are clarified by Figure 3-10, namely: (a) that each new sample written into the RAM occupies a memory address previously held by the oldest stored sample of the ECG; (b) that the newest sample read out from the RAM is displayed on the right hand edge of the CRT; and (c) the displayed ECG moves from right to left.

These results occur because a sampling takes a time interval equal to 2050 clock periods to accomplish, as opposed to a RAM read-out cycle, which takes 2048 clock periods.

In the Figure 3-10, the sawteeth represent the generation of three successive voltage ramps out of RN1, and therefore three sampling events. The abscissa denotes time from  $t(0)$ . The first ramp is completed after 2050 clock counts. In that time the RAM address counter has cycled from 1 to 1024 and back to 1. Accordingly when

### 3-8. No-Fade Board Circuitry (continued)

#### E. ECG Freeze (continued)

sample 1 is written in to the RAM it lodges in address 1. Inasmuch as the CRT horizontal sweep is initiated when the RNI output reflects 2050 clock counts, each sawtooth also represents one left to right sweep. Accordingly when sample one is displayed it appears initially on the righthand edge of the CRT.

In sawtooth two, sample two, is written into the RAM when the address counter reaches count two. New sample 2 therefore erases the word formerly stored at address 2 and representing the oldest prior sample, which in read cycle 2 was displayed on the extreme left edge of the CRT (actually offscreen). During read period 3 new sample two will be displayed on the extreme right edge, and the immediately preceding sample will have moved one slot to the left. And so with time each given address being read out two clock counts earlier per sweep cycle, each sample moves left until it appears on the extreme left edge of the CRT. That address then is selected at the end of the next sampling period as the repository for the newest digital word, which thus takes the place of the oldest digital word.

The leftward movement of the ECG display can be halted and its resultant disappearance offscreen left after some five seconds can be prevented by pressing the FREEZE button on the control panel. This action channels a logic 1 input to OR gate U10b in the read/write logic. Thus at a cycle counter output representing number 2048 AND gate U11b has two high inputs, initiating a write signal to the RAM and resetting the cycle counter. Consequently, while the FREEZE switch remains actuated, both the address and the cycle counter count in 1 clock step from 1 clock pulse through 2048, no new information is written in or displayed, and with the horizontal sweep period now reflecting 2048 clock pulse periods and exactly matching the RAM readout cycle period, the selected ECG display remains fixed in location and shape.

- F. Circuit Adjustments. The main clock frequency for the no-fade board is provided by an oscillator comprised of a Schmidt trigger (U9a) and a time-constant circuit composed of R1, R2, and C1. Adjustment of the R2 potentiometer trims the frequency to 400 kHz.
- G. Defibrillation Sync Display. When the synchronized defibrillation mode is selected and the R-wave detector produces defibrillation sync pulses, each pulse is channeled to the no-fade board as signal SYNC. Board circuits then cause an intensified spike marker to be superimposed on the ECG at points corresponding to each time a sync pulse was generated, thus indicating when defibrillation was suitable and enabled.

3-8. No-Fade Board Circuitry (continued)

G. Defibrillation Sync Display (continued)

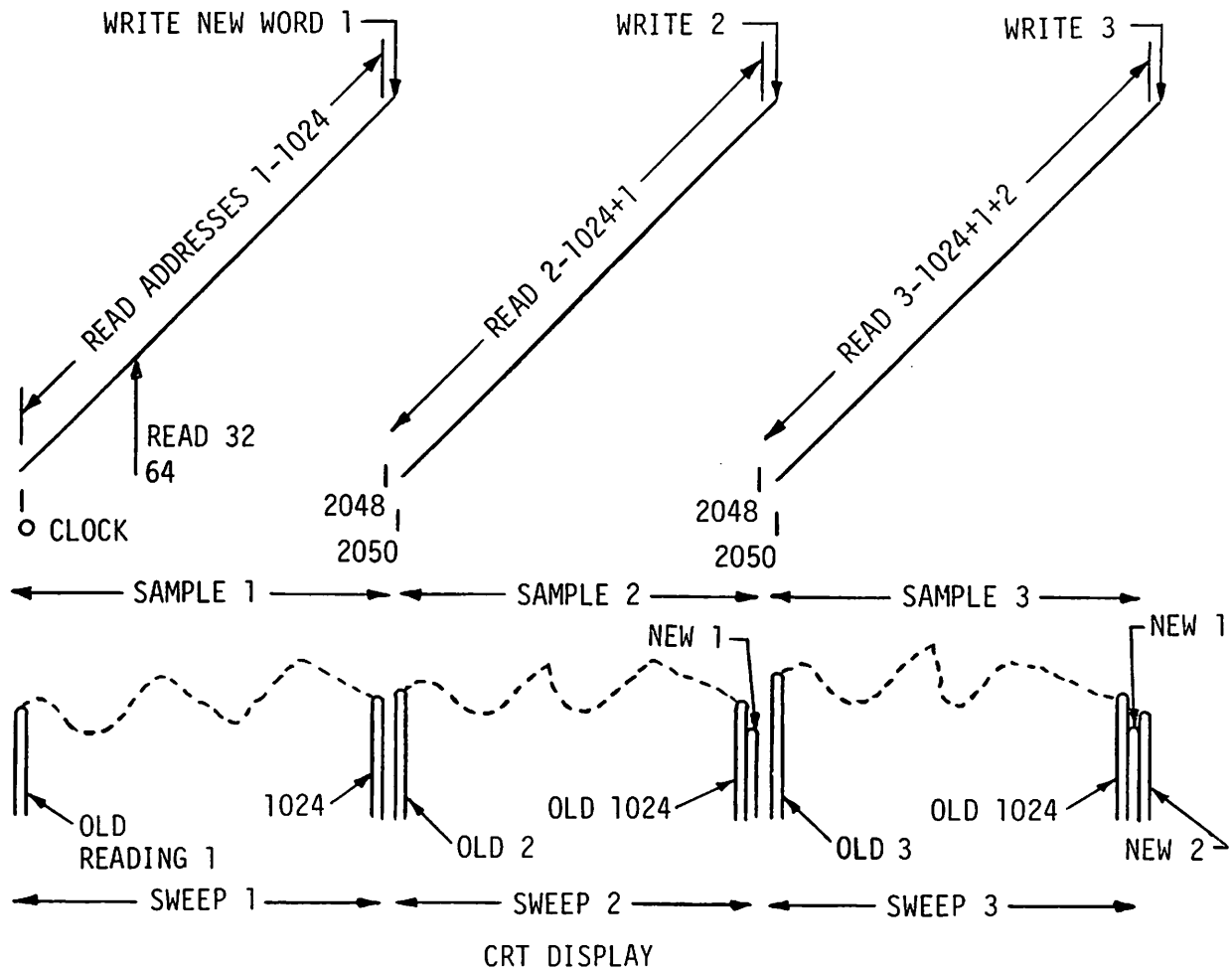

FIGURE 3-10. CARDIOSCOPE (CRT) DISPLAY

Initiating such a marker, the SYNC pulse (a logic high) is inputted to OR gate U10a in the A/D converter. As a result any low appearing in the comparator input to U10a is overridden for the duration of the SYNC pulse. Thus registers U3 and U4 are forced to accept an uninterrupted progression of binary numbers from the Cycle Counter until register capacity is reached, namely 255 counts (representing decimal numbers 16 through 2048).



### 3-8. No-Fade Board Circuitry (continued)

#### G. Defibrillation Sync Display (continued)

Consequently, when the current ECG sampling period ends and the next chip enable pulse arrives, the eight-bit number written into memory and read-out into latches U15 and U16 is all ones. The latch all-one's output to AND gate U21 in the Sync Detection Gate produces a U21 high signal to the Intensity Control circuit. That circuit then causes intensification of the CRT beam throughout the SYNC pulse period. The readout of apparent ECG amplitude being all ones during that pulse, the CRT trace is concurrently deflected to the top of the screen. The combined effect is a brightened vertical blip.

- H. Intensity Control. This circuit saves beam power and enforces uniformity of waveform brightness. In part, the power requirement is reduced by blanking CRT anode voltage during three of every four readout cycles from the RAM memory. Brightness uniformity and further power savings are promoted by varying beam intensity in direct proportion to the speed of trace vertical travel.

As discussed earlier, the 50 Hz signal to U14a blocks ECG output for three samples out of four. In addition, channeled to Q2, it causes blanking of beam intensity while the ECG output is blocked. That is to say, the gating off signal, appearing as an input high to Q2, is inverted as a low to Q3 base, causing Q3 conduction that switches +12 volts to J1-J5, as output signal INTENS to the CRT anode circuit. This shuts off the beam accelerating voltage.

On the other hand, during the one read-out in four when ECG OUT is gated on, the slope of the ECG signal serves as the basis for controlling display intensity. The slope is sensed by differentiating the signal in C12 and processing the result in operational amplifiers U20a and b and U19d to produce an absolute value of the slope at U19d, pin 7. That signal is inverted and amplified at U19c. The output, signal INTENS, is a negative-going full-wave rectification of the slope of the vertical deflection signal. This produces increased intensity on the faster traveling portions of the ECG, particularly so on the steepest slopes, experienced on the R wave portion. In consequence, a relatively low average beam intensity is needed, reducing power requirement and the chance of burning the baseline into the CRT.

- I. Delayed Record. In order to give the operator adequate reaction time to record from memory an interesting ECG before that waveform is erased, a Delay Record Circuit is provided.

When during any sampling period the cycle counter reaches a count of 32, terminal R2 of flip-flop U8 in the delay record circuit receives a pulse from the counter. The resulting  $\bar{Q}$  output from U8 causes registers U17 and U18 to latch the binary word then being read from memory. This word is thus applied as a binary

### 3-8. No-Fade Board Circuitry (continued)

#### I. Delayed Record (continued)

number to resistance network RN3, summed there to analog voltage form, and filtered and amplified. It is then conveyed through normally conducting FREEZE gate U14c and outputted to the recorder as signal DELAYED RECORD. Figure 3-10 illustrates the delay mechanism.

Each ramp corresponds to an ECG A/D converter sampling staircase produced by a cycle counter count from 1 through 2050. Each sample therefore takes  $2050/400,000 \text{ sec} = 5.125 \text{ ms}$ . During such a period the memory is serially scanned through its 1024 addresses and then back to the original address.

For simplicity, in sketched ramp 1 the address scan is assumed to start at 1. Therefore it sequences from 1 through 1024, then back to 1. During that ramp, the word read-out from RAM at clock count 64 and constituting the first sample input to the recorder will come from address 32. This address represents a sample taken 993 sample periods earlier than the present sample, which will be inserted into address 1 at the end of the period occupied by ramp 1. Similarly, during ramp 2, the address will cycle from 2 through 1024, back to 1. At clock count 64, the word stored at address 33 will be conveyed to the recorder. As in ramp 1, this word will represent the sample taken 993 samples earlier than the newest sample, which will be lodged in address 2.

Thus the recorder constantly senses and records the event that occurred  $993 \times 5.125 \text{ ms}$  earlier, that is to say, the delay is 5.09 seconds.

- J. Blanking Control. In order to save power, only one of every four sweeps is gated to the CRT deflection amplifiers. This blanking is effected in the Output Gate Logic, Horizontal Sweep Circuit and Intensity Control Circuit.

A 200 Hz square-wave from the Cycle Counter is inputted to the divide-by-four counter U12. The U12, pin 2 output (50 Hz) is applied through OR gate U10c to control the analog gate U14b in the Horizontal Sweep Circuit. One sweep out of four is thereby conducted through U14b to J1, pin 22 as signal HORIZ to the oscilloscope. The U12, pin 2 output is also applied to control the analog gate U14a. As a result one ECG sample out of four is conducted through U14a to J1, pin 21 as signal ECG OUT to the oscilloscope.

- K. Horizontal Sweep Circuit. The ramp from the A/D converter is used to generate the horizontal sweep. Inasmuch as the ramp in normal operation (freeze mode not selected) builds over a count from 0 to 2050 pulses from the 400-kHz clock, the normal sweep period is 5.125 millisecon. The ramp voltage over that time swings from 0 to 5 volts DC. This input to the Sweep Circuit is applied to buffering amplifier U19a, summed with -2.5 volts and inverted in U19b to yield a sawtooth swing from +2.5 to -2.5 volts. This output is gated through U14b.

3-9. Recorder Board Circuitry. The recorder board contains the control circuits for stylus heating, pen drive, and paper drive.

Heating of the recorder stylus, required for the heat-sensitive paper, is provided by the current output from P2-3. Control of that output is effected by the single pulse circuit associated with Q1 and by the U3 timer circuit.

Upon recorder turn-on, current charging C11 develops a Q1 base-to-emitter voltage that turns on Q1. Charging C11 takes about 3 seconds. For that period, therefore, Q1 collector voltage is low. That low, transmitted to timer U3, pin 4, reappears without delay at U3, pin 3. Applied to Q2 base, it turns that transistor on, conducting stylus heating current through P2-3 for an uninterrupted 3 seconds for quick initial warmup.

When C11 is fully charged, Q1 turns off and Q1 collector goes fixed high. Thereafter U3, pin 3 output alternates high and low under the command of the timer U3. The duty cycle (U3, pin 3 output low) depends on the setting of resistor R27. It varies from about 47% (R27=0) to about 19% (R27=50K). The duration of U3, pin 3 cyclic low is 0.104 msec. The duration of U3, pin 3 cyclic high is adjustable (via R27) from 0.45 msec maximum to 0.11 msec minimum.

The paper drive circuit produces a steady DC current that advances the recorder paper at a fixed speed of 25 mm/sec. Zener CR1 maintains a 6-volt drop across itself so that its anode is regulated to -6 volts. The fraction of that voltage tapped by potentiometer R20 fixes the speed at 25 mm/sec. The inverted output at U1, pin 10 analog controls power amplifier Q3 to supply constant drive current through the motor commutator to the armature winding. Negative feedback to U1, pin 12 and from Q3 emitter counteracts motor frictional or inertial variations by maintaining constant voltage across the motor winding inductance.

The ECG signal, either real time or delayed, appears at J1-6 for amplification and application to the pen deflection motor. The first two amplifier stages provide high-frequency discrimination against noise on the input line. Op amp U2 furnishes the power amplification and as such is mounted on a heat sink to dissipate thermal energy. The drive output is applied to the two pen deflection windings in series, for deflection left or right depending on the signal polarity. The small third winding senses pen deflection velocity and sends a feedback signal to U2 to damp inertial overshoot. A bridge circuit including the main windings, R11 and R10, and feedback stage U1 is balanced via potentiometric pickoffs at R10 and R17, the former involving primarily adjustment for fidelity of square-wave representation, the latter primarily damping.

3-10. Rate Display Board Circuitry. The circuit of Figure 3-12 provides a lighted digital display of patient heart rate in beats per minute. It also provides a blink indication synchronous with each beat.

Four-bit binary coded-decimal numbers generated in the R-wave count circuit are channeled through J1 to pins 7, 1, 2 and 6 of BCD-to-seven segment decoder U1. These four pins correspond to decimal numbers 1, 2, 4 and 8 respectively. Transistor supply voltage is inputted at U1, pin 16. A signal low inputted through pin 4 of U1 blanks the display when the patient lead selector is placed on STD.

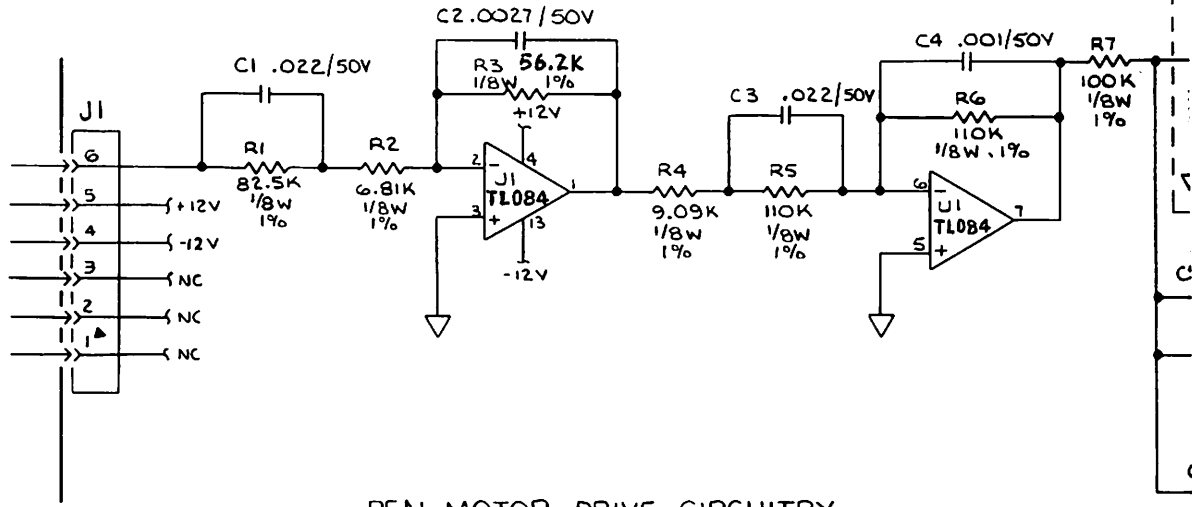

PEN MOTOR DRIVE CIRCUITRY

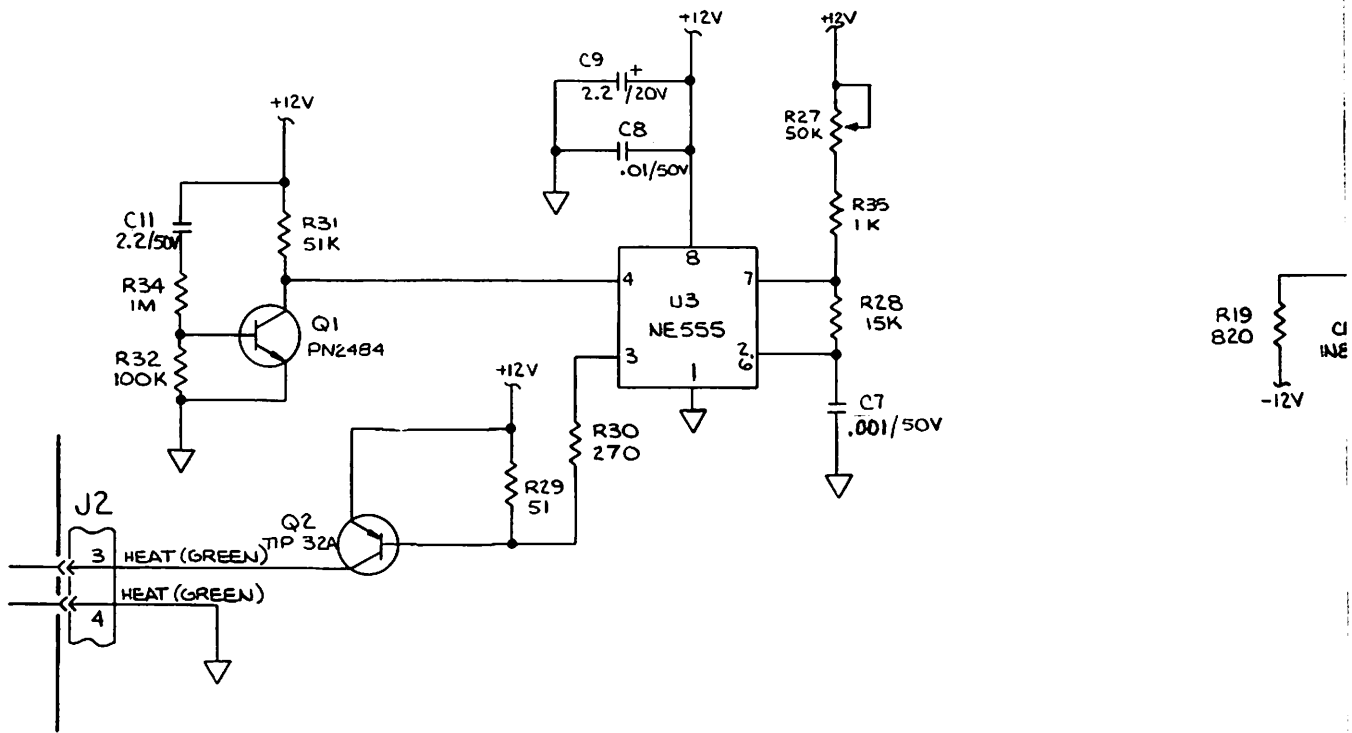

STYLUS HEAT CIRCUITRY

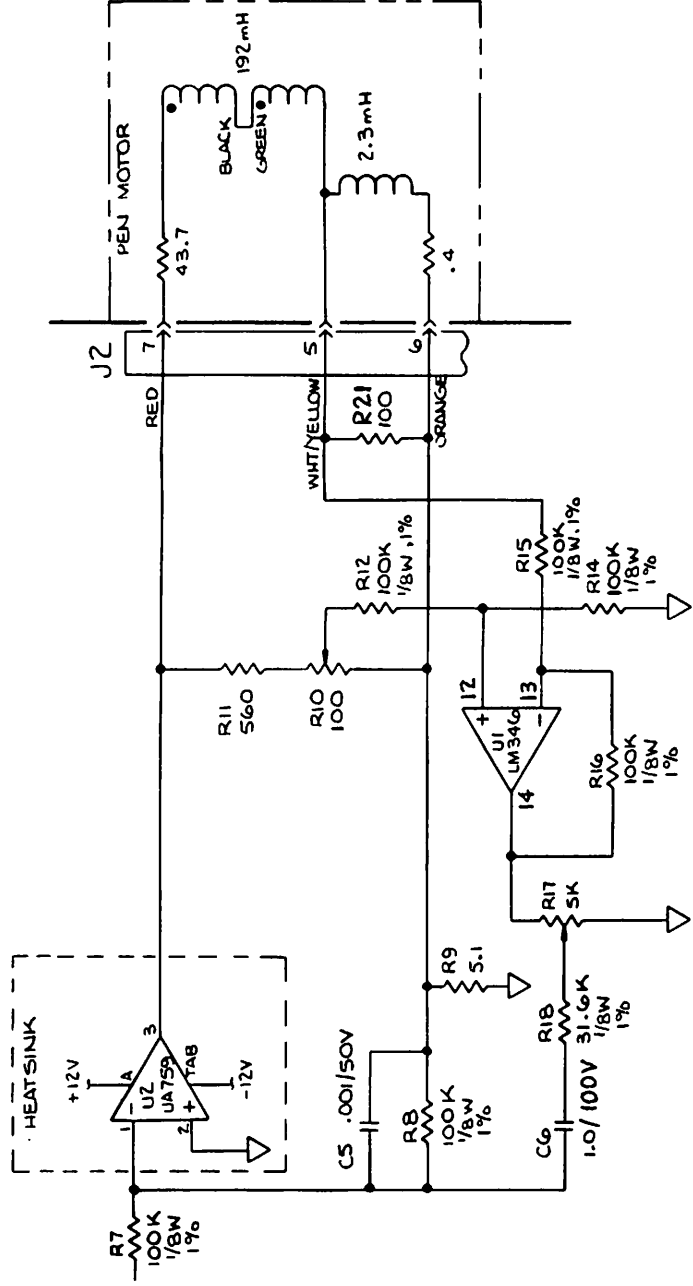

NOTES: UNLESS OTHERWISE SPECIFIED

1. ALL RESISTORS ARE IN OHMS, 1/4W, 5%.
2. ALL CAPACITORS IN MFD/WVDC.

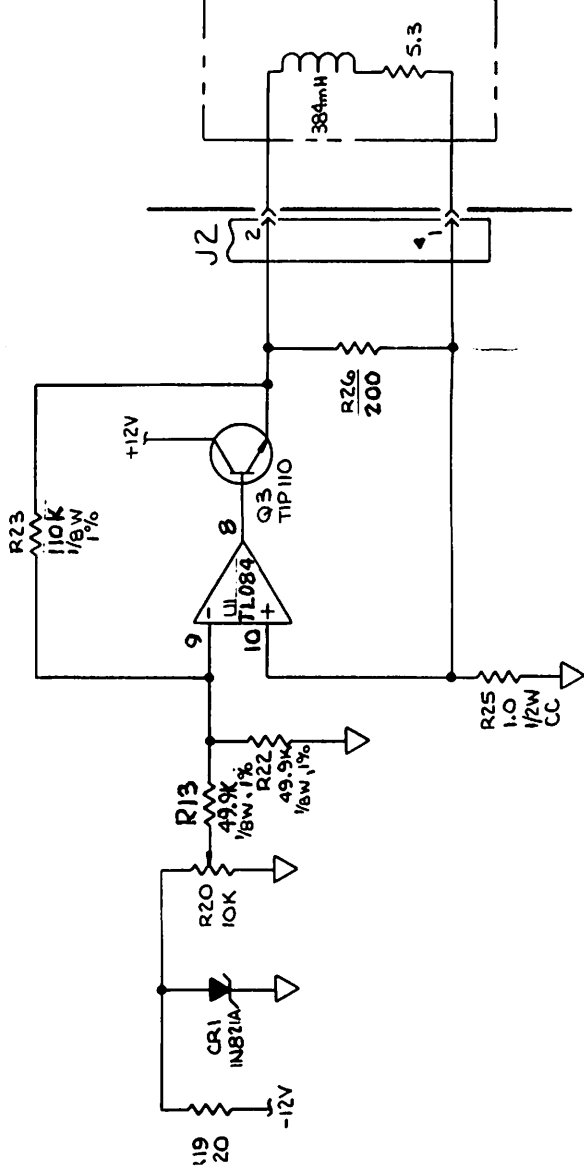

800033

PAPER MOTOR DRIVE CIRCUITRY

FIGURE 3-11. RECORDER BOARD SCHEMATIC

### 3-10. Rate Display Board Circuitry (continued)

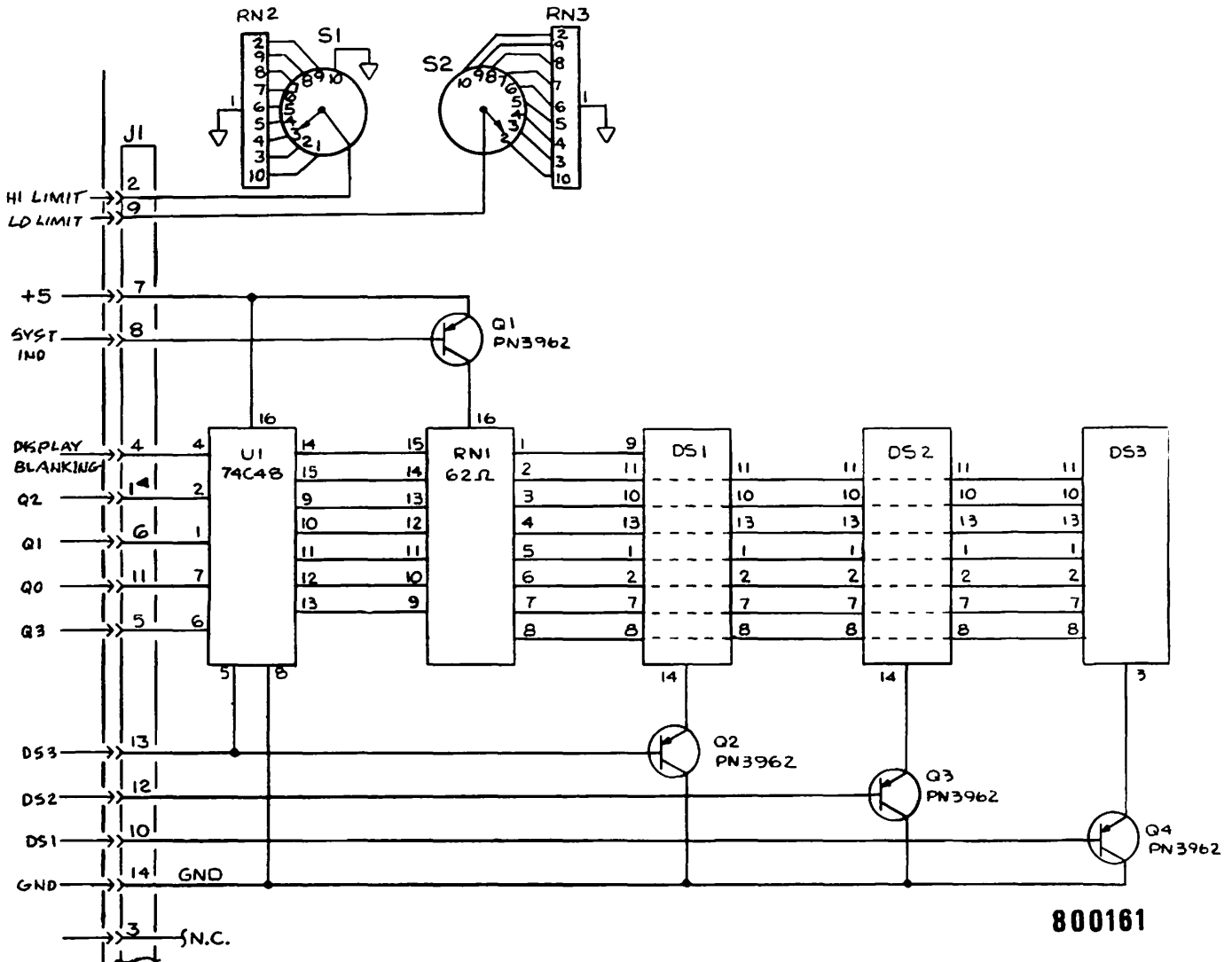

FIGURE 3-12. DISPLAY BOARD SCHEMATIC

The decoder outputs through pins 9-15. These pins go high in ten combinations, each combination representing a different digit in the range 0 through 9. A high at a given pin is transmitted through a series resistor in RN1 and thence to the anodes of three light-emitting diodes, one each in DS1, DS2 and DS3.

Each DS module contains seven such LED's, with each LED spatially arranged as one segment of a seven-segment figure  $\square$  array. The cathodes of all seven LED's are connected through module pins 14, 3 to the emitter of a transistor. When the anode of a given LED is connected to a U1 output high, and when simultaneously its cathode-connected transistor conducts by virtue of a pulse at the transistor base, that LED emits light. The result is the display of that one segment, as part of a display of some integer in the range 0 through 9.

Transistor Q4 controls the lighting of LED segments in DS3, which displays digits in the unit's place. Similarly Q3 controls DS2 digits displayed in the ten's place, while Q2 controls DS1 digits in the hundred's place.

### 3-10. Rate Display Board Circuitry (continued)

The three transistors, Q2, Q3, and Q4 are turned on successively by strobe inputs at J11, J10 and J9. The strobe signals originate in digital rate circuits on the rate board. The period between successive strobe pulses on any one line is 10.5 ms. The strobe duty cycle is 1/3; any given transistor is enabled for 3.5 ms, then disabled for the next 7 ms, during which time the other two transistors are sequentially enabled for 3.5 ms each. Eye persistence of vision allows all three digits selected for display in a given readout to appear steadily illuminated.

Heart beat pulses generated in the R-wave detector are conveyed through J1-12. Arrived at the base of transistor Q1, they cause +5 volts to be conducted through Q1, a resistor in RN1, and thence to the anode of a separate LED in DS1.

When DS1 is enabled through Q2 at strobe frequency, the separate LED emits light. The visual result in the front panel, adjacent to the digital display is a light blink during each successive heart beat.

Switch S1 and S2 select from differently valued resistances in RN2 and RN3 respectively, thereby setting the low and high limits respectively for heart beat rate comparators on the rate board.

### 3-11. Power Supply/Deflection Board Circuitry. As shown in Figure 3-13, the power supply/deflection board provides amplification for the horizontal and vertical deflection signals for the cardioscope (CRT) display, CRT high voltage supply and the main power supply for the module as follows:

- A. Cardioscope (CRT) Deflection Amplifiers. The horizontal sweep signal incoming at P1-22 ramps from -2.5 to +2.5 volts 50 times a second. Power op amp U7 amplifies that signal, to provide the current ramp to the CRT horizontal deflection coil externally connected between J1-1 and J1-2.

The fraction of the P1-22 signal applied to the non-inverting input, U7, pin 2, depends primarily on the calibrated setting of gain potentiometer R15. The fraction applied, however, varies slightly during each sweep because the resistance through CR17 and CR18 to ground depends on instantaneous signal strength. Diode CR17 conducts on the positive half of the ramp, CR18 on the negative. As diode current increases, diode resistance decreases. This effect improves the overall visual linearity of the sweep, compensating for screen curvature.

The sampled ECG wave appears at P1-21 for power amplification and application to the vertical deflection coils of the CRT. The re-constituted ECG signal represents a spectrum about 1000 greater in frequency than the original, inasmuch as the portrayed history covers about 5 seconds but is horizontally swept once each 5 milliseconds.





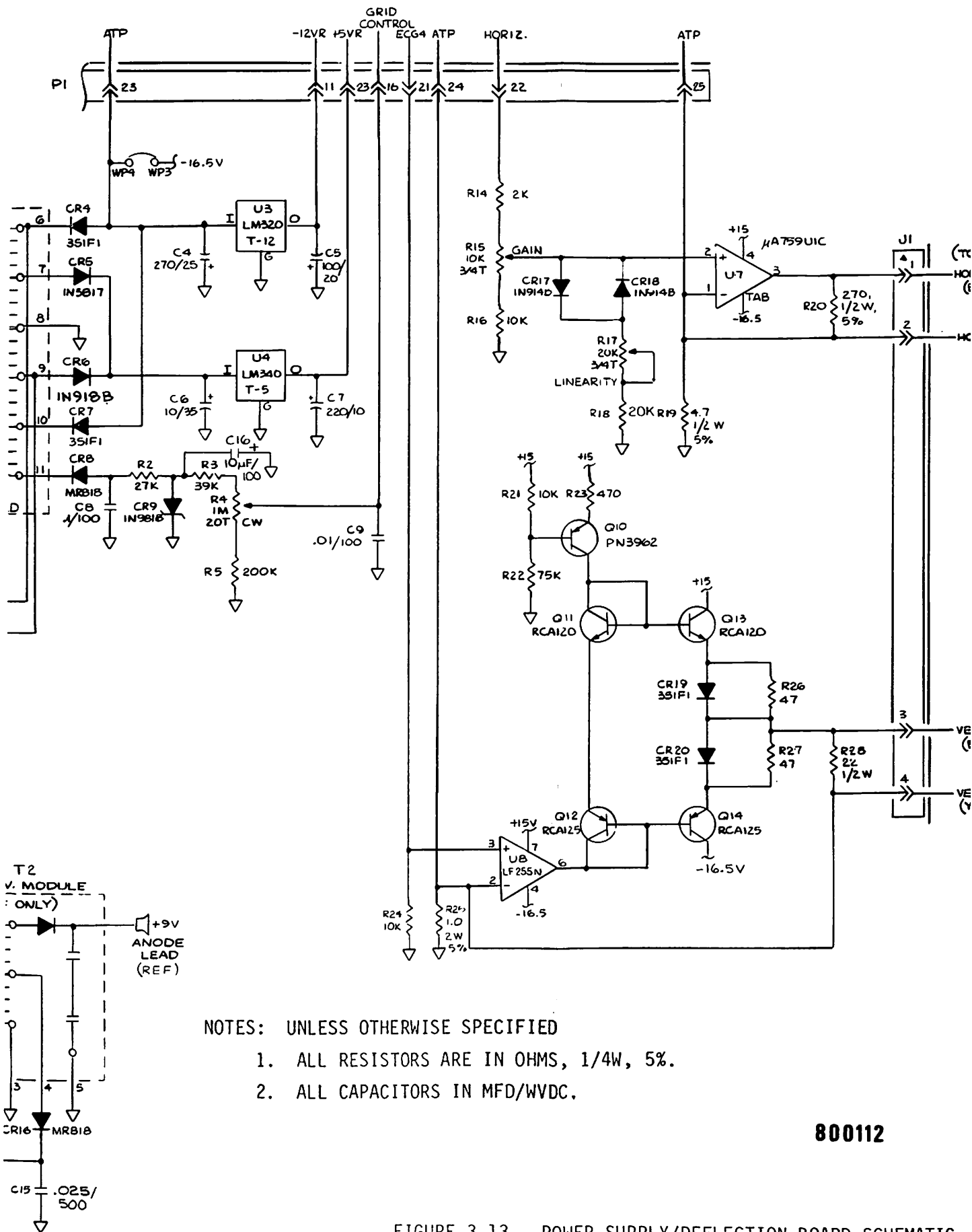

- NOTES: UNLESS OTHERWISE SPECIFIED
1. ALL RESISTORS ARE IN OHMS, 1/4W, 5%.
  2. ALL CAPACITORS IN MFD/WVDC.

800112

FIGURE 3-13. POWER SUPPLY/DEFLECTION BOARD SCHEMATIC

3-39/3-40

### 3-11. Power Supply/Deflection Board Circuitry (continued)

#### A. Cardioscope (CRT) Deflection Amplifiers (continued)

The amplified signal appearing on op amp output U8, pin 6 is converted to deflection coil current drive by a transistor network. Transistor Q10 provides a constant current source for base drive of Q13. In proportion to the magnitude of a positive output at U8, pin 6, conduction diminishes through Q11 and Q12 (which are connected as diodes). Accordingly Q14 is turned off and Q13 current is made proportionate to signal. With positive signal increase, current increases through R26, CR19 to J3. A negative output at U8, pin 6 increased Q12 current and turns off Q13, while increasing Q14 current proportionate to signal. With negative signal increase current increases from J3 through R27 and CR20.

#### B. High Voltage Supply. High voltage drive pulses, positive-going square-waves, generated on the no-fade board at a frequency of 200 Hz, arrive at the P1-1 of the power supply board.

On the negative going transition of the signal at P1-1, U6, pins 1 and 2 are driven low which causes U6, pins 8 and 11 to go high. As C13 charges through R10 and R11, the voltage on U6, pins 1 and 2 increases. When the threshold voltage of U6 is reached, U6, pins 8 and 11 go low and remains low until the next negative transition of the input. This is coupled to the base of Q9 causing it to conduct when pins 8 and 11 of U6 are high.

During the time Q9 is conducting, the current in the primary winding of T2 increases linearly storing energy in the core of T2. When Q9 is turned off, the secondary of T2 flies back to +9KV, and the energy stored in the core is released to the secondary.

Voltage on the secondary is dependent on the amount of energy stored in the core during each cycle i.e., on time of Q9. The secondary or anode voltage is adjusted by the potentiometer of R10.

The resulting high voltage positive swings at the top of the secondary are diode-rectified, smoothed by two capacitors in series to ground, and applied as anode voltage of 9KV in the monitor cathode ray tube. A lesser portion of the secondary voltage is topped, rectified in CR16, filtered in C15, regulated by R31, CR21, CR22 and applied to the CRT accelerating anode at +400 volt level.

#### C. +12 Volt Regulator. Zener diode CR12 causes the +14.4 volt input from the charger board to be dropped to 6.2 volts applied to the non-inverting terminal of op amp U5. Feeding back the output through to the inverting input (via emitter followers Q7, and Q8) locks the output at 12.1 volts. This potential is applied offboard via P1-10 as a voltage regulated supply elsewhere in the monitor. In addition, after being filtered, it forms the power supply for the T2 primary winding current.

### 3-11. Power Supply/Deflection Board Circuitry (continued)

D. Power Supply. Referring to Figure 3-13, the 13 volt regulated potential across zener diode CR1 is derived from the 14.4 volt charger input at P1-12. Amplifier U1a oscillates at 40KHz by virtue of RC feedback. Its squarewave output clocks D-type flipflop U2a, the result being that the flipflop Q and  $\bar{Q}$  terminals output complementary squarewaves of 20 kHz frequency. These waves are buffer amplified and applied pushpull to the paralleled gates of two sets of three high-current capacity VI40S-FET transistors. As a result, current driven by the +14.4 volt input flows in T1 primary winding, alternating in direction, first from center tap to terminal 1, then from center tap to terminal 3. With a given direction of flow, the inductive voltage developed across the full primary by virtue of auto transformer effect is twice the 14.4 volt input or essentially 30 volts. With reversal of flow direction, the full winding induction is again 30 volts, but of opposite polarity.

Preamplifier chopper drive is tapped off of the T1 secondary at T1-6 and T1-9, and distributed out through P1-19 and P1-20. The squarewave voltages at these points (with respect to chassis ground) are  $\pm 20$  volts and  $\pm 10$  volts respectively. Since these voltages are  $180^\circ$  out of phase with each other, the differential signal between P1-19 and P1-20 is 30 volts peak-to-peak at 20 kHz.

The voltage wave from primary center tap to end points, 30 volts p-p, is full wave rectified by CR10 and CR11 for use at 26 volt level in the anode voltage circuit.

On the T1 secondary winding terminals 6 and 10 alternately swing to 17 volts negative with respect to ground. By virtue of CR4 and CR7 alternate conduction, the -16.5 volts is applied to voltage regulator U3, which produces a -12 volt regulated output. Similarly, by virtue of CR5, CR6 alternate conduction +7.5 volts is applied to regulator U4, which provides the +5 volts regulated supply. On negative swings, CR3 conducts, so that zener CR9 maintains -62 volts across itself with respect to ground. A selected portion of this voltage is tapped to supply CRT grid bias.

For squarewave rectification, as T1 secondary winding, points 6, 7, 9, 10 and 11, alternately swing negative or positive with respect to center tap 8, diodes CR4, 5, 6, 7 and 8 alternately conduct, providing rectification.

The outputs of the rectifiers are filtered by C4, C6, C8 and in cases of the -12R and +5R voltages are series pass regulated by U3 and U4 respectively. The -10V to -60V output is regulated by zener diode CR9, adjusted by potentiometer R4 and filtered by C9.

(This page intentionally left blank)

- 3-12. Monitor Charger Board Circuitry. The charger board in the monitor module provides for (a) Rectification of line power as +15 volt source for module, (b) Battery trickle charging, (c) Automatic selection of battery as +15 volt source if AC power is interrupted, (d) Sensing of battery condition and charging status.

As indicated on Figure 3-14, when the module is plugged into a 115-volt line, the line is connected through fuse F2 on the charger board, and then to the power transformer, located on the module proper. Transformer secondary is applied across the diodes CR1, CR3, and CR4.

Rectification of one half the maximum potential appearing across the secondary and connection of the resulting +15 volts to output pin J1-1 involves diodes CR4 and 3, capacitor C1, and relay K1. Fuse F2 is slow-blow to accommodate the initial charging of C1.

Assume that initially the transformer secondary voltage swings so that J2-3 is at its maximum negative amplitude. With the center tap positive relative to J2-3, current to charge C1 flows through J2-1. The return path from the grounded plate of C1 is through CR3 to J2-3. A half cycle later, the maximum negative swing will be at J2-2. With the center tap now positive relative to J2-2, current flow to charge C1 will still be through J2-1. The return path from C1 will be via ground, CR4 and J2-2.

With C1 charged, relay K1 will have energized, pulling its wiper to the normally open contact. The +15 volts is thus outputted through fuse F1 to P1-9. That point is connected to the power switch on the front panel. Actuation of that switch connects the +15V to its points of application.

Trickle charging of the battery involves full secondary voltage and CR1 diode in halfwave rectification. The rectified output is passed through current-limiter R2 and on to the nickel cadmium battery, whose positive terminal is plugged into P1-7. When the battery is fully charged, the trickle charge through R2 is 150 mA.

While battery charge is occurring, the CR1 output pulls the emitter of Q1 positive (around 16 volts). The base being at 15V, Q1 switches on, channeling the +30V through R1, Q1, and a front panel LED connected to P1-6. The LED, labelled BATT CHG, accordingly lights whenever charging current flows.

When AC power is not available or is not selected, relay K1 de-energizes. As a result K1 wiper switches to the NC contact, thereby connecting battery output to P1-9. Moreover, with Q1 base and emitter now equipotential, Q1 is off and LED BATT CHG does not illuminate.

Battery condition is indicated by a front panel meter connected to P1-3. Zener diode CR2, whose anode is connected to the battery + terminal maintains a voltage of 12 volts across itself. If battery voltage drops to only slightly below that level, the meter current drops to near zero, causing the meter needle to fall into the red range.



### 3-13. DC DEFIBRILLATOR

The following paragraphs 3-14 through 3-16 provide the LIFEPAK 6 DC Defibrillator circuit description. The interconnect wiring diagram presented in Section VI provides the complete interconnection data for the subassemblies which comprises the LIFEPAK 6 DC Defibrillator.

### 3-14. Main Board Circuitry

The central function of main defibrillator board is to convert +12 volt input to high-voltage DC pulses and to control the application of these pulses. Entailed steps include power on-off control, provision of supply voltages, controls initialization, and active control. The aspects of active control are: (a) energy-storage capacitor shunt withdrawal; (b) high-voltage pulse timing; (c) stored energy level selection; (d) dumping of unwanted stored energy; (e) disconnection of ECG monitoring circuits; (f) discharge mode enabling (defibrillation of synchronized cardioversion); (g) status display; and (h) control of stored charge application to the patient. (See Figure 3-15).

- A. On-Off Control. The +12 volt input from the charger board to the main board appears at J3-3. The DC input path to terminal 1 of transformer T1 will eventually be completed when the coil of on-off relay K1 is energized. Initially, however, the path from K1 coil to ground is open because transistor U5a in that path is not conducting. Control of U5a is made via a front panel control and the K1 wiper bypass path involving transistor Q3.

In the quiescent state, Q3 is not conducting but maintains its emitter and base at the +12 volt input potential. The monostable flip-flop U1a Q output is high. The first depression of the POWER switch, a momentary switch on the defibrillator front panel, grounds J1-9, thus causing C10 to charge almost instantly to +12 volts. Figure 3-16 traces subsequent events.

The ground signal to U1a, pin 10 triggers U1a to its instable state, which lasts as long as the power switch is depressed, and then until C10 has discharged through 130K ohm (RN1-7 to 8) to about +6-volt level. During this period, the Q output (U1a, pin 12) is low, that turns on Q3.

While Q3 is on, its current charges C1 and C15 to full +12 volt level. Later when the K1 wiper closes, it will not switch a large charging current that would tend to degrade its contacts.

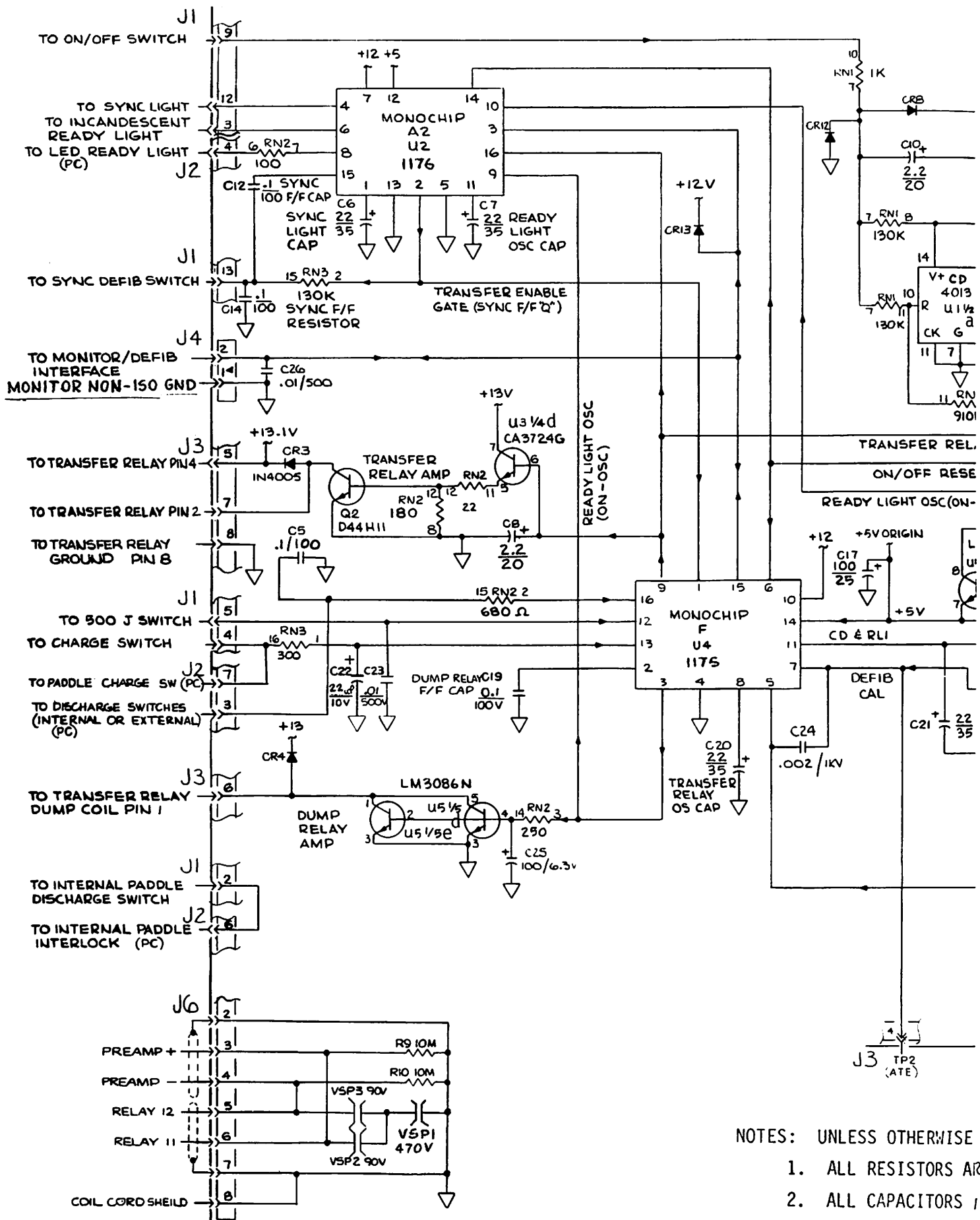

- NOTES: UNLESS OTHERWISE
1. ALL RESISTORS ARE
  2. ALL CAPACITORS IN



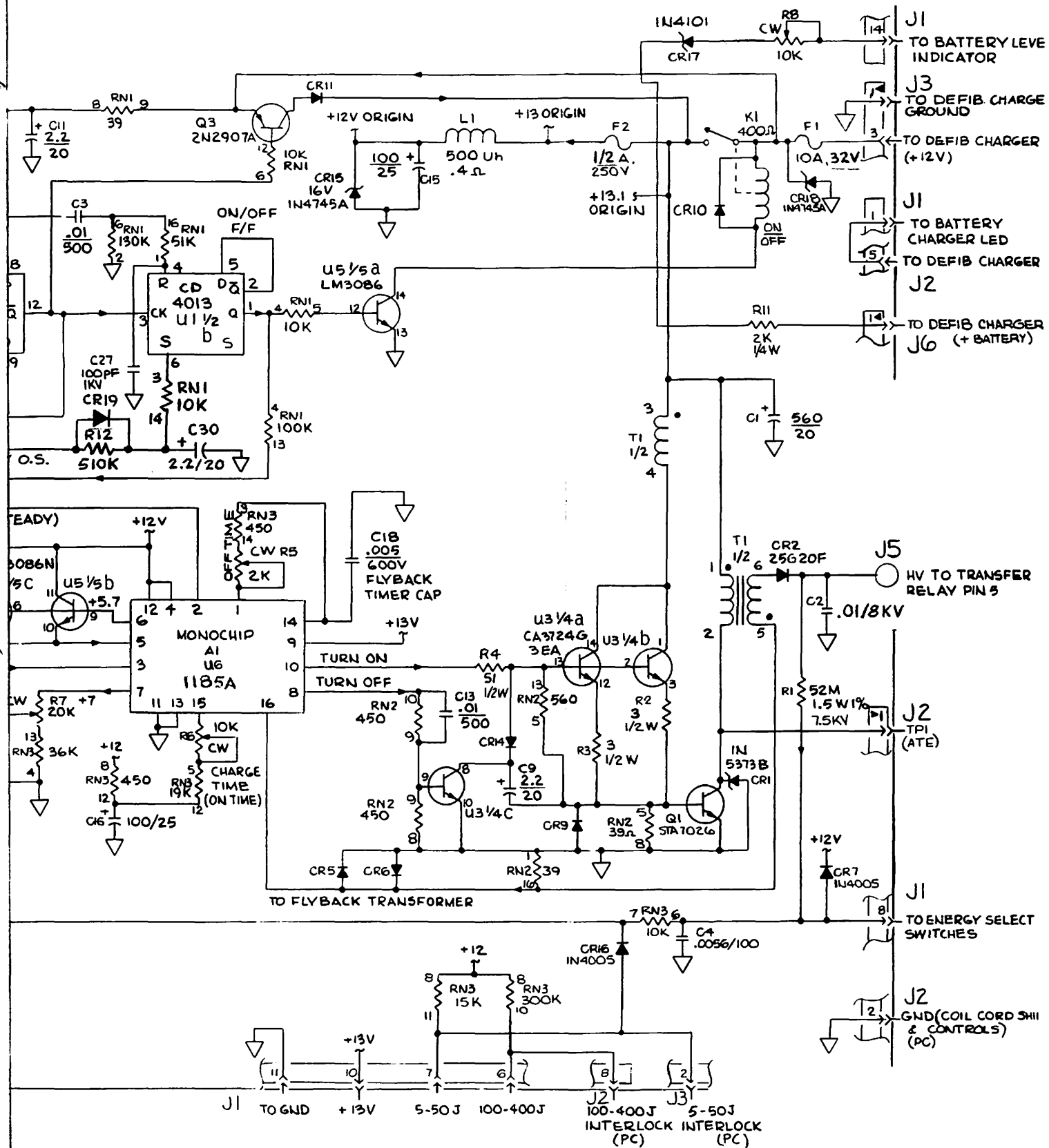

SPECIFIED  
IN OHMS, 1/4W, 5%.  
MFD/WVDC.

800163

FIGURE 3-15. MAIN BOARD SCHEMATIC

3-47/3-48

Jan 1979

### 3-14. Main Board Circuitry (continued)

#### A. On-Off Control (continued)

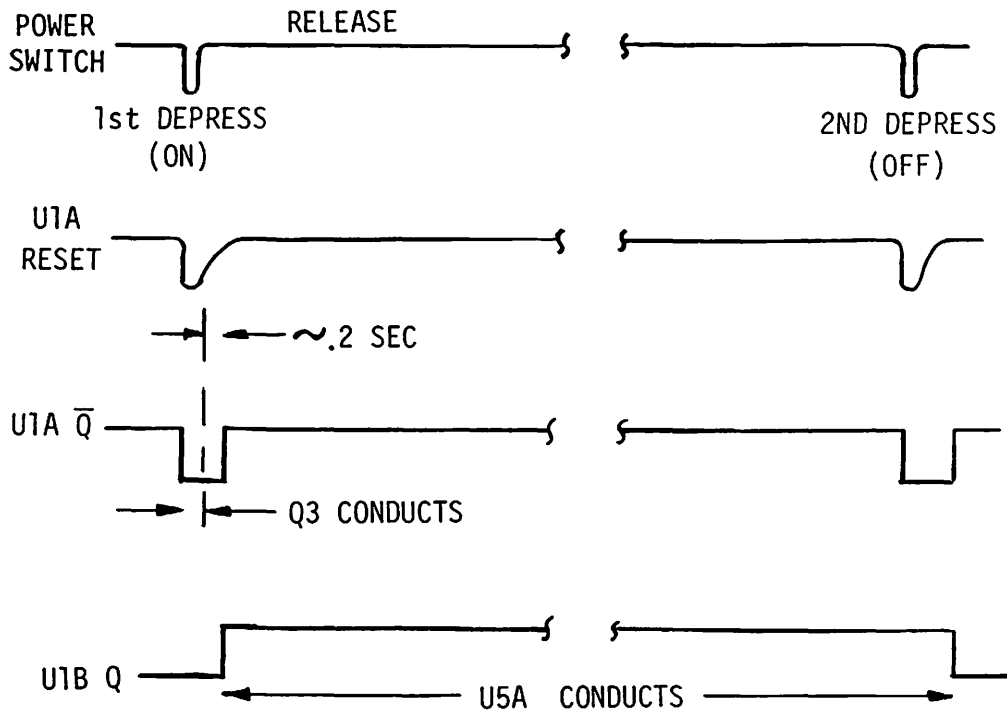

FIGURE 3-16. ON-OFF CONTROL

When U1a finally reverts to its reset state (about 0.2 second after POWER switch release), its Q pin reverts to high, shutting off Q3. The leading edge of the high constitutes a clock input to type D flip-flop U1b. At some earlier time, when +12 volt charger input first became available, it had pulsed through C3 to reset U1b so that flip-flop's Q output was a low that switched off transistor U5a. Now, with the clock input to U1b going high, its Q output toggles high, turning on U5a and thus completing the K1 winding path from +12 volts to ground. The K1 relay accordingly energized, thereby completing the high capacity circuit to the transformer T1.

For subsequent normal turnoff of the +12 volt input, the action is comparable, except that U1b does not experience a reset high pulse through C3. Again, the POWER switch is momentarily depressed, sending a low pulse to U1a, pin 10. This causes U1a to enter its set state, with its Q output going low. After about 0.2 second, its Q output reverts to high, the leading edge constituting a new clock input to U1b. This second clock input causes the Q output of U1b to toggle from its previous high to low. As a result U5a transistor turns off, breaking the K1 coil path to ground. The K1 wiper accordingly opens.

### 3-14. Main Board Circuitry (continued)

B. Voltage Supply. The control and indicator DC loads throughout the defibrillator module are supplied from the main board. The nominal +12 volts for the POWER, SYNC, and CHARGE switch lamps is tapped from the load side of fuse F2 and supplied directly from charger input (J3-3). The nominal +12 volts is derived from charger input after filtering in L1 and C15. Protection against transient overvoltages is provided by Zener diodes CR15 and CR18. The +5 volt supply is derived from application of +12 volts to monochip U6, which produces a regulated +5.7 volt output at U6, pin 6. This +5.7 volts is applied to the bases of two emitter-follower transistors in parallel, U5b & c. The output at the emitters is consequently the 5.7 volts minus the base-emitter diode drop, or 5 volts. That 5 volts is channeled to monochips U6, U4 and U2, pins 5, 14 and 12 respectively. U6 provides in addition, a +7 volt supply derived from the +12 volts. Outputted at U6, pin 7, it is applied to potentiometer R7, adjusted there to about 6 volts, and applied to U4, pin 7 as the reference voltage for the energy-level comparator in U4.

C. Control Initialization. The control functions on the board center in monochips U2, U4, and U6. Principal stages in U2 are a ready oscillator and a flip-flop whose two states correspond to two selectable modes: synchronized cardioversion or defibrillation. Stages in U4 include a dump relay flip-flop, a charge flip-flop, and an energy-level comparator. A principal feature of U6 is a charge oscillator.

As part of the turn-on process, the low appearing at Q terminal of U1b during and until shortly after the first depression of the POWER switch acts as an reset pulse to the flip-flops in U2 and U4.

It resets the sync/defib flip-flop to defibrillation mode, the dump flip-flop to de-energized state, and the charge flip-flop to non-charge state. Holding these states until the Q terminal of U1b goes high ensures that the +12, +7 and +5 volt supplies will have stabilized before active control is entered.

D. Active Control. After U1b-Q has gone high, chargeup of the high-energy storage capacitor can begin. That process is started by depressing either the CHARGE switch on the front panel or the charge button on the adult apex external paddle. Either action grounds common point J1-4, J2-7. This constitutes a set input to the charge flip-flop at U4, pin 13. That unit switches to the charge state, which causes the dump flip-flop in U4 to transition to its energized state. As a result, U4, pin 3 goes high. That high, applied to the bases of transistors U5d and U5e in parallel, causes those units to conduct and thus their collectors, tied to J3-6, to go low. In consequence, the transfer relay dump coil, also tied to J3-6, is energized. Until now, the coil, de-energized, has passively allowed the relay high-voltage contacts to stay in their normally closed position that completes a 100K ohm resistor

### 3-14. Main Board Circuitry (continued)

#### D. Active Control (continued)

path connected across the high-energy storage capacitor. This provision has ensured that the capacitor initially is essentially drained of charge and therefore safe. (Incidentally, power or instrument failure, with consequent de-energizing of the dump relay and passive closing of the 100K ohm path across the capacitor, will drain off a full charge within 20 seconds). Now, however, the dump coil having been energized, the 100K ohm dump relay opens the bleed path so that subsequent capacitor charge-up may proceed.

In transitioning to charge state and thereby signaling the dump relay to energize, the charge flip-flop has, in addition, applied a high (+5 volts) through internal resistance to U4, pin 11 and thence to capacitor C21. As C21 charges, the voltage across it called signal CD & RL1 (charge delay and ready light interface) builds until, after about 100 milliseconds, it exceeds approximately 3.5 volts. At that level it constitutes a command via U6, pin 3 ordering the oscillator in U6 to operate and thereby initiate energy storage capacitor charge-up. The 100 millisecond delay gives the dump coil sufficient time to disconnect the 100K ohm shunt from the storage capacitor before charge-up begins.

The oscillator in U6, commanded on when the signal to U6, pin 3 exceeds +3.5 volts, provides a square-wave output unsymmetrical with time. That output, appearing at U6, pin 10 (and in complementary form at U6, pin 8), goes high for 50 microseconds, then low for a shorter variable period (about 20 to 30 usec) to complete one cycle. Each 50-usec high from U6, pin 10 turns on paralleled transistors U3a and U3b, thereby driving Q1 base positive and essentially shorting Q1 collector to ground.

During the 50-usec, the DC current through primary winding 1-2 of T1 increases from zero to Q1 saturation level. This maximum current produces a large magnetic flux in T1 core. The flux buildup has induced a large voltage in T1 secondary, so that winding end point 6 goes negative. Diode CR2 prevents coupling of this negative voltage to J5, the high-voltage connector.

During the 50 microseconds, C9 has charged up via the base-to-emitter signal of Q1. After the 50 usec period ends, the reverse phase of the oscillation begins, with U6, pin 10 changing from high to low and its complement terminal, U6, pin 8, switching from low to high. The significant result is that the U6, pin 8 high turns on transistor U3c, causing C9 positive plate to be shorted through U3c collector to ground. Inasmuch as the voltage across C9 cannot change instantly, the result is a negative pulse to the base of Q1, turning that transistor off almost immediately. The consequent quick collapse of the flux in T1 induces a high voltage in T1 secondary with winding endpoint T1-6 going positive. A resultant current pulse is conveyed through CR2 and output jack J5. From there, off board, it passes through the normally closed contacts of the transfer relay

### 3-14. Main Board Circuitry (continued)

#### D. Active Control (continued)

and is stored as an incremental charge on the energy storage capacitor. The return path is through series inductor L1, through another set of normally closed contacts on the transfer relay, and thence back to ground at J3-8 on the main board.

As long as the discharging current is flowing, terminal 5 of T1 secondary is inductively driven negative with respect to ground, the magnitude of the negative voltage being limited to the drop across conducting diode CR6. This negative signal, applied to pin 16, of U6 maintains the turn-off line high and the turn-on line low as long as the negative condition endures. When all the energy stored as T1 flux as a result of the previous 50-usec on-period has been transferred to the storage capacitor, current ceases in T1 secondary.

Consequently, T1-5 reverts to ground potential; i.e., the negative signal to U6, pin 16 ends. The turn-off phase, however, is sustained for an additional, fixed period. This fixed period depends on the values of R5, RN3, and C18 connected to pins 1 and 14 of U6. During calibration, potentiometer R5 is adjusted to a value such that the fixed final portion of the off phase lasts long enough (about 10 usec) to damp out energy-dissipating oscillations in T1.

In all, the off ("flyback") phase of a charging cycle lasts about 25 usec. The turn-on phase is set to 50 usec by adjusting R6 in the RC circuit external to U6, pin 15. Thousands of successive on-off charging cycles such as the one just described is required to charge the storage capacitor stepwise to one of nine discretely selectable energy levels (5, 10, 20, 30, 50, 100, 200, 300 or 400 joules). An optional, tenth level is 500 joules. The charging process is stopped when the incrementally increasing voltage across the capacitor reaches a magnitude corresponding to the desired amount of joules.

This quantity is selected by appropriate setting of the ENERGY SELECT switch on the front panel. The wiper of the switch is interconnected to the main board at J1-8 and thus to the low potential end of 52 megohm resistor R1 whose high end senses the voltage on the energy storage capacitor. In any given setting, the switched path from J1-8 passes through the ENERGY SELECT switch wiper and a selected resistor on the control panel, then back through interconnect wiring to the main board at J1-6 or J1-7 (depending on joule range). Those two points are connected to ground via J2-8 and J3-2 respectively and interlocks on the wiring harness and the paddle connectors.

### 3-14. Main Board Circuitry (continued)

#### D. Active Control (continued)

The voltage at J1-8 is a small proportion of the storage capacitor voltage, that proportion equaling the ratio between  $R$  and  $R + 52$  megohms, where  $R$  is the resistance of the Selected resistor on the control panel. That fraction of the increasing voltage at J5 is conveyed to monochip U4, pin 5, the signal input to a comparator. The comparator reference voltage is approximately 6.2 volts, obtained from potentiometer R7 and applied to U4, pin 7.

When the signal climbs to this reference level, comparator output switches, causing the charge flip-flop in U4 to reset. The reset flip-flop drops the CD & RL1 signal output at U4, pin 11, from its previous greater-than 3.5 volt level (typical 5V) to the 2-volt level. This causes the charge-up oscillator in U6 to stop operating. In consequence, charging of the storage capacitor halts. While the charging process has been proceeding pin 2 of U6 has remained high at the level it switched to when the charge-up oscillator was commanded to operate. Meanwhile pin 3 of U4 has also remained high, at the level it attained when the dump flip-flop in U4 was commanded to its energized state. These two concurrent highs, conveyed to monochip U2, pin 10 and 9 respectively, and there to start a square-wave 1 Hz oscillator in U2. Each positive half cycle, appearing at pin 8 of U2, causes the LED lamp on the apex paddle to light for that 0.5 second period. Each negative half cycle, appearing at pin 6 of U2 as a ground-level output, causes the CHARGE lamp on the front panel to light for that 0.5 second period. Thus during the charging progress, both lights will blink on and off once a second. The 1 Hz frequency is determined by U2 internal elements plus capacitor C7.

When the charge-up oscillator is commanded to cease operating, the selected joule level having been reached, pin 2 of U6 goes low. Pins 8 and 6 will go fixed high and low respectively, causing steady lighting of both the CHARGE lamp and the apex lamp. If subsequently before application of the stored charge, that charge bleeds down sufficiently to drop the capacitor voltage more than 5%, the energy level comparator hysteresis lag of 5% will be exceeded and the comparator output will revert to not ready condition. In that case, the charge indicator lamps will blink, until either the desired charge level is restored after operator re-initiation of the charge-up process, or the energy select switch is rotated or the main power is turned off.

- E. Defibrillation Discharge. While the sync/defib flip-flop in U2 is in defib mode, pin 4 of U2 maintains a steady high which, applied to the SYNC lamp on the front panel, keeps that lamp off. In that mode, when the selected amount of energy has been stored (indicated by steady lighting of the charge lamps), the operator can command its discharge to the patient. The command is effected by depressing both discharge switches simultaneously on the external paddles or the single switch on the control panel.

### 3-14. Main Board Circuitry (continued)

#### E. Defibrillation Discharge (continued)

Discharge switch depression grounds J2-3. This ground, appearing at U4, pin 16, traverses a transfer-enable gate in U4 (when the energy level comparator output is high) and causes the transfer single shot multivibrator in U4 to transition to its set or high state of about 200-millisecond duration. The output of the single shot flip-flop, going high at U4, pin 9 for the 200-msec accomplishes four things: (a) applied to U2, pin 16, it acts to reset the sync-defib flip-flop to defib mode for the next time the instrument is used. (With the instrument currently in defib mode, this reset is academic. The same action, however, occurring in sync mode, resets the instrument to the safe mode for next use.) (b) at U2b, pin 6, the set input of the on-off flip-flop, it holds that flip-flop in on status during the transients caused by subsequent storage capacitor discharge, (c) it turns on transistor U3d, which in turn turns on transistor Q2, transmitting a low through J3-7 to energize the transfer relay and (d) internally in U4, the 200-msec singleshot output resets the dump relay flip-flop to de-energized state. This causes the bleed resistor to shunt the energy storage capacitor even as the charge is applied to the patient. The discharge is accomplished, however, before any significant amount of the energy is bled down.

The energizing of the transfer relay connects the storage capacitor and inductor combination via the relay DPDT wipers to transfer relay pins 6 and 9, thence to paddle connector pins J1-11 and J1-8, and on to the paddle electrodes.

In addition, the energizing of the transfer relay opens normally closed ECG "Quik-Look" contacts on the transfer relay, thus disconnecting the monitor preamplifier from the paddle electrodes.

- F. Synchronized Cardioversion. When the defibrillator is used alone, the automatic turn-on sequences, as explained earlier, set the sync/defib flip-flop in U2 to defibrillation mode. However, when the defibrillator and monitor modules are connected together and both are turned on, either synchronized cardioversion mode or defibrillation mode can be selected by means of the SYNC switch on the front panel.

In that joint configuration, each momentary depression of the SYNC switch toggles the defib/sync flip-flop from whichever of the two states it is in to the opposite state. Switch depression applies +2 volts from the panel to J1-13 and via C12 as a clock pulse to the flip-flop to sync status, its output at U2, pin 4 goes steady low, causing the SYNC lamp to light. Moreover, its Q output at U2, pin 2 goes high to about +4.3 volts. The high, applied to U4, pin 1, disables the transfer gate until a systole pulse is received. The systole pulse, received from the monitor interface at J4-2, appears as a +5 volt signal of 10 millisecond duration, which is applied to two circuits; (a) appearing at U2, pin 3, it

### 3-14. Main Board Circuitry (continued)

#### F. Synchronized Cardioversion (continued)

turns the SYNC lamp off for 80 to 100 milliseconds (in U2, the 10 msec is lengthened to 80-100 msec as the effect of C6 connected to U2, pin 1). The visible blinking off of the lamp for that approximate 0.1 second per heart beat informs the operator that the systole signals are being received; (b) appearing at U4, pin 15, the 10-msec 5-volt pulse is one of the coincident conditions enabling the transfer gate in U4.

As in defib mode, another requisite enabling the transfer gate is charge ready condition. When the gate is enabled, depressing the discharge switch or switches sends the discharge command through the transfer gate. The subsequent transition of the single-shot flip-flop to its 200 millisecond state accomplishes the same results as in defib mode; with the exception that the discharge of the stored charge is now in synchronization with the detected R-wave.

- G. Energy Level Change. If the operator selects a new energy level while the storage capacitor is charging up or after it has charged to the previously selected level, that charge stored earlier will be dumped and charge-up to the new limit will be instituted by the operator. The sequence is as follows:

The energy selected switch on the front panel is of the type where rotation from one setting to another opens the wiper circuit while the wiper is in transit. Switch rotation therefore briefly opens the circuit between the low end of 52 megohm resistor R1 and the voltage division resistors in the energy select switch circuit to ground. The undivided high voltage is applied through R1 to C4. The voltage at U4, pin 5, quickly rises to +8 volts or more. When U4, pin 5, input exceeds about 8 volts, an energy dump comparator in U4 is caused to transition. The changed comparator output resets the the dump flip-flop to de-energized status and the charge flip-flop to non-charge status. As a result, the energy in the storage capacitor is dumped, and if charging was in progress, the charging is suspended. When the select switch is then placed anew on a set position, normal sequencing resumes.

- H. 500 Joule Option. When the 500 Joule option is installed, a 46 uf energy storage capacitor is employed instead of the standard 36 uf unit, a 500 joule setting is added to the energy select switch, and a 500 joule switch is added to the front panel, as is an appropriate resistor for voltage division at J1-8. To initiate charging when the energy select switch is in 500 joule position, both the CHARGE switch and the 500 JOULE switch must be depressed simultaneously.

With the instrument on but before charging starts, the comparator circuit in U4 produces +1.5 volts at the comparator input, U4, pin 5 (See Figure 3-17). With the energy select switch in 500 JOULE setting,



3-14. Main Board Circuitry (continued)

H. 500 Joule Option (continued)

that +1.5 volts is conveyed via J1-8, the select switch wiper, the 500 Joule position voltage-division resistor, and interconnect wiring to J1-5 on the main board and thence to U4, pin 12.

With the +1.5 volts at U4, pin 12, a charge command, inputted to U4, pin 13, by actuation of either charge switch, will be inhibited. Actuation of the 500 JOULE switch will short the +1.5 volts to ground so that with concurrent actuation of either charge switch, (the charge command at U4, pin 13), now gated, will set the charge flip-flop in U4 to charge state.

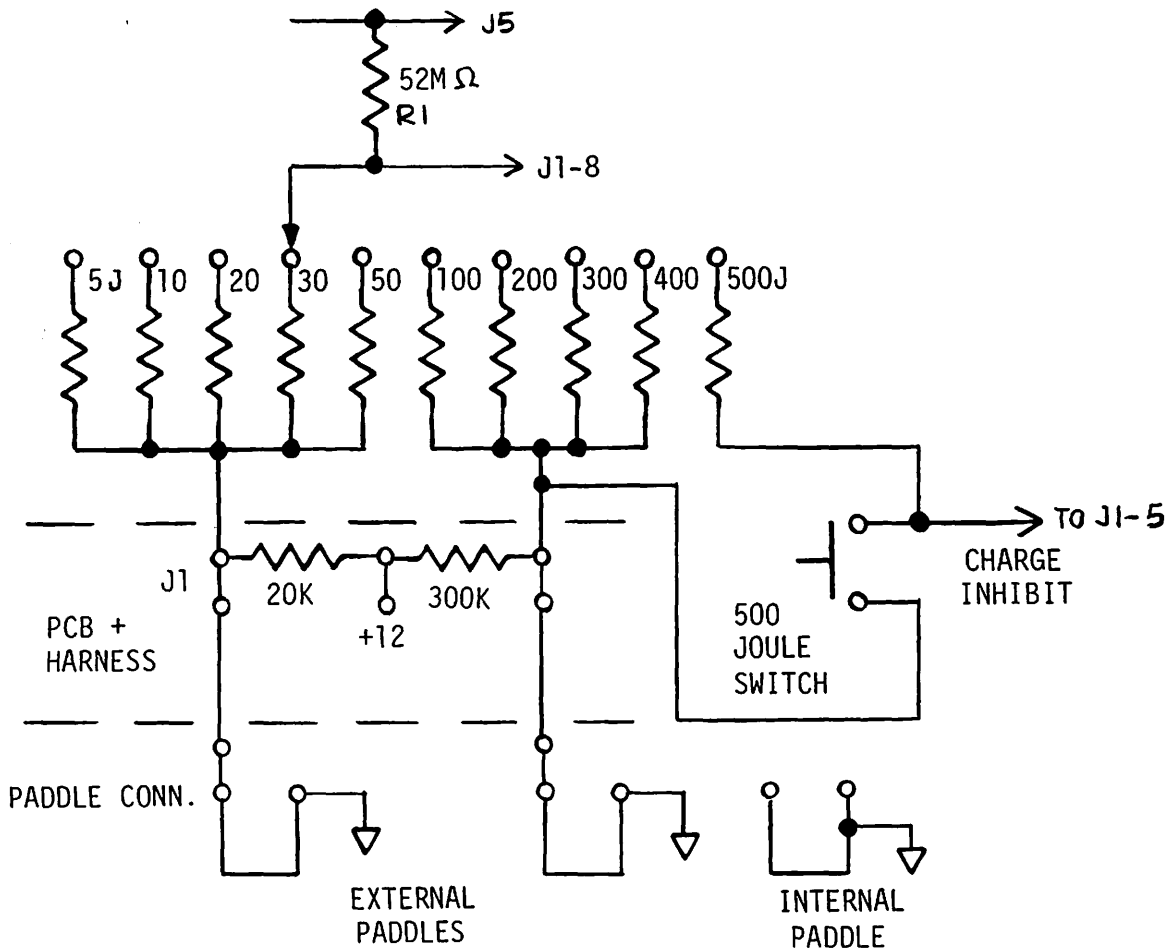

FIGURE 3-17. PADDLE INTERLOCKS PATH TO GROUND

- I. Interlocks. Figure 3-17 shows the paddle interlock paths to ground, establishing the voltage division for energy sensing in the main board energy level comparator.

### 3-14. Main Board Circuitry (continued)

#### I. Interlocks (continued)

With adult external paddles employed, main board points J2-8 and J3-2 are grounded via the jumpers in the paddle connectors. Thus, the low potential ends of both banks of voltage division resistors are normally grounded (namely the 5 to 50 joule bank and the 100-400 or 100-500 bank).

If the ground path through J3-2 is broken while the energy select switch is in any low range setting (5-50) or if the ground path through J2-8 is broken, in any high range setting, and with the storage capacitor at least partly charged, the voltage division does not occur. As discussed under energy level change, this will halt charging and dump any charge on the storage capacitor.

If the ground interlock path is broken but with no charge on the storage capacitor, the +12 volts at RN3, pin 8, will be applied via an energy select switch path to J1-8 and comparator input U4, pin 5, with the result that charging is inhibited.

- J. Battery Monitoring. For battery condition monitoring, the +12 volts (from the battery via J6-1 and the defib charger assembly) supply voltage level is dropped by 8.2 volts (the fixed voltage across Zener diode CR17) and the difference is applied through adjustable resistance R8 and J1-14 to the BATT LEVEL meter on the defibrillator panel. The reading of this meter is significant only when the battery is actually under the load, of the defibrillator charge-up circuitry.

In calibrating the meter, +10.5 volts is substituted at J6-1 (for the battery) and R8 is adjusted for meter deflection to center scale. This reading corresponds to the voltage experienced when only 20% of full battery charge remains.

- 3-15. Defibrillator Charger Board. The defibrillator charger board, performs three functions: conversion of line AC to DC for application to the main defibrillator board; charging the alternative power source, a battery; and automatic transfer between the two power sources. The basic 115-volt AC configuration is described below. For the 230 volt option, working voltages at collectors of Q1, Q2 and C1 and C2 should be doubled; otherwise the same description suffices (see Figure 3-18).

The AC conversion involves rectification to 150 VDC, use of the 150 VDC to generate a 20 kHz square-wave, and square-wave rectification to 12 volts DC. In the initial step, the line AC is applied directly to a full-wave bridge employing diodes CR1 through 4. Filtering the bridge output, series inductor L1 serves principally to block radio frequency interference; capacitors C1 and 2 bypass power line frequencies. The nominal no-load rectifier output across C1, C2, and C3 is 150 VDC.

Transistors Q1 and Q2 and transformer T2 are principal elements of a square-wave oscillator, the transistors conducting alternately to produce a 20 kHz output to transformer T1.

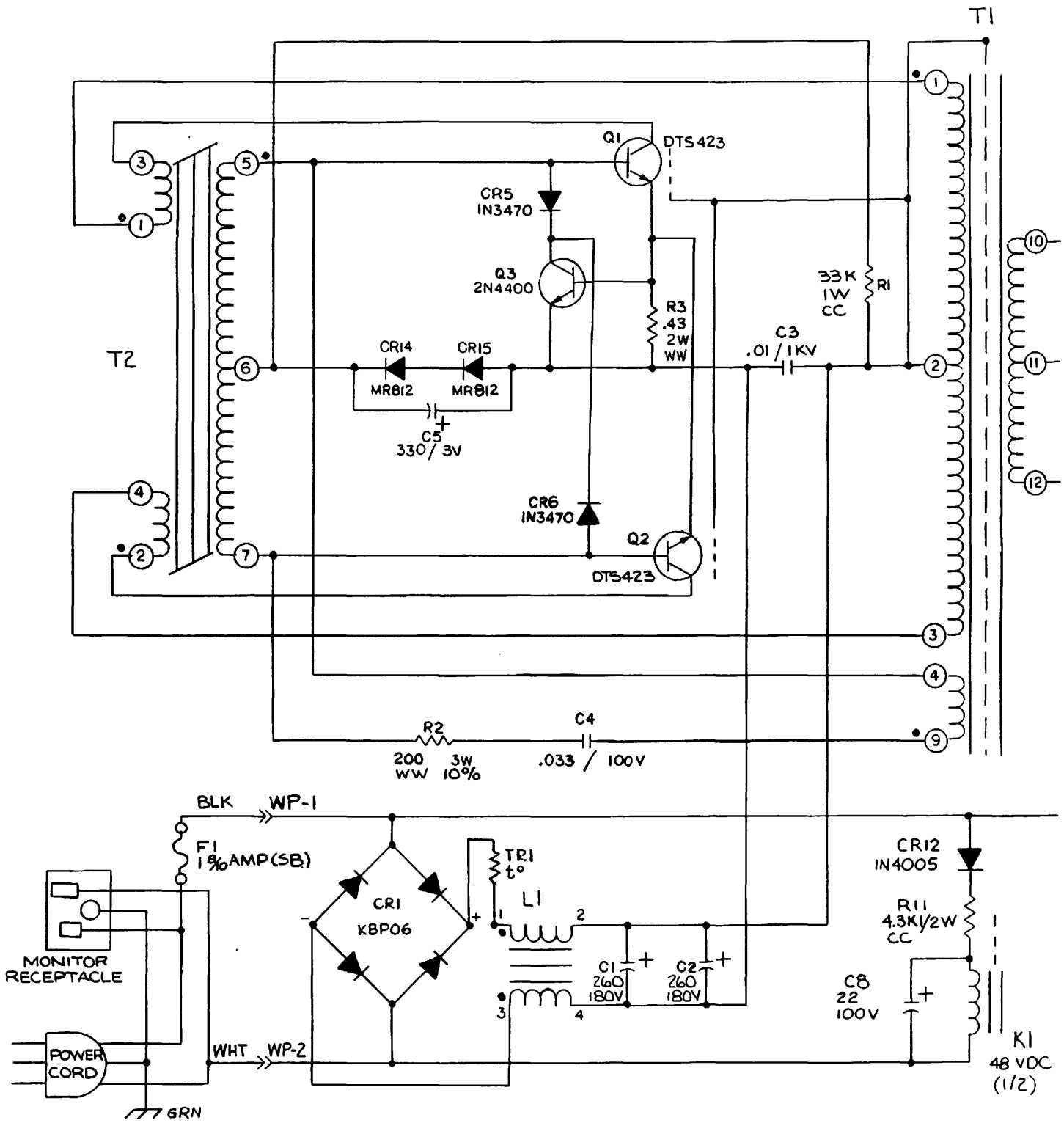



### 3-15. Defibrillator Charger Board (continued)

Q1's DC path is from the positive lead of C3 (the voltage supply) through T1 winding 2-1, T2 primary winding 1-3, Q1 collector to emitter, R3, and back to C3 negative lead. Q2's DC path is T1 winding 2-3, T2 winding 4-2, Q2 collector to emitter, and R4. Positive feedback for Q1 and Q2 is provided respectively by T2 secondary windings 6-5 and 6-7.

Resistor R3 senses Q1 and Q2 emitter currents. If this current exceeds a safe value (about 3 amperes), the positive-going base of Q3 will turn on that transistor, thus shorting out the base drive of Q1 and Q2.

In phase with the alternate Q1 and Q2 conduction, points T1-1 and T1-3 are alternately connected to the negative side of the +150 volt supply voltage. Hence, the 150V potential at T1-2 is alternately referenced to T1-1 and T1-3. By virtue of autotransformer action, an imposed voltage across half of T1 primary results in a voltage of equal magnitude across the other primary half. The peak voltage across T1 primary winding 1-3 is therefore approximately 300V, as is the peak voltage between Q1 collector and Q2 collector. Note that C3 negative lead is not grounded and should not be inadvertently grounded during test connection.

For square-wave rectification, as T1 secondary winding points 10 and 12 alternatively swing 12-volts negative with respect to center tap 11, diodes CR8 and then CR9 alternately conduct, providing full wave rectification. The output, filtered by L2 and C6, is +12 volts, appearing between the normally open contact of relay K1 and J2-4. CR8 & 9 are Schottky diodes capable of conducting the 10 ampere load current required by the defibrillator board. Zener diodes CR16 and 17 limit reverse voltages across CR8 and 9 respectively to 27 volts and thus provide reverse breakdown protection for those units.

As soon as AC line voltage is applied to the bridge rectifier CR1-4, it is half-wave rectified by CR12 and applied to the 48VDC actuating coil of relay K1. The energized coil then causes wiper C to connect the normally open contact of K1 to J2-4 as output to the main board.

At startup or with no load on T1 secondary, a small transient voltage is induced in T1 winding 4-9 by flux change through T1 winding 2-3. Assume for example that this winding 4-9 voltage is applied in positive sense to Q1 base. Some resulting small current will begin through Q1 collector. That current, conveyed through T2 winding 1-3, induces in winding 5-6 a voltage driving Q1 base further positive. This positive feedback cycle will progressively re-occur, causing Q1 to be forced rapidly to saturation.

As Q1 current approaches saturation, its rate of increase diminishes toward zero and so therefore does the induction of positive voltage at T2-5. The lessening of base drive in turn reverses the collector current buildup. Thus T2 flux starts to drop, causing the voltage induced in its windings to change polarity. Q2 base becomes positive and Q2 collector current mounts rapidly from zero toward saturation. With Q saturation, the inverse cycle begins anew.

### 3-15. Defibrillator Charger Board (continued)

Thus T2 flux and current oscillate and so in step does the T1 primary current and the induced voltage output from T1 secondary 10-12. Transformer T2 operates in the saturated flux density region. This fact, augmenting the sharp saturation characteristic of Q1 & 2, makes for a close approximation to the ideal square-wave transformer output waveform. Wave squareness and relative high frequency, compared to sinusoidal line frequencies, makes for efficient transformer action. As a result, T1 and T2 together are much lighter and less bulky than the alternative, a step-down transformer operating at line frequency.

If line voltage drops out, the charge on smoothing capacitor C8 quickly drains off through K1 coil, allowing rapid actuation of K1 wiper to the normally closed contact so that the alternative power source, the 12-volt 1 ampere-hour battery, will be connected from J1-2 to the J1-5 output terminal point.

As long as line voltage is applied to K1 relay, the battery is disconnected from supplying output through J2-4 and is instead trickle-charged. The charging current is obtained through rectification of the 24-volt 20 kHz output from T1 winding 10-12. The bridge rectifier consists of CR7, CR8, CR9 and CR10, which apply approximately 24 volts DC to C7. The trickle current is maintained at 100 mA by means of transistor Q5. For voltage regulation, transistor Q7 is used as a zener diode, emitter to collector. Potentiometer R6 is adjusted to make Q5 collector current 100 mA. The R7 drop, because it indicates charging current is flowing, also serves to turn on Q6 and pass through it current that will light the LED called BATTCHG on the defibrillator control panel. Diode CR13 prevents battery discharge through Q5 collector when the charger is disconnected from line power.

- 3-16. Test Load Board. The test load circuit is designed to light the indicator when 200 joules is discharged through the load and to maintain the indicator dark when 100 joules is discharged. It thereby serves to test that the defibrillator stored charges at energy select settings 200 and 100 are at least approximately correct (see Figure 3-19).

With the paddles resting in their normal location on the contact plates on the front panel, the charged capacitor is discharged by depressing both discharge switches. Either paddle may be on either plate. The discharge voltage is impressed across R1 and R2 in series, with R2 seeing approximately 1.3% of the input. This fraction, which may be of either polarity, is polarized by rectifier bridge CR1 so that the cathode of Zener diode CR2 is positive. Because the breakdown voltage of CR2 is 22 volts, the voltage across R3 is the voltage across C1 minus 22 volts. When R3 potential drop exceeds approximately 2 volts, Q1 turns on Q2. The conduction of Q2 lights LED CR1. In addition, the collector of Q2 going high latches Q1. Q2 conduction is extended until the energy stored in C1 is dissipated. When that capacitor is drained, Q1, Q2 and the LED turn off. The next test discharge must be postponed at least 30 seconds to allow heat dissipated in R1 and R2 to be dissipated.

NOTES: UNLESS OTHERWISE SPECIFIED

1. ALL RESISTORS ARE IN OHMS, 1/4W, 5%.
2. ALL CAPACITORS IN MFD/WVDC.

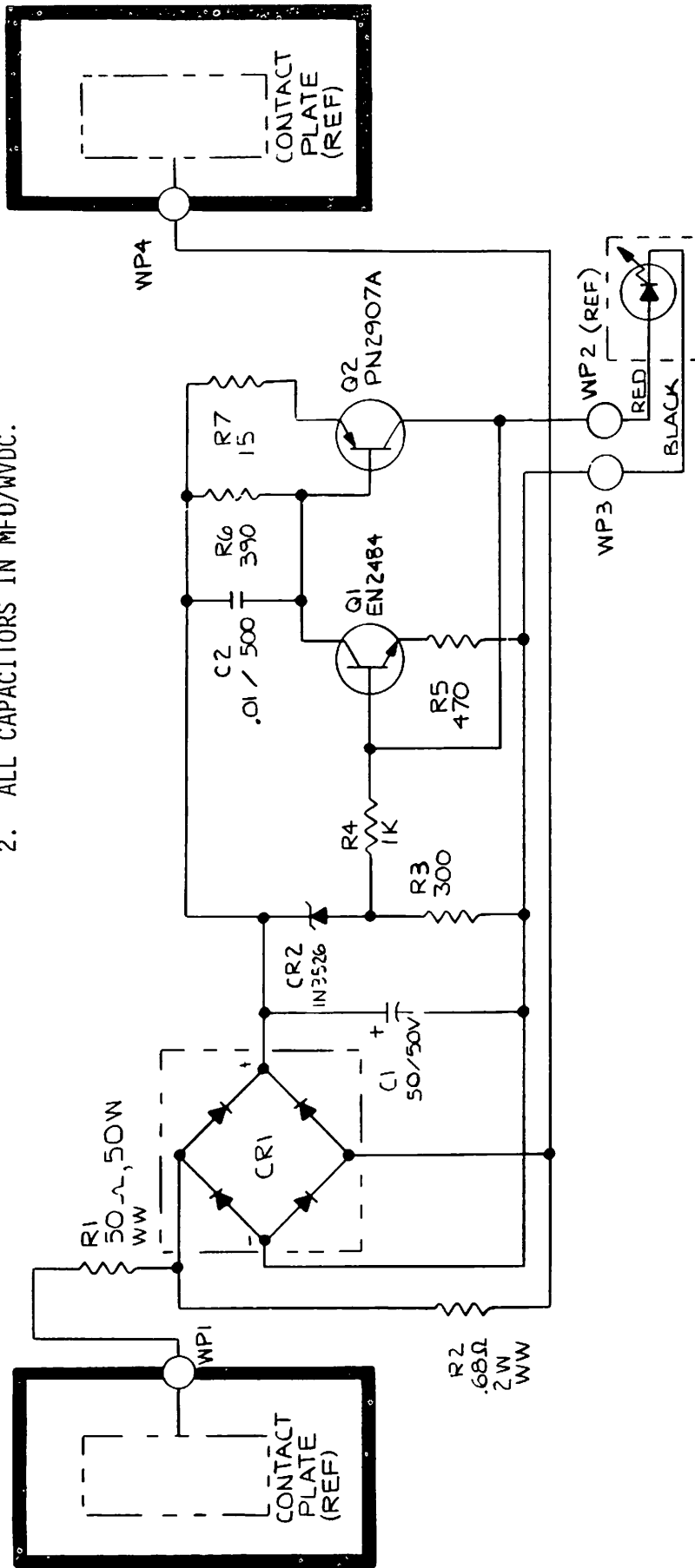

800167

FIGURE 3-19. TEST LOAD BOARD SCHEMATIC

## SECTION IV MAINTENANCE

### 4-1. INTRODUCTION

This section provides maintenance, servicing and calibration procedures for the LIFEPAK 6 instrument. Included herein is a list of recommended test equipment and a troubleshooting guide for help in fault isolation. Troubleshooting, repair, test and calibration, and component removal should be attempted only by qualified personnel thoroughly familiar with the circuit description presented in Section III. Circuit boards needing repair should be returned to Physio-Control for servicing.

The section is organized into three major parts. The first major part provides general information applicable to both units. Subsequent parts are presented by cardioscope/recorder followed by the DC defibrillator.

### 4-2. GENERAL

The following paragraphs 4-3 through 4-6 provide general information for the instrument. This section is divided into four major topics which include warranty, test equipment, repair techniques and cleaning information.

- 4-3. Warranty. LIFEPAK 6 is warranted against all defects in parts and workmanship for a period of one year from date of delivery; patient cable and stylus 90 days. Physio-Control will repair or replace any products which prove to be defective during the warranty period, provided proper use and maintenance procedures are followed as described in the operating and service manual.

All defective products or components must be returned to Physio-Control, or its authorized service center, with a detailed explanation of the failure. Transportation charges must be prepaid.

Service performed, other than stylus replacement, by other than Physio-Control or its authorized agents may, at the discretion of Physio-Control be cause to void this warranty.

No other party is authorized to make any other warranty, or to assume any liability for Physio-Control products. No other warranty, either implied or in writing will be recognized.

- 4-4. Test Equipment. Test instruments suitable for maintenance and calibration of the LIFEPAK 6 are listed in Table 4-1. Although specific, commercially available test instruments are recommended, other test equipment with specifications equivalent to those listed may be used.



TABLE 4-1  
TEST EQUIPMENT

NOMENCLATURE	CHARACTERISTICS	MANUFACTURER
DC Power Supply	Output Voltage: 0-20 VDC Output Current: 0-10 amps	Deltron Model SP20-10
Oscilloscope	Bandwidth: DC to 10 MHz Vertical Sensitivity: 5mV/div to 50V/div Input Impedance: 10 megohms Sweep Range: 1 usec/div to 1 sec/div	Tektronix Model 465
Digital Multimeter	Range: 0 to 1000 volts fs Accuracy: 0.5% of full scale on DC volt and resistance ranges, 1% of reading on AC voltages.	Fluke 8000A with high voltage probe (2 required)
Voltmeter (VOM)	Range: 0-5K Vdc (20K ohms/volt)  Accuracy: $\pm 3\%$	Triplet 630 APLK
Defibrillator Energy Meter	Power Range: 0-1000 joules Load Resistance: 50 ohms $\pm 0.5\%$ Accuracy: $\pm 2\%$ of full scale for pulse width of 5 milliseconds.	Dempsey 429B, Mod 1
Stopwatch	Accuracy: $\pm 0.25$ seconds	
Variable Auto- transformer	0-140V rms 0-240V rms Current rating: 5 amp	General Radio W8MT3 (120V) Superior Electric, Type 3PN226 (230V)
Function Generator	Frequency Range: 20-120 PPM Pulse Required: Positive 0-5V 10m Sec	Kronhite Model 5400A
Isolation Transformer	250VA, 60 Hz	Stancor GIS-250
Heart Simulator Tin Heart		PCC Model 09-00041
Test Connector	3 pin male (mini)	Molex P/N
Extender Card		PCC No. 800334-00
Extender Card		PCC No. 800336-00
Heart Simulator, Polyrhythm		PCC Model 954-00

TABLE 4-1 (Continued)  
TEST EQUIPMENT

NOMENCLATURE	CHARACTERISTICS	MANUFACTURER
Gram Gauge	Range: 2-20 grams (Flat Tip)	Halda Dynamometer Type Gram Gauge (or equivalent)
Counter/Timer		Tektronix Model DC504
Removal Tool- Flex Circuit		PCC No. 800742

4-5. Repair Techniques. After expiration of the LIFEPAK 6 warranty, if repairs are found to be necessary, the following repair techniques should be used when repairing the printed circuit boards (PCB) used in the instrument.

- 1) Use soldering pencil with a rating of 25 watts. A bulky soldering gun is too hot to use on the printed circuit boards.
- 2) Use only 60/40 solder for low melting temperature. If needed, a non-corrosive flux can be used to aid in soldering flow. Board should be thoroughly cleaned and the repaired area coated with a lacquer, varnish or plastic afterwards.
- 3) A heatsink or similar device should be used in soldering semiconductor components. This helps prevent damaging the solid state devices.
- 4) Breaks in the printed circuit board lands are repaired by bridging with wire from pad to pad, and not by laying solder across the break. The heat from the soldering iron may cause the land to dislodge from the board.
- 5) Before removing a circuit board for repair or replacement, label each lead or draw a sketch showing the location of cables and wires.

CAUTION

Printed circuit boards in LIFEPAK 6 can easily be damaged beyond repair by improper handling. Through plated holes used to connect the circuitry on two sides of the board are particularly vulnerable to damage. UNSKILLED PERSONNEL SHOULD NOT ATTEMPT TO REPAIR ANY OF LIFEPAK 6 PRINTED CIRCUIT BOARDS.

4-6. Cleaning. For cleaning external covers, patient cable, and the CRT face, use a mild detergent type cleaner (i.e., "409," dishwashing liquid). Do not use alcohol, solvents or cleaning solutions. These agents may damage the surfaces of the instrument. For interior cleaning, use dry compressed air. A dry flexible paint brush can be used to dislodge thick dust.

#### 4-6. Cleaning (continued)

Remove electrode paste from paddle surfaces after each use with disposable tissues. Use a soft cloth with soap and water to clean paddles. If paddles become pitted, use 3M scotchbrite (abrasive pads) to smooth pits out. Toothpaste may be used to remove any discoloration. Do not use steel wool or autoclave, and do not immerse in fluids.

#### 4-7. COMPONENT IDENTIFICATION

Controls and indicators located on the instrument front panels are designated in the text by the exact name shown on the front panel, and appear in capital letters. For example; POWER.

#### 4-8. CARDIOSCOPE/RECORDER MODULE

The following paragraphs 4-8 through 4-36 provide maintenance procedures for the cardioscope/recorder and are divided into three topics: troubleshooting, test and calibration, and major component removal and installation.

Figure 4-1 provides an overall view of the cardioscope/recorder module with key components and test points or adjustments indexed to a legend.

- 4-9. Troubleshooting. Troubleshooting should start with observing for obvious symptoms such as odors from overheated components, or mechanical malfunctions. Use Table 4-2, Cardioscope/Recorder Module Troubleshooting Guide, to isolate specific malfunctions. Refer to paragraph 4-22 for procedure for major component removal and installation.

#### WARNING

TERMINALS AND WIRES CARRYING HIGH VOLTAGES ARE EXPOSED WITH THE LIFEPAK 6 COVERS REMOVED. OBSERVE SAFE WORKING TECHNIQUES. BE CAREFUL DURING TROUBLESHOOTING, TESTS AND CALIBRATION OR COMPONENT REMOVAL AND INSTALLATION.

- 4-10. Tests and Calibration. Procedures provided here are used to verify that the cardioscope/recorder is operating within specifications. If the instrument is not functioning properly locate the malfunction before attempting circuit calibration or adjustment. Refer to paragraph 4-7 for information concerning component location. Schematics of Section VI provide test point waveforms and/or voltages.

Note: For Synchronizer test, refer to paragraph 4-50.

TABLE 4-2  
CARDIOSCOPE/RECORDER MODULE TROUBLESHOOTING GUIDE

MALFUNCTION	POSSIBLE CAUSE	CORRECTIVE ACTION
1. Unit does not function when POWER pushbutton S2 is depressed.	a. Defective fuse F1 or F2.	a. Replace if necessary. If fuse opens when power is applied, check for short circuit in system power supply.
	b. Battery discharged	b. Recharge battery by plugging in to wall outlet.
	c. Defective system power supply.	c. Perform power supply tests, paragraph 4-12.
2. No luminous trace on cardioscope.	a. Defective CRT high voltage power supply.	a. Perform power supply tests, paragraph 4-12.
	b. Defective CRT sweep/deflection circuits.	b. Perform CRT trace checks and adjustments, paragraph 4-12.
	c. Defective CRT.	c. Replace CRT.
3. Interference on CRT trace when using patient cable as ECG pickup.	a. Poor electrode contact or placement.	a. Inspect electrode faces and reposition on patient.
	b. Defective patient cable.	b. Replace patient cable.
	c. Defective common mode rejection circuit in preamplifier.	c. Perform preamplifier checks and adjustments in paragraph 4-13.
4. Excessive 60 Hz interference on CRT when using external paddles as ECG pickup.	a. Defective paddles.	a. Replace paddles.
	b. Defective transfer.	b. Check transfer relay contacts for continuity (see DC Defibrillator troubleshooting).
	c. Defective slide contacts.	c. Check slide contacts on both modules.

(continued on next page)

TABLE 4-2  
CARDIOSCOPE/RECORDER MODULE TROUBLESHOOTING GUIDE (CONTINUED)

MALFUNCTION	POSSIBLE CAUSE	CORRECTIVE ACTION
5. No ECG signal on cardioscope when using patient cable, but CAL display is available.	a. Defective patient cable.	a. Check continuity of patient cable, or replace.
	b. Defective pre-amplifier circuits.	b. Perform preamplifier adjustments and checks, paragraph 4-13.
6. No ECG signal on cardioscope when using paddles for ECG pickup, but CAL display is available.	a. Defective paddles.	a. Replace paddles.
	b. Defective transfer relay.	b. Replace transfer relay.
	c. Defective Lead Select switch.	c. Replace switch.
7. Fuzzy or dim CRT trace.	Misadjusted CRT operating voltages. Poor connection at CRT connector.	Perform CRT adjustments paragraph 4-14. Clean CRT pins.
8. Recorder does not run.	a. Defective system power supply.	a. Perform power supply tests, paragraph 4-12.
	b. Defective paper drive motor.	b. Replace motor.
9. Recorder motor runs but no trace on paper.	a. Stylus HEAT set too low.	a. Perform recorder stylus replacement or adjustment in section II.
	b. Stylus bent or maladjusted.	b. Same as a.
	c. Defective heat circuit.	c. Check stylus heat circuit.
10. Recorder runs but stylus stays deflected to one side or does not respond and stays at center.	a. Defective pen drive motor.	a. Replace pen drive motor.
	b. Defective drive circuit.	b. Check pen motor drive circuitry.

(continued on next page)

TABLE 4-1  
CARDIOSCOPE/RECORDER MODULE TROUBLESHOOTING GUIDE (CONTINUED)

MALFUNCTION	POSSIBLE CAUSE	CORRECTIVE ACTION
11. No deflection when CAL switch depressed, but normal trace on CRT and signal when applied patient cable.	a. Defective switch.	a. Replace switch.
	b. Defective voltage divider in CAL circuit.	b. Check voltage divider.
12. No signal on CRT or recorder when signal is applied or CAL switch is depressed. Normal baseline trace on CRT.	a. Defective pre-amplifier circuit.	a. Perform preamplifier checks, paragraph 4-13.
	b. Defective No-Fade circuit.	b. Perform digital circuit checks, paragraph 4-14.
13. ECG signal does not freeze.	a. Defective No-Fade circuit.	a. Check U10 & U11 on No-Fade Board.
	b. Defective freeze switch.	b. Replace freeze switch.
	c. ECG size control set too low.	c. Adjust for larger ECG signal.
14. No systole sound.	a. Defective QRS VOL pot.	a. Replace QRS VOL pot.
	b. Defective operational amplifier or transistor.	b. Check components in systole sound circuit.
	c. Defective sonalert.	c. Replace sonalert.
15. Incorrect ECG display. Information is lost or distorted on cardioscope display.	No-fade circuit.	Perform digital circuit checkout, paragraph 4-14.
16. Incorrect ECG display in presence of transmitting equipment.	Loss of RF1 Shielding	Open unit and inspect conductive coating. If scratches or chips are apparent contact Physio-Control Service Department.
17. Defective Sync Function (Defib no sync'd to R-wave).	a. Defective slide contacts.	a. Check slide contacts on both models.
	b. ECG size control set too low.	b. Adjust for larger ECG until systole sound is present.

(Continued on next page)

TABLE 4-2  
 CARDIOSCOPE/RECORDER MODULE TROUBLESHOOTING GUIDE (CONTINUED)

MALFUNCTION	POSSIBLE CAUSE	CORRECTIVE ACTION
18. Inaccurate Rate Display.	a. ECG size control set too low.	a. Adjust for larger ECG until systole sound is present.
	b. Defective Rate Board	b. Perform rate board calibration, paragraph 4-15.
19. Upper or lower rate limits not operating at set rates.	a. ECG size control set too low.	a. Adjust for larger ECG until systole sound is present.
	b. Defective Rate Board.	b. Perform rate board calibration, paragraph 4-15.
20. No Rate alarm or systole sound.	a. Defective QRS volume control.	a. Replace QRS volume control.
	b. Defective sonalert.	b. Replace sonalert.

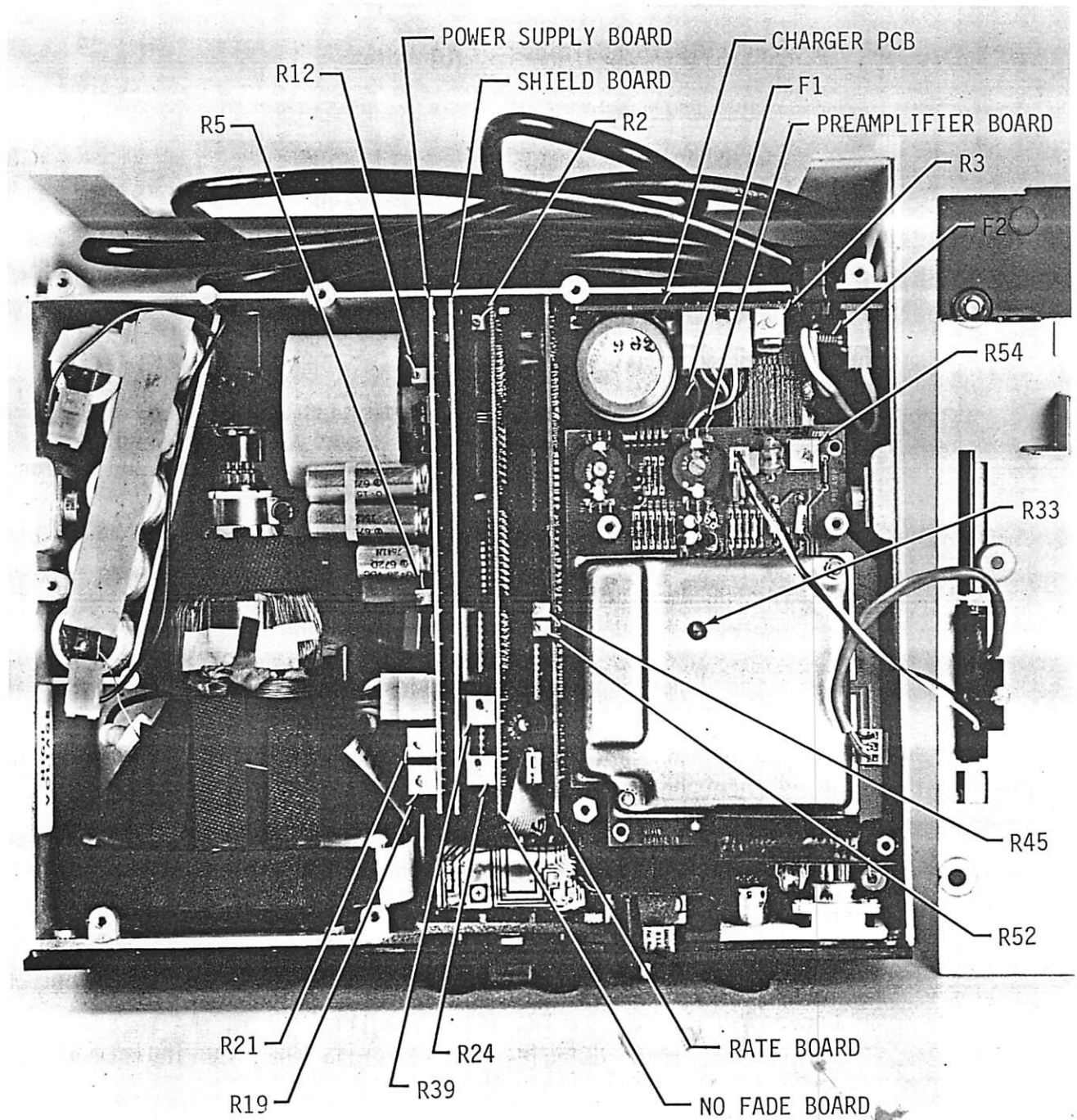

Figures 4-1. Cardioscope/Recorder Module Component Identification



#### 4-11. Initial Control and Setup

1. Disconnect the AC power cord from the external AC power source.
2. Separate the upper and lower case in accordance with paragraph 4-23.
3. Set controls to positions as follows:

<u>Nomenclature</u>	<u>Position</u>
POWER	OFF
DELAYED-OFF-REAL	OFF
QRS VOL	CCW
ECG SIZE	CCW
ECG LEAD SELECT	STD
ALARM LIMITS	OFF

#### 4-12. Power Supply Tests. After completing initial setup of paragraph 4-11, proceed as follows to accomplish power supply testing. Refer to Figure 3-13 for a schematic of the Power Supply/Deflection Board.

- a) Locate and remove fuse F1 on Charger PCB (800157).
- b) Set the DC Ammeter to read 500 mA full scale. Connect the DC Ammeter in series between the fuse F1 holder terminals.
- c) Place the Power Supply/Deflection Board (800112) on an extender card.
- d) Connect the oscilloscope (1 megohm probe) to the collector of Q1 or Q2 (PCB 800112).
- e) Connect the AC power cord to the external power source. Depress POWER switch on and verify that the converter amplitude on the oscilloscope is 35V P-P  $\pm$  2V P-P and the frequency is 20 KHz - 25 KHz.
- f) Verify that the DC Ammeter indicates 400  $\pm$  50 mA.
- g) Consecutively connect the digital multimeter to the test points indicated in Table 4-3 and verify that the individual power supplies are within tolerance.
- h) Depress POWER switch off. Disconnect the AC power cord from the external power source. Remove DC ammeter and replace fuse F1.
- i) Remove the Power Supply/Deflection board from extender card and plug board back in instrument.

4-12. Power Supply Tests (Continued)

TABLE 4-3  
POWER SUPPLY VOLTAGE CHECKS

LOCATION		Nominal Voltage (VDC)	Limits (VDC)
Test Point	Common		
P1-12	P1-13	+17.3 Unreg.	+16.3 to +18.3
ATP-12	P1-13	-20.0 Unreg.	-19.0 to -21.0
P1-10	P1-13	+12.0 Reg.	+12.0 to +12.6
P1-11	P1-13	-12.0 Reg.	-11.4 to -12.6
P1-23	P1-13	+ 5.0 Reg.	+4.75 to +5.25
P1-9	P1-13	+ 380	+340 to +400

4-13. Preamplifier Tests. After completing initial setup of paragraph 4-11, proceed as follows to accomplish preamplifier testing (PCB 800101). Refer to Figure 3-3 for a schematic drawing of the Preamplifier Board.

1) Common Mode Rejection

- a) Set the function generator to obtain a 5 volt peak-to-peak amplitude at 60 Hz.
- b) Connect one side of the function generator to Iso ground on Preamplifier PCB (800101) (J1, pin 6 or pin F on the patient lead connector).
- c) Short the Wht, Blk, Red, and Brown leads together and connect to the other side of the function generator.
- d) Adjust the LEAD SELECT switch to II and depress POWER switch on.
- e) Verify that there is less than 500 mv peak-to-peak output signal on the 1V/mv output jack at rear of instrument.
- f) Adjust R33 on preamplifier PCB for a minimum signal on the 1V/mv output.
- g) Adjust the LEAD SELECT switch to other lead positions and verify that the signal is less than 500 mv on the output jack.

2) Gain

- a) Set the function generator for 1 mv peak-to-peak amplitude at 10 Hz.
- b) Connect the function generator to the patient cable between the Wht and Red leads.

4-13. Preamplifier Tests (Continued)

- c) Adjust the LEAD SELECT switch to position II. Verify that there is 1 volt peak-to-peak output on the 1V/mv output jack.
- d) Depress POWER switch off.

3) 60Hz Notch Filter

- a) Set the function generator for a 1mv peak-to-peak at 60Hz differential signal.
- b) Connect the function generator to the paddles input on the Preamplifier PCB (J2-1 and J2-3).
- c) Adjust the LEAD SELECT switch to PADDLES.
- d) Connect an oscilloscope to the 1V/mv output and adjust R54 on the Preamplifier PCB for a 60Hz null not to exceed 10mv peak-to-peak.

4-14. No-Fade and Deflection Amplifier Adjustments. After completing the initial setup of paragraph 4-11, proceed as follows to accomplish the No-Fade and Deflection Amplifier Adjustments. Refer to Figure 3-9 and Figure 3-13 for the schematics relative to the following procedure.

1) Clock Frequency Adjust

- a) Place the No-Fade Board (800159) on an extender board.
- b) Verify that the LEAD SELECT switch is on the STD position, and the ECG SIZE control is fully ccw.
- c) Connect the oscilloscope (1 megohm probe) to U9, pin 10.
- d) Depress POWER switch on. Verify clock frequency is 350 KHz to 400 KHz. If not, adjust R2 on the No-Fade PCB.
- e) Remove the oscilloscope connections.

2) Baseline Offset

- a) Adjust R39 (on No-Fade PCB), intensification adjust, to the fully counterclockwise position.
- b) Set the DVM to read 200 mv DC full scale. Connect the DVM between U20, pin 10 and ground.
- c) Adjust R24 (on No-Fade PCB), baseline offset, for a  $0V \pm 10mv$  output.

3) CRT Deflection and Brightness Adjustment

- a) Connect the function generator between the white and red leads of the patient cable.
- b) Adjust the function generator to obtain a 1 Hz square wave with an amplitude of 1 mv.
- c) Adjust the LEAD SELECT switch to LEAD II.
- d) While observing the cardioscope, adjust R19, gain control, and R21 linearity, (on the Power Supply/Deflection PCB 800112), so that with 4 cycles displayed in the FREEZE mode, there is  $25 \text{ mm} \pm 1 \text{ mm}$  between peaks.

Note: The gain adjustment of R19 controls the CRT distance between square wave signals while the R21 linearity adjustment makes the distance constant as the signal moves across the CRT.

4-14. No-Fade and Deflection Amplifier Adjustments (Continued)

3) CRT Deflection and Brightness Adjustments (Continued)

- e) Set the function generator to obtain a 5 Hz sinewave with an amplitude of 1 mv.
- f) Adjust the ECG SIZE control on instrument panel for a 1/2 inch peak-to-peak deflection on the CRT. Adjust R5, intensity control (on the Power Supply/Deflection Amplifier PCB), for adequate brightness on the CRT in a brightly lighted room.

CAUTION

Oscilloscope face may be damaged permanently if trace is too bright.

4) R-wave Intensity Calibration

- a) Connect Heart Simulator to the patient cable. Adjust the LEAD SELECT switch to LEAD II.
- b) Adjust the ECG SIZE control for 25 mm deflection on the CRT.
- c) Adjust the R38, intensification adjust, (on the No-Fade PCB), so that the R-wave and baseline are near equal intensity.
- d) Depress POWER switch off.
- e) Remove the No-Fade PCB from the extender and plug board back in instrument.

4-15. Rate Meter and Rate Alarm Calibration. After completing the initial setup of paragraph 4-11, proceed as follows to accomplish the rate meter and rate alarm calibrations. Refer to Figure 3-6 for a schematic drawing of Rate Board.

- a) Adjust the function generator to produce a 40 ms square-wave pulse with a 1 mv amplitude as shown below.

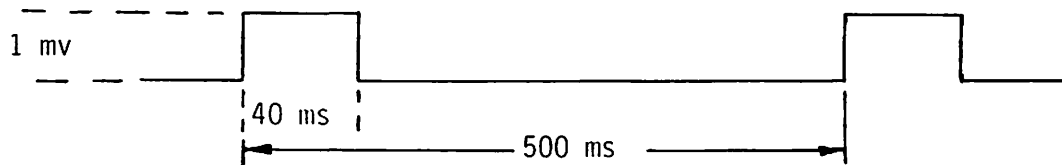

- b) Connect function generator to patient cable White and Red leads. Adjust LEAD SELECT switch to II.
- c) Adjust HEART RATE high limit alarm to 120 BPM.
- d) Depress POWER switch on.
- e) With the QRS volume control adjusted clockwise approximately 1/4 turn, adjust R45, on the Rate Board (800053), until systole alarm sounds.

Note: The ECG SIZE control may have to be increased slightly.

4-15. Rate Meter and Rate Alarm Calibration (Continued)

- f) Turn the HEART RATE high limit alarm to the off position.
- g) Adjust R52, on the Rate Board (800053) until the HEART RATE display reads  $120 \pm 4$  BPM.
- h) Check display accuracy by changing the repetition time of signal from the signal generator, as shown in diagram of item (a), to the values listed below. Observe the Heart Rate display.

<u>Repetition Time</u>	<u>Heart Rate Display</u>
2000 ms	$30 \pm 3$ BPM
250 ms	$240 \pm 8$ BPM

1) Systole Sound

- a) Set function generator for a repetition time of 1000 ms (60 BPM).
- b) With the QRS volume control set at minimum, the systole alarm should be inaudible.
- c) Turn the QRS volume control clockwise until audible. The systole beep should be audible at the rate of one beep per second and should correspond to the pulses observed on the Cardioscope.
- d) Depress POWER switch off. Remove the function generator from the patient cable.

4-16. Frequency Response Test. After completing initial setup of paragraph 4-11, proceed as follows to accomplish the frequency response test.

1) Recorder Real Time

- a) Adjust the function generator to produce a 10 Hz, 1 mv sinewave.
- b) Connect the function generator to the patient cable White and Red leads. Adjust the LEAD SELECT switch to position II.
- c) Depress POWER switch on. Adjust the Recorder DELAYED-OFF-REAL switch to the REAL position.
- d) Adjust the ECG SIZE control for a 5 mm P-P display on the recorder.
- e) Verify the frequency response of the recorder with the function generator adjusted to 1, 10, 20, 40, 60, 80 and 100 Hz. Recorder amplitude should remain constant through 50 Hz and begin to roll off to 3.5 mm P-P minimum at 100 Hz.
- f) Adjust the Recorder DELAYED-OFF-REAL switch to the OFF position.

4-16. Frequency Response Test (Continued)

2) 1V/mv ECG Output

a) Repeat item 1 above while observing the ECG OUT jack using the oscilloscope probe.

3) Recorder Delay Time

a) Adjust the Recorder DELAYED-OFF-REAL switch to the DELAYED position.

b) Adjust the function generator to produce a 10 Hz, 1 mv sinewave. Adjust the ECG size control for a 10mm P-P display on the recorder.

c) Verify the frequency response of the recorder with the function generator set to 1, 10, 20, and 40 Hz. Recorder should roll off at approximately 20 Hz and should be 7 mm P-P minimum at 40 Hz.

d) Adjust the Recorder DELAYED-OFF-REAL switch to the OFF position.

4) CRT Frequency Response

a) Repeat item 3 above while observing the cardioscope.

b) Cardioscope should be 7 mm P-P at 30 Hz.

c) Depress the POWER switch off.

4-17. Size Control Test. After completing initial setup of paragraph 4-11, proceed as follows to accomplish the Size Control Test.

1) ECG Gain Test

a) Adjust the function generator to produce a 10 Hz sinewave with an amplitude of 1 mv.

b) Adjust the LEAD SELECT switch to position II.

c) Connect the function generator between the White and Red leads of the patient cable.

d) Depress POWER switch on.

e) With the oscilloscope probe connected to the ECG OUT jack, verify that the 1V output is 1 volt P-P and the 1 mv output is 1 mv P-P.

Note: The accuracy of this measurement depends on the accuracy of the 1 mv P-P input.

2) CRT Size Test

a) With the instrument operating as in item 1 above, adjust the ECG SIZE control to minimum. Verify that the CRT signal displayed is 1 mm to 3 mm.

b) Adjust the ECG SIZE control to maximum and verify that the signal displayed is 4 cm to 6 cm P-P.

4-17. Size Control Test (Continued)

3) Recorder Size Test

- a) With the instrument operating as in item 1 above, adjust the ECG SIZE control to produce a 3 cm P-P signal on the CRT.
- b) Adjust the Recorder DELAYED-OFF-REAL switch to REAL. Verify that the signal produced is  $1.7 \text{ cm} \pm 0.2 \text{ cm P-P}$ .
- c) Adjust the Recorder DELAYED-OFF-REAL switch to DELAYED. Verify that the signal produced is  $1.7 \text{ cm} \pm 0.2 \text{ cm P-P}$ .
- d) Adjust the Recorder DELAYED-OFF-REAL switch to OFF.
- e) Depress POWER switch off.

4-18. Monitor Charger Board Tests. After completing the initial setup of paragraph 4-11, proceed as follows to accomplish the Monitor Charger Board Tests. Refer to Figure 3-14 for a schematic drawing of the Charger Board (800157).

1) Battery Charge Current and AC Rectified Voltage Check

- a) Connect a DC ammeter (500 mA range) in series with the positive battery lead and battery terminal.
- b) Connect the AC power cord to the AC power source. Depress POWER switch on.
- c) Verify that the battery charge current is approximately 150 mA DC and the BATT CHG indicator is illuminated.
- d) With the DMM, measure the positive voltage at J2-1 with respect to ground (negative terminal of battery). Verify that the voltage is  $+18.6 \pm 1.0 \text{ VDC}$ .
- e) Depress POWER switch off. Disconnect the AC power cord from the AC power source.
- f) Disconnect the DC ammeter.

2) Battery Level Meter Calibration

- a) Disconnect the battery leads to the battery.
- b) Connect a DC power supply between the positive battery lead and the negative battery lead.  
  
Note: Be careful, observe proper polarity.
- c) Adjust the power supply to provide 13.8 VDC.
- d) Adjust R3, on the Charger Board, for an indication of mid-scale (Red-Green interface) reading on the BATT LEVEL meter on instrument front panel.

4-18. Monitor Charger Board Tests (Continued)

2) Battery Level Meter Calibration (Continued)

- e) Depress POWER switch to off. Disconnect the AC power cord from the AC power source and the DC power supply.
- f) Reconnect the battery leads to the battery.

4-19. 1 mV CAL Test

- a) Connect the oscilloscope probe to the 1 volt ECG OUT jack.
- b) Depress POWER switch on. Adjust the LEAD SELECT switch to STD position.
- c) Depress the 1 mV CAL button and verify that the 1V ECG OUT is  $1V \pm 0.1V$  P-P.
- d) Depress POWER switch to OFF.

4-20. Lead Select Tests

1) Lead Select Verification

- a) Adjust the function generator to produce a square-wave pulse in accordance with paragraph 4-15(a).
- b) Depress the POWER switch on.
- c) Verify the appearance of signals on the CRT, in all lead configurations per Table 4-4.

TABLE 4-4  
LEAD SELECT VERIFICATION TEST

LEAD SELECT switch position	Function Generator Connections to Patient Cable
I	White - Black
II	White - Red
III	Black - Red
AVR	Black & Red - White
AVL	White & Red - Black
AVF	White & Black - Red
V	Red, White & Black - Brown



#### 4-20. Lead Select Tests (Continued)

##### 2) R-wave Detector Verification

- a) Connect signal generator, operating as above, between White and Red leads of patient cable.
- b) Adjust the LEAD SELECT switch to position II.
- c) Adjust the ECG SIZE control to produce a 2 cm signal on CRT. Verify that the systole indicator flashes on the rate display.
- d) Depress POWER switch to off. Disconnect the signal generator from the patient cable.

#### 4-21. Offset Check

- a) Adjust the function generator to produce a 1 mv p-p, 10 Hz signal. Connect the function generator to a DC power supply and patient cable as shown in Figure 4-2.
- b) Adjust the power supply to produce + 1 VDC and turn off.
- c) Depress the POWER switch on and adjust the ECG SIZE control for a 3 cm p-p trace on the cardioscope (CRT). Switch the power supply on and observe trace on CRT. Verify that the trace returns to the CRT center line within 3 seconds.
- d) Turn power supply off and reverse power supply terminals to produce a -1 VDC signal. Repeat step (c) above.

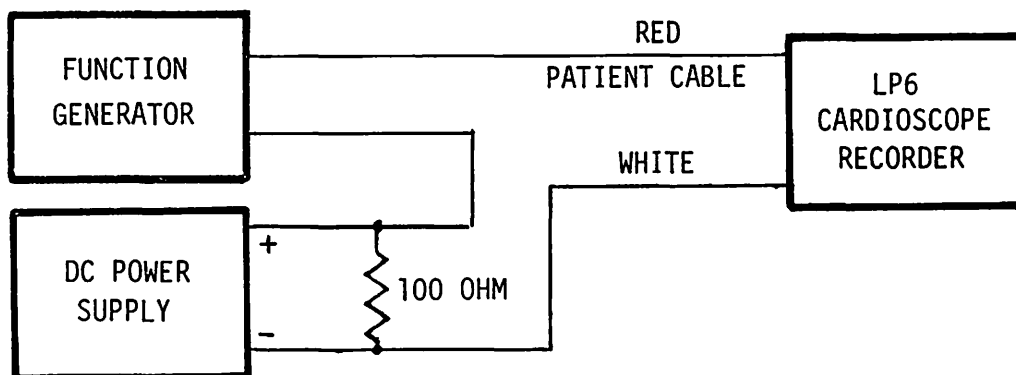

Figure 4-2. Offset Check Setup

#### 4-22. Leakage Test

- a) Verify that the POWER switch is off, and the AC power cord is disconnected from the AC power source.
- b) Using a multimeter, measure the resistance between the ground wire of the AC power cord and the patient connector shell. Verify that the resistance is greater than 20M ohms.

4-22A. Recorder Assembly Adjustments. Remove the recorder assembly from the cardioscope/recorder module in accordance with paragraph 4-31, "Recorder and PCB Assembly Removal".

- a) After completing the removal of recorder assembly from the cardioscope/recorder module, place the recorder assembly on a level surface with the gear side down. (See below).

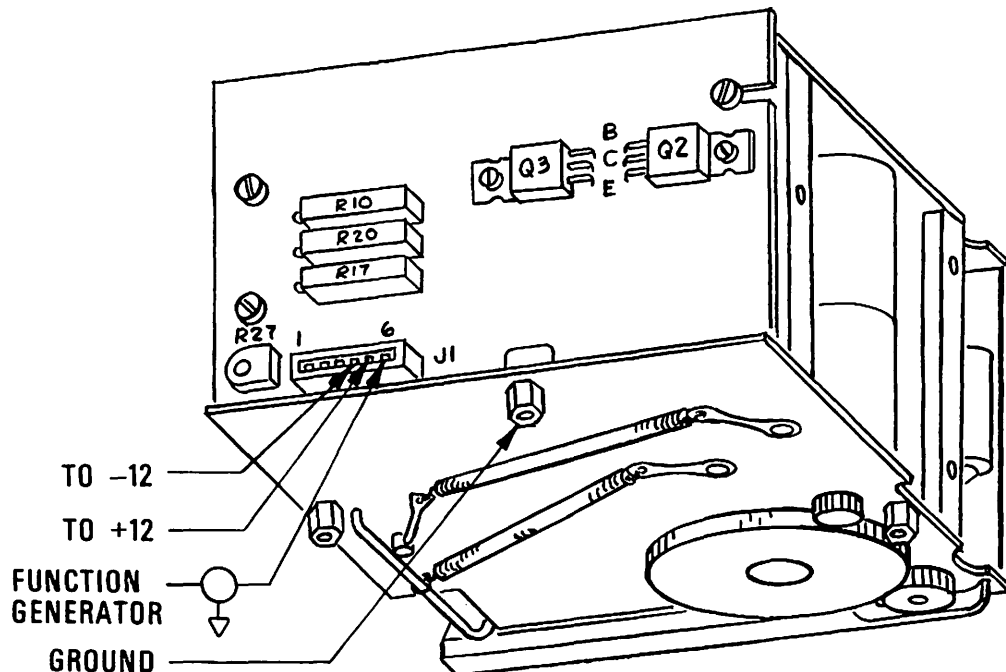

- b) Set the DC power supply to obtain  $\pm 12\text{VDC}$ .
- c) With the DC power supply off, connect minus (-) lead to pin 4 and the positive (+) lead to pin 5 of J1. Connect the ground lead to the hex stud as shown in diagram above.
- d) Set the function generator to obtain a  $1\text{ Hz} \pm 0.1\%$  square wave input. Connect one side of the function generator to ground as shown in the diagram above.
- e) Connect the other side of the function generator to pin 6 of J1.
- f) Turn the DC power supply on, and adjust the function generator for an amplitude of  $10\text{mm P-P}$  on the recorder paper.
- g) Adjust R20 (on recorder board) for a paper speed of  $25\text{mm/sec} \pm 0.5\text{mm}$ . Turn power supply off.
- h) Connect the oscilloscope probe to the collector of Q2 (on recorder board). Turn DC power supply on and verify that the initial stylus heat pulse is 1 second.

4-22A. Recorder Assembly Adjustments (continued)

- i) Adjust R27, stylus heat (on recorder board) for a 25% duty cycle at 10VDC on the oscilloscope.

Example:

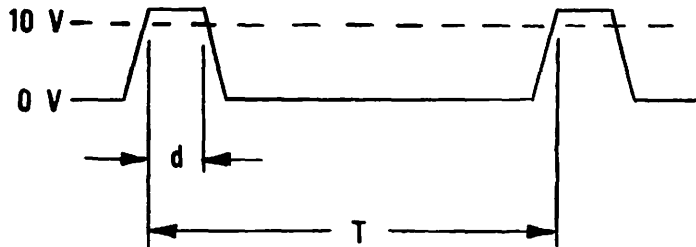

$$\begin{aligned} \text{DUTY CYCLE} &= \frac{d}{T} \times 100\% \\ &= \frac{7.5 \mu\text{S}}{30 \mu\text{S}} \times 100\% \\ &= 25\% \end{aligned}$$

- j) With recorder running, adjust the stylus pressure for 6 to 8 grams.
- k) Adjust the function generator for a 10mm P-P square wave input at 1 Hz on the recorder paper. Adjust R10 (on recorder board) for minimum over/undershoot.
- l) Adjust the function generator for a 10mm P-P sine wave on the recorder paper at 3 Hz.
- m) Change the frequency to 50Hz and adjust R17 (on recorder board) for a 10.1 to 10.3mm P-P on the recorder paper.
- n) Repeat steps (k) thru (m) for optimum adjustment of R10 and R17 (on the recorder board).
- o) Set the function generator for 10mm P-P at 25Hz. Check the frequency response on the recorder paper from 0.5Hz to 50Hz. Verify that the response is 10mm  $\pm$  0.6mm P-P.
- q) Set the function generator for 5mm P-P at 25Hz. Check the frequency response on the recorder paper from 0.5Hz to 100Hz. Verify that the response is 5mm  $\pm$  0.3mm P-P from 0.5Hz to 50Hz and decreases linearly from 50Hz to 100Hz. Amplitude at 100Hz should not be less than 3.5mm P-P.

#### 4-23. Major Component Removal and Installation (Cardioscope/Recorder)

The following procedures of paragraphs 4-24 through 4-37 provide the sequence for removing and installing the major components of the cardioscope/recorder.

Note: Disassembly should always be accomplished with the AC power cord disconnected from the wall outlet.

Installation is for the most part the opposite of removal so only the removal procedures are provided. Special installation notes as required are provided as part of the removal or disassembly procedure. Remove or disassemble only to the point required. Figure 4-3 provides an exploded view of cardioscope/recorder to assist in the following procedure.

#### CAUTION

Use the Removal Tool-Flex Circuit (see Table 4-1) when removing the printed flex circuit (PCF) from connectors. Non-repairable damage to the flex circuit may occur if this tool is not used.

#### 4-24. Access Cover Removal. Refer to Figure 4-3 and proceed as follows:

Note: Installation procedures at this point are essentially the reverse of the removal procedure.

- 1) Position module so that upper part of case is down.
- 2) Remove eleven screws ① securing cover ② to case ③.
- 3) Lift cover ② up slightly and disconnect the two connectors.
- 4) Lift cover ② off and lay aside. At this point the module is in the test configuration.
- 5) If further disassembly is required, proceed to the following paragraphs.

#### 4-25. No-fade Board (PCB) Removal. After completing procedures in paragraph 4-24 proceed as follows:

Note: Installation of no-fade board is essentially the reverse of the removal procedure.

Remove no-fade board ④ by simply lifting the board up and out of the card guides.

#### 4-26. Rate Board (PCB) Removal. After completing procedures in paragraph 4-24 proceed as follows:

Note: Installation of the Rate Board (PCB) is essentially the reverse of the removal procedure.

- 1) Lift the rate board ⑤ up slightly and disconnect the ribbon cable connector ⑥ from board.
- 2) Lift rate board ⑤ up and out of the card guides.

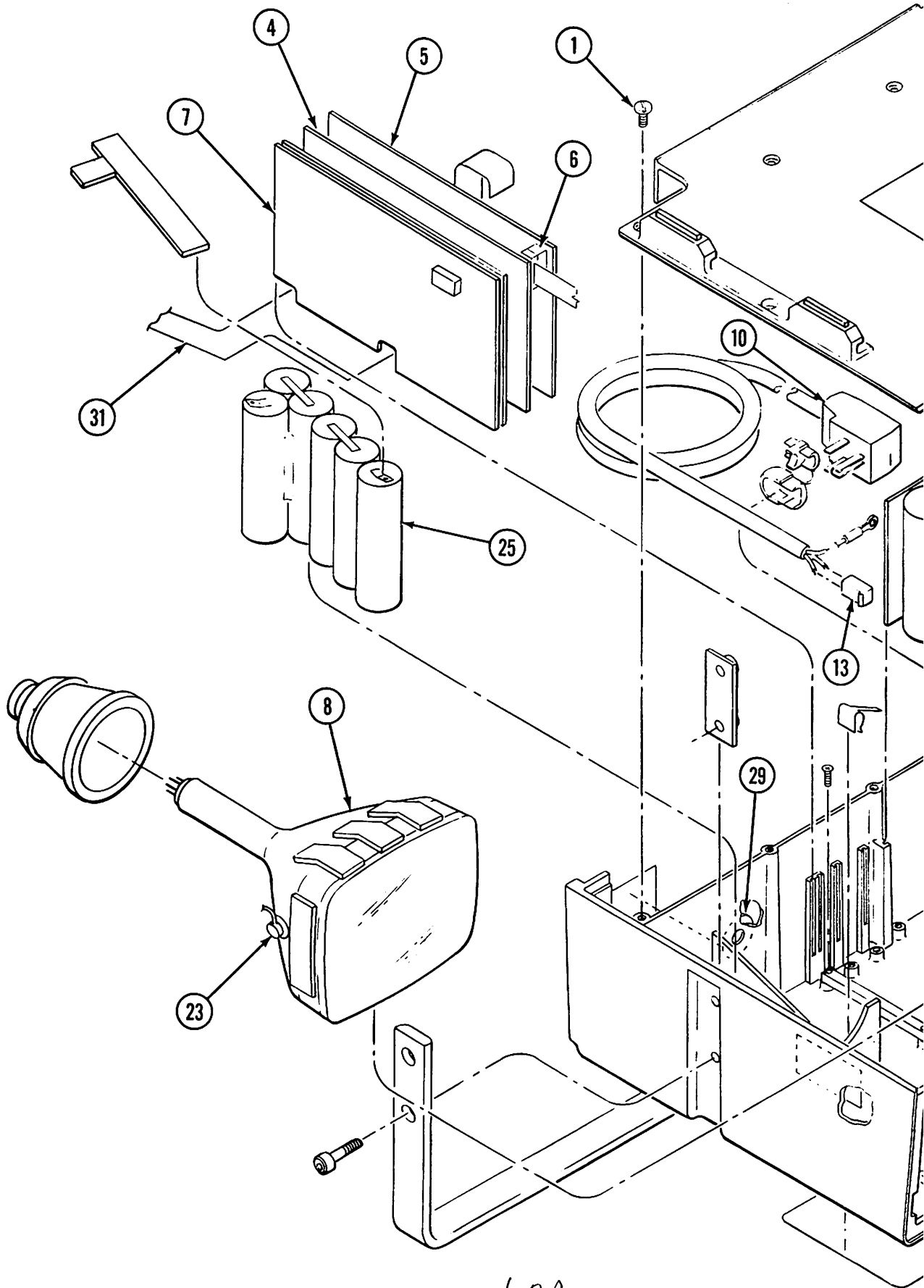

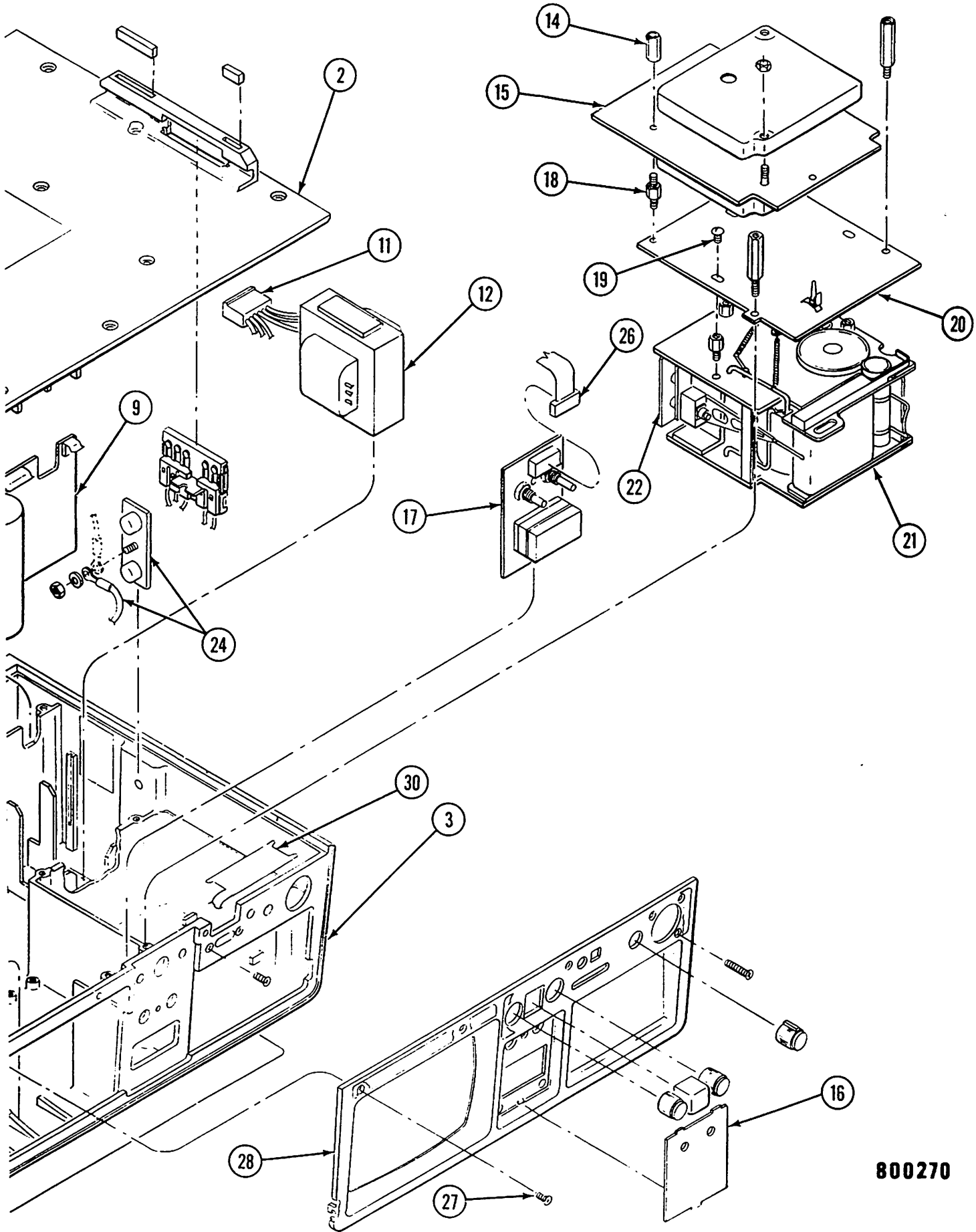

800270

Figure 4-3. Cardioscope/Recorder Major Component Removal

4-20/4-21

4-21

4-27. Power Supply Board (PCB) Removal. After completing procedures in paragraph 4-24 proceed as follows:

Note: Installation of the power supply board is essentially the reverse of the removal procedure.

- 1) Disconnect the yoke connector from the power supply board (7). Disconnect the anode connector (23) at the CRT (8).
- 2) Lift the power supply board (7) up and out of card guides.

Note: It may be necessary to raise the CRT (8) up slightly to allow the anode lead wire to clear CRT assembly.

4-28. Charger Board (PCB) Removal. After completing the procedures of paragraph 4-24 proceed as follows:

Note: Installation of the charger board (PCB) assembly is essentially the reverse of removal procedure.

- 1) Disconnect the power cord assembly connector (13) and transformer assembly connector (11) from the charger board (9).
- 2) Remove the charger board (9) by lifting the board up and out of the card guides.

4-29. Preamp Board (PCB) Removal. After completing the procedures in paragraph 4-24 proceed as follows:

Note: Installation of the preamp board is essentially the reverse of the removal procedures.

- 1) Remove two rear standoffs (14) and detach the forward plastic retaining clip.
- 2) Lift the preamp board (15) up slightly and remove the two flex circuit connectors.
- 3) Remove the preamp board (15) by lifting up and out of instrument.

4-30. Display Board (PCB) Removal. After completing the procedures in paragraph 4-24 proceed as follows:

Note: Installation of the display board is essentially the reverse of the removal procedures.

- 1) Remove the (optional) rate limit alarm adjustment knobs and disconnect flex cable connector (26) from board.
- 2) Remove front panel (16) and one mounting screw behind panel from instrument.
- 3) Move the display board (17) assembly back and then lift the assembly up and out of the instrument.

4-31. Recorder and PCB Assembly Removal. After completing the procedures in paragraph 4-24 proceed as follows:

Note: The procedures in paragraph 4-29, Preamp Board (PCB) Removal, must be completed first before attempting to remove the Recorder and PCB assembly.

- 1) Remove four standoffs (18) and three mounting screws (19).
- 2) Remove the ground wire (24) and recorder mounting plate (20).
- 3) Lift the recorder assembly (21) up slightly at the rear and remove flex circuit from the connector attached to recorder PCB (22).
- 4) Lift the rear of the recorder assembly (21) up first and then slide assembly up at an angle and out of the instrument case.

Note: Installation of the recorder and PCB assembly is essentially the reverse of the removal procedure.

4-32. Cardioscope (CRT) Removal. After completing the procedures of paragraph 4-24 proceed as follows:

Note: Installation of the cardioscope (CRT) is essentially the reverse of the removal procedure.

- 1) Disconnect the main flex circuit connector from rear of CRT (8).
- 2) Remove the anode lead (23) from CRT (8).
- 3) Lift the rear of the CRT (8) up slightly and move CRT back clearing the case mounting bosses; then remove CRT (8) up and out of the instrument.

4-33. Power Cord Assembly Removal. After completing the procedures of paragraph 4-24 proceed as follows:

Note: Installation of the power cord assembly is essentially the reverse of the removal procedure.

- 1) Disconnect the power cord assembly connector (13) from the charger board (9).
- 2) Disconnect the ground lug from attachment plate (24).
- 3) Lift power cord assembly (10) up and out of the instrument. (Strain relief assembly comes off with power cord assembly).

4-34. Transformer Assembly Removal. After completing the procedures of paragraph 4-24 proceed as follows:

Note: Installation of the transformer assembly is essentially the reverse of the removal procedure.



4-34. Transformer Assembly Removal (Continued)

- 1) Remove connector (11) from the charger board (9).
- 2) Lift transformer assembly (12) up and out of instrument case.

4-35. Battery Removal. After completing the procedures of paragraph 4-24 proceed as follows:

Note: Installation of the battery pak is essentially the reverse of the removal procedure.

To remove battery pak (25) simply lift assembly up and out after disconnecting the slide-on wire lugs connected to the terminals.

4-36. Control Flex Cable Removal. After completing the procedures of paragraph 4-24 proceed as follows:

Note: Installation of the control flex cable assembly is essentially the reverse of the removal procedure.

- 1) The removal procedures for the Rate Board, paragraph 4-26, and the No-Fade Board, paragraph 4-25, must be accomplished before the following procedure can be performed.
- 2) Remove foam pad behind the BATT level indicator.
- 3) Remove the control and logo labels.
- 4) Remove the control knobs from the following controls; LEAD SELECT switch; ECG VOL/1mV switch; ECG SIZE and FREEZE switch; and the POWER switch.
- 5) Remove two mounting screws on the recorder REAL/DELAYED power switch.
- 6) Remove eight screws (27) around bezel (28).

CAUTION

DO NOT FORCE BEZEL OUT OF THE CASE. The plastic protrusions at the bottom of the bezel could be damaged.

- 7) Tilt the upper end of the bezel, with respect to the instrument being upside down, out slightly forward and lift the bezel assembly out of the instrument case at an angle.
- 8) Remove the mounting hardware from the following controls; LEAD SELECT switch; ECG VOL/1mV switch; ECG SIZE and FREEZE switch; and the POWER switch.
- 9) Disconnect the flex connector to the main flex cable (31) assembly near the rate PCB (5) location.

4-36. Control Flex Cable Removal (Continued)

- 10) Remove the control flex cable (30) from the double backed tape located on the inner case recorder wall. Lift the control flex cable (30) from the instrument.

4-37. Main Flex Cable Removal. After completing the procedures of paragraph 4-24 proceed as follows:

Note: Installation of the main flex cable assembly is essentially the reverse of the removal procedure.

- 1) The removal procedures for the Power Supply PCB, paragraph 4-27, the Rate PCB, paragraph 4-26, and the No-Fade PCB and Charger PCB, paragraphs 4-25 and 4-28, respectively, must be performed before the following procedures can be accomplished.
- 2) Remove the ECG connector (29) mounting nut and washer.
- 3) Disconnect the flex circuit connector from rear of CRT (8).
- 4) Remove two slide-on wire lugs connected to the battery terminals.
- 5) Remove eight mounting screws which secure the PCB card edge connectors to case.
- 6) Remove the ground screw (24) and wire attached.
- 7) Lift out the main flex cable (31) assembly.

4-38. DC DEFIBRILLATOR MODULE

The following paragraphs 4-39 through 4-53 provide maintenance procedures for the DC Defibrillator and are divided into three topics: troubleshooting, test and calibration, and major component removal and installation.

Figure 4-5 provides an overall view of the DC Defibrillator module with key components and test points or adjustments indexed to a legend.

- 4-39. Troubleshooting. Troubleshooting should start with observing for obvious symptoms such as odors from overheated components, or mechanical malfunctions. Use Table 4-5, DC Defibrillator Module Troubleshooting Guide, to isolate specific malfunctions. Refer to paragraph 4-51 for procedure for major component removal and installation.

WARNING

TERMINALS AND WIRES CARRYING HIGH VOLTAGES ARE EXPOSED WITH THE LIFEPAK 6 COVERS REMOVED. OBSERVE SAFE WORKING TECHNIQUES. BE CAREFUL DURING TROUBLESHOOTING, TESTS AND CALIBRATION OR COMPONENT REMOVAL AND INSTALLATION.

TABLE 4-5  
DC DEFIBRILLATOR TROUBLESHOOTING GUIDE

MALFUNCTION	POSSIBLE CAUSE	CORRECTIVE ACTION
<p>1. Unit does not function when POWER (I) switch is depressed.</p>	<p>a. Defective fuses on Main PCB</p>	<p>a. If 10 amp fuse only. Check for defective CR1, CR10, CR18 or Q1 on main PCB.</p> <p>If 3/8 amp Fuse only. Check for defective CR15, U4, U5, U6, U2 on main PCB.</p>
	<p>b. Battery discharged below minimum operating level.</p>	<p>b. Operate unit on AC power. Check BATT CHG indicator illumination. Check for output from Charger PCB at P1, pins 1 &amp; 2 with battery disconnected. Check for Charger PCB for defective components Q5, Q6, Q7 or CR13.</p>
	<p>c. Defective Converter Circuitry (K1 operates but no DC voltage to main PCB).</p>	<p>c. Check for defective Q1, Q2, Q3, Q4, CR7-CR10, CR14-CR17, R3 and R4 on Charger PCB.</p>
	<p>d. Defective ON/OFF Circuitry.</p>	<p>d. Check main PCB for defective K1 (on/off relay), U1, U3, U5, or Q3.</p>
<p>2. Unit fails to stop Charging at energy level selected.</p>	<p>a. Energy Select circuitry defective (includes comparator circuit, and Stop circuits).</p>	<p>a. Check resistor network on flex circuit.</p> <p>Check for defective R1, RN3, U4 and U6 on main PCB. Check circuit continuity from Control panel to main PCB.</p>
<p>3. Unit fails to remain Ready after charge.</p>	<p>a. Defective Dump Relay circuit.</p>	<p>a. Check for defective U4, U5, and CR4 on main PCB.</p>

TABLE 4-5  
DC DEFIBRILLATOR TROUBLESHOOTING GUIDE (CONTINUED)

MALFUNCTION	POSSIBLE CAUSE	CORRECTIVE ACTION
4. Unit fails to transfer energy after charge.	a. Defective transfer circuitry.	a. Check for defective U3, U4, Q2, or CR3 on main PCB. Check paddle discharge transfer switch. Check paddle interlock continuity.
5. Unit does not charge when CHARGE switch is depressed.	a. Battery below operating limit.	a. Recharge battery.
	b. ENERGY SELECT circuitry defective.	b. Check resistance network on flux circuitry.
	c. Open circuit on paddle interlock.	c. Check paddle connector engagement. Check interlock continuity.
	d. Charge switch circuitry defective.	d. Check charge switch continuity on front panel or paddles.
	e. Transfer Relay Defective	e. Check for continuity on relay charge contacts and wiring.
	f. Charge Command, flyback circuitry defective.	f. Check for defective RN3, U3, U4, U6, Q1, CR2, or T1 on main PCB.
6. Ready light on paddles does not light at any time (or on constantly).	a. LED defective.	a. Replace LED.
	b. Ready light circuitry defective.	b. Check for defective U4 or U6 on main PCB.
7. Bleed down time too short.	a. Energy select level not reached during charge.	a. Check for defective U4, C24, C4, RN3, CR16, or CR7 on main PCB.

TABLE 4-5  
DC DEFIBRILLATOR TROUBLESHOOTING GUIDE (CONTINUED)

MALFUNCTION	POSSIBLE CAUSE	CORRECTIVE ACTION
8. Charge time exceeds 10 seconds to reach 400 joule level.	a. Timing potentiometer out of calibration.	a. Perform charge timing test per paragraph 4-44.
	b. Energy level calibration potentiometer out of cal.	b. Check R7 calibration per paragraph 4-45.
	c. Battery below normal level (80% discharged).	c. Recharge battery. Use AC power.
9. Unit automatically charges when turned on.	a. Faulty charge control circuitry.	a. Check for defective U4, U6, or C22 on main PCB.
	b. Shorted CHARGE switch circuitry.	b. Check charge switch circuitry (Panel and Paddles).
10. Excessive noise when monitoring in Paddles mode. (ECG Quick-Look)	a. Transfer Relay ECG contacts faulty.	a. Replace Transfer Relay.
	b. ECG wiring faulty.	b. Check continuity.
	c. Interconnect Faulty.	c. Check Contact resistance.
11. Battery level meter not indicating or in error.	a. Meter Faulty.	a. Replace meter.
	b. Meter circuitry defective.	b. Check continuity of wiring and for defective R8, C17 or RN3 on main PCB.
	c. Calibration	c. Perform battery meter calibration per paragraph 4-43.
12. Test Load Indicator does not light at any energy level.	a. Faulty Test Load LED.	a. Replace LED.
	b. Defective Test Load Circuitry.	b. Check for defective Q1, Q2, or CR1 on test load PCB.
13. Unit fails to bleed down when energy select switch position is changed (Unit Charged).	a. Dump resistor open.	a. Replace Dump Resistor.
	b. Dump relay circuitry defective.	b. Check for defective U4 or U5 on main PCB.

TABLE 4-5  
DC DEFIBRILLATOR TROUBLESHOOTING GUIDE (CONTINUED)

MALFUNCTION	POSSIBLE CAUSE	CORRECTIVE ACTION
14. Unit fails to reach the higher energy levels.	a. Faulty Charge circuitry.	a. Check the waveforms at U6, pins 8 and 10 and the collector of Q1 on main PCB (see Figure 4-4).
	b. Leakage in dump relay.	b. Replace relay.

4-40. Tests and Calibration. Procedures given here are used to verify that the DC Defibrillator is operating within specifications. If the instrument is not functioning properly, locate the malfunction before attempting circuit calibration or adjustment. Refer to paragraph 4-7 for information concerning component location. Section IV provides the schematics and applicable test point waveforms and/or voltages.

4-41. Initial Control and Test Setup

- a) Disconnect the AC power cord from the external AC power source.
- b) Depress POWER 1 pushbutton switch and verify that the green power indicator is off.
- c) Separate the upper and lower case in accordance with paragraph 4-52.
- d) Fasten external paddles to energy meter (Table 4-1) electrodes.

CAUTION

HAZARDOUS VOLTAGE (5100 volts) IS ACROSS THE PADDLES ON DISCHARGE OR COULD BE PRESENT AS THE RESULT OF FAULTY CABLING OR CIRCUITRY. It is recommended that the paddles be fastened to the Energy Meter for all charge and discharge tests except for special requirements.

4-42. Current Drain. After completing initial setup of paragraph 4-41, proceed as follows to accomplish current drain testing. Refer to Figure 3-15 for schematic of the DC Defibrillator.

CAUTION

Replacing a blown fuse will often restore the unit to full capability. Nevertheless, replacing a blown fuse should always be followed by a careful check of the circuitry.

- a) Depress POWER 1 button and verify that the green power indicator is off indicating that power is removed.
- b) Connect a digital multimeter (20 ampere range) in series with P1, pin 4 on the charger board connector.

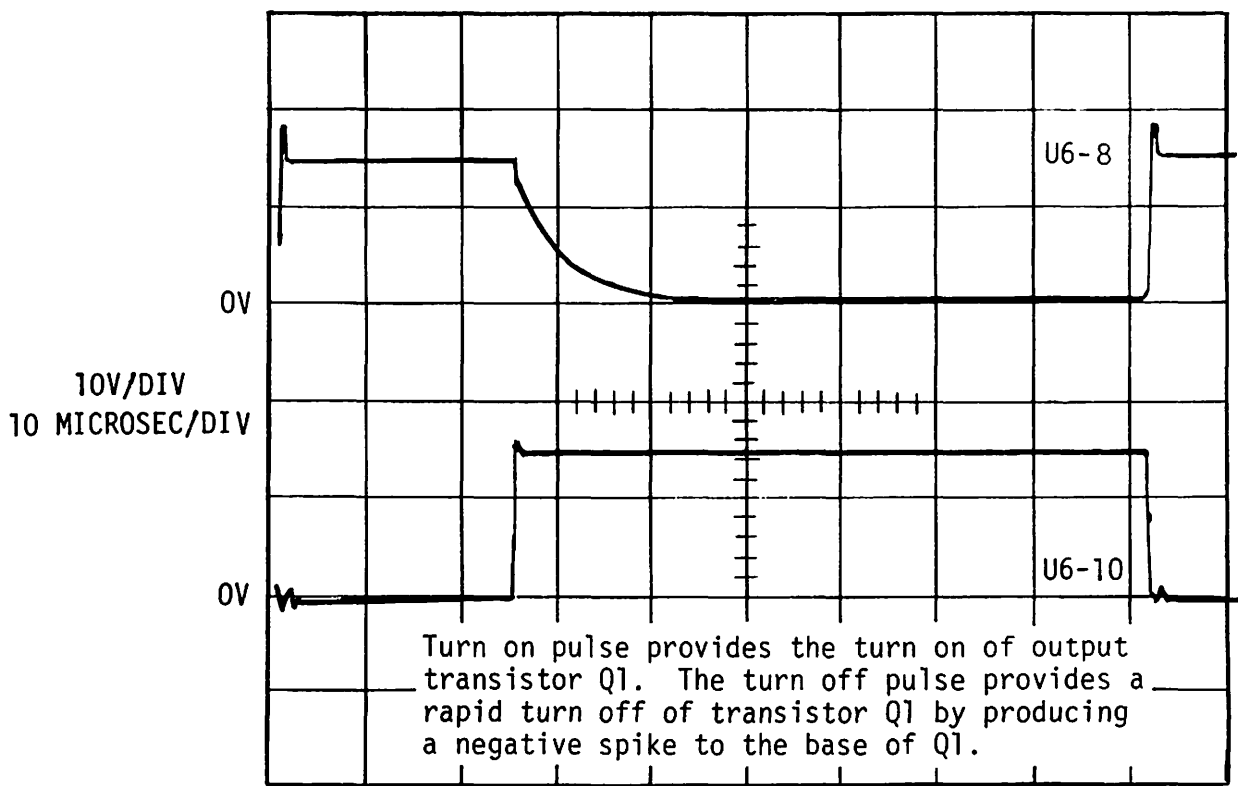
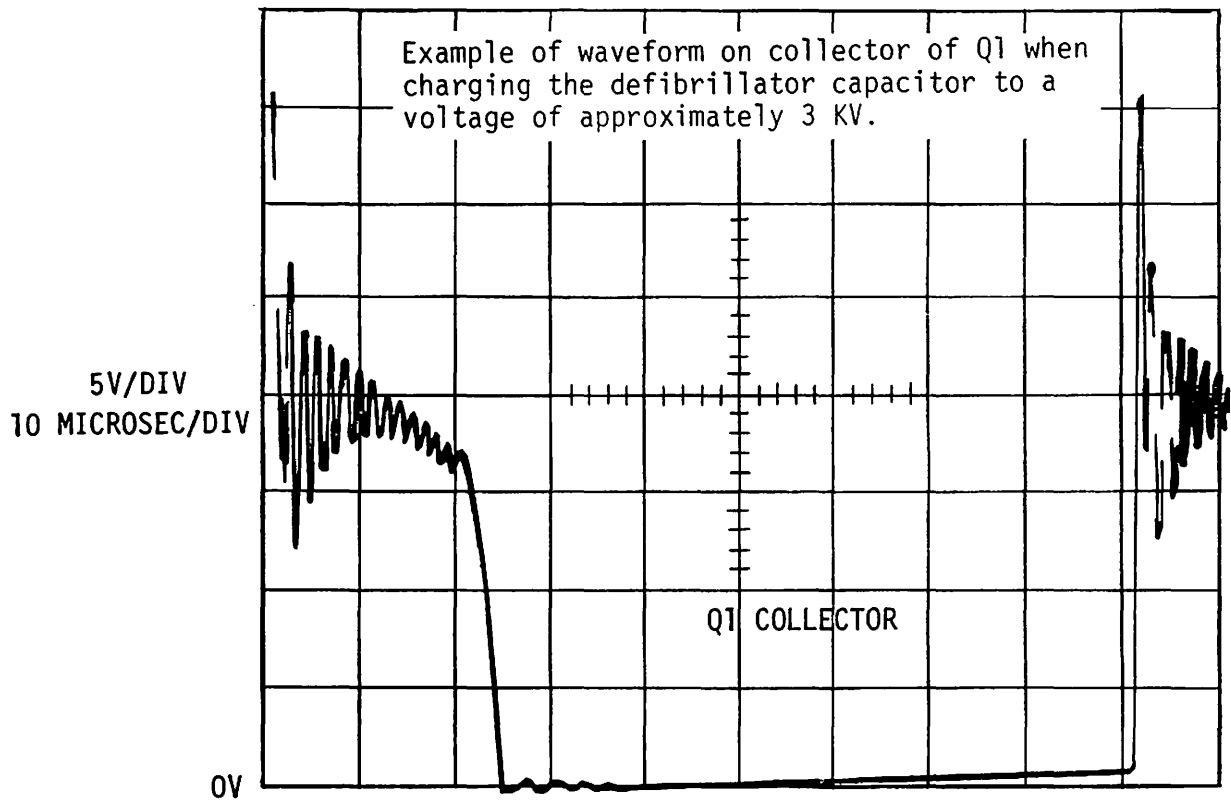

Figure 4-4. DC Defibrillator Key Voltage Waveforms

4-42. Current Drain (Continued)

- c) Depress POWER (1) button on and verify that the green indicator illuminates.
- d) Verify that the input current is between 100 - 120 ma DC.
- e) Set ENERGY SELECT (2) switch to 400 joules.

Depress and release the CHARGE (3) pushbutton while observing the digital multimeter. The current will continue to increase during the charge cycle until full charge is reached. At full charge it will drop back to minimum current. Verify the current does not exceed 10 amperes.

4-43. Battery Level Meter Test. After completing the initial setup of paragraph 4-41, proceed as follows to accomplish the battery level meter test.

- a) Connect the DC power supply (Table 4-1) across C15 on the main PCB. (Be sure to observe for proper polarity).
- b) Disconnect the Charger Board Connector from main flex assembly.
- c) Adjust the power supply to 10.5 VDC.
- d) Verify that the battery level indicator reads in the center of scale. If necessary, adjust R8 potentiometer on the main PCB.
- e) Disconnect the DC power supply and reconnect the Charger Board connector to main flex assembly.

4-44. Charge Circuitry. After completing the initial setup of paragraph 4-41, proceed as follows:

Note: Momentary pressure on the CHARGE (3) pushbutton switch starts the charge cycle. Once the defibrillator has charged to the desired level and the charge indicator stops flashing, the instrument is ready to fire. If not fired, the charge will slowly bleed down and when the charge has bled off to approximately 90% of the preselected level, the charge indicator will begin flashing and the instrument must be recharged before using.

- a) Connect the AC power cord to the external power source.
- b) Adjust the ENERGY SELECT (2) switch to 400 J.
- c) Momentarily Depress the POWER (1) switch to on and verify that the green indicator illuminates.
- d) Simultaneously start the stopwatch (Table 4-1) and press the CHARGE (3) pushbutton. Stop the stopwatch when the charge indicator ready light stops blinking.



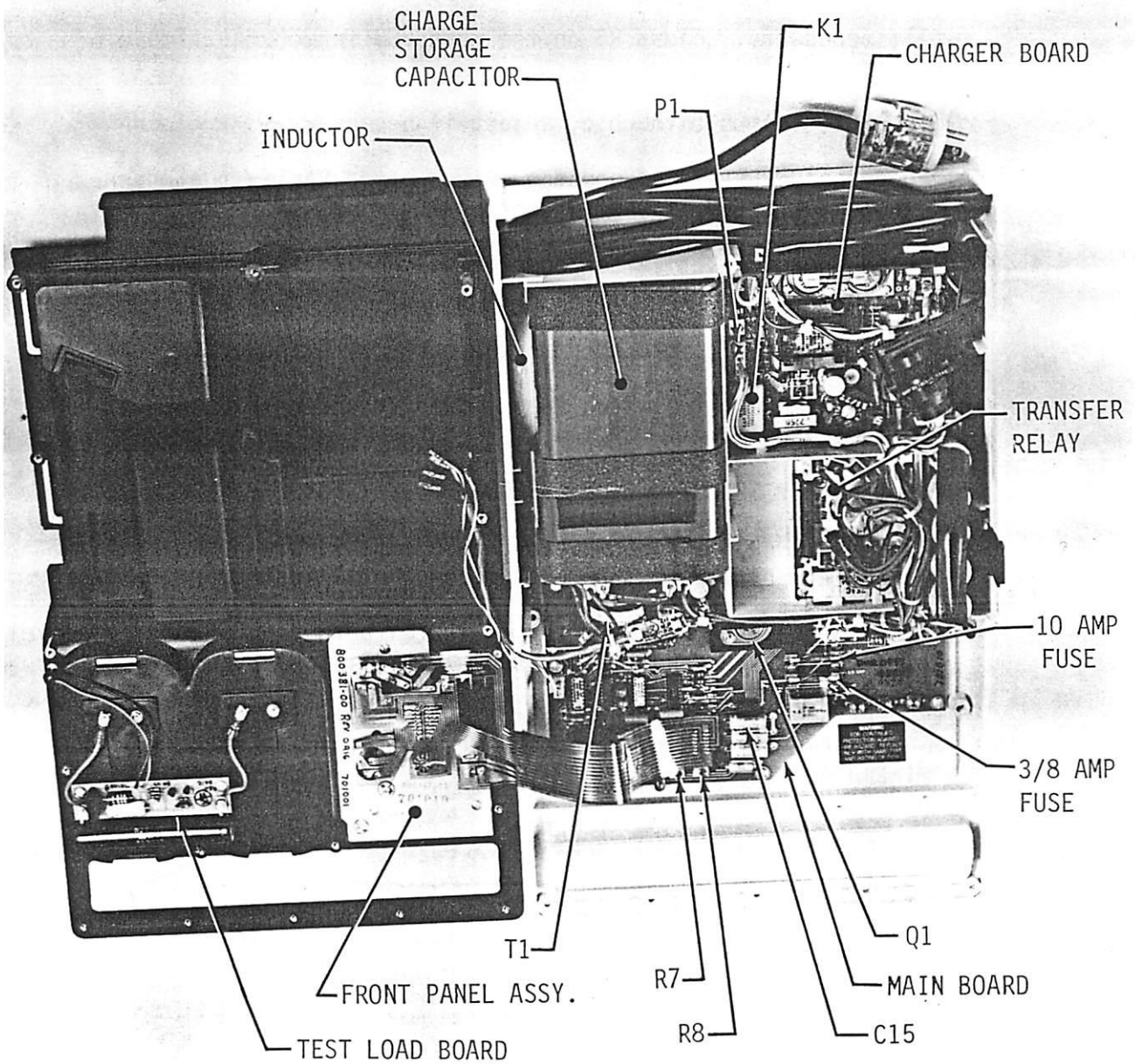

Figure 4-5. DC Defibrillator Module Component Identification

4-44. Charge Circuitry (Continued)

- e) Verify that the stopwatch reads less than 10 seconds (nominal 9.0 to 9.5 seconds). Depress both paddle discharge buttons simultaneously and verify energy is transferred to the energy meter.
- f) If necessary, adjust R6 on the main PCB for charge time of less than 10 seconds.
- g) Repeat steps b through e, adjust if necessary.
- h) Depress POWER ① pushbutton switch off. Verify the green indicator extinguishes.

4-45. Selected Energy Test. After completing the initial setup of paragraph 4-41, proceed as follows:

- a) Connect the AC power cord to the external AC power source.
- b) Depress POWER ① switch to on. Verify green indicator illuminates.
- c) Set ENERGY SELECT switch to 200J.
- d) Depress CHARGE ③ pushbutton, then immediately press both discharge buttons and hold them down until instrument discharges.
- e) Verify that the energy meter indicates between 188 and 212 joules. If necessary, adjust R7, on the main PCB, for 200 joules  $\pm$  12 joules.
- f) Repeat test on the other selectable energy levels and verify indication on energy meter is within the limits as noted in Table 4-6.

TABLE 4-6  
ENERGY SELECTOR TOLERANCES

ENERGY - JOULES	LIMIT (JOULES)
5	APPROX.
10	7 - 13
20	17 - 23
30	27 - 33
50	47 - 53
100	94 - 106
200	188 - 212
300	182 - 318
400	375 - 425
500 (optional)	470 - 530

4-45. Selected Energy Test (continued)

- g) Depress POWER ① switch off. Verify that the green indicator extinguishes.

4-46. Bleed Down. After completing the initial setup of paragraph 4-41, proceed as follows:

- a) Connect the AC power cord to the external AC power source.
- b) Depress POWER ① switch to on. Verify green indicator illuminates.
- c) Set the ENERGY SELECT switch to 400J.
- d) Depress the CHARGE ③ pushbutton switch and allow the instrument to charge. Start the stopwatch when the charge indicator ready light (on charge button) comes on steady. Stop the stopwatch when the charge indicator ready light starts blinking.
- e) Verify that the energy cannot be transferred and the bleed down time exceeds 30 seconds.
- f) Depress the CHARGE ③ pushbutton switch and verify transfer of energy when the charge indicator ready light is on steady.
- g) Depress POWER ① switch to off. Verify green indicator light extinguishes.

4-47. Output Waveform and Pulse Duration. After completing the initial setup of paragraph 4-41 and the Selected Energy test of paragraph 4-45, proceed as follows:

- a) Connect the oscilloscope (Table 4-1) to the BNC connector on back energy meter (Table 4-1). Set oscilloscope to 0.5V/div, 1 ms/div and positive trigger.
- b) Depress POWER ① switch to on. Verify that the green indicator illuminates.
- c) Adjust the ENERGY SELECT ② switch to desired level.
- d) Depress CHARGE ③ pushbutton and allow instrument to charge.
- e) Depress the Discharge pushbuttons and observe waveform on the oscilloscope.
- f) Verify that the display closely matches that of Figure 4-6. The curve should be smooth and continuous, and the entire pulse duration should not exceed 10 milliseconds (at 10% of peak value).

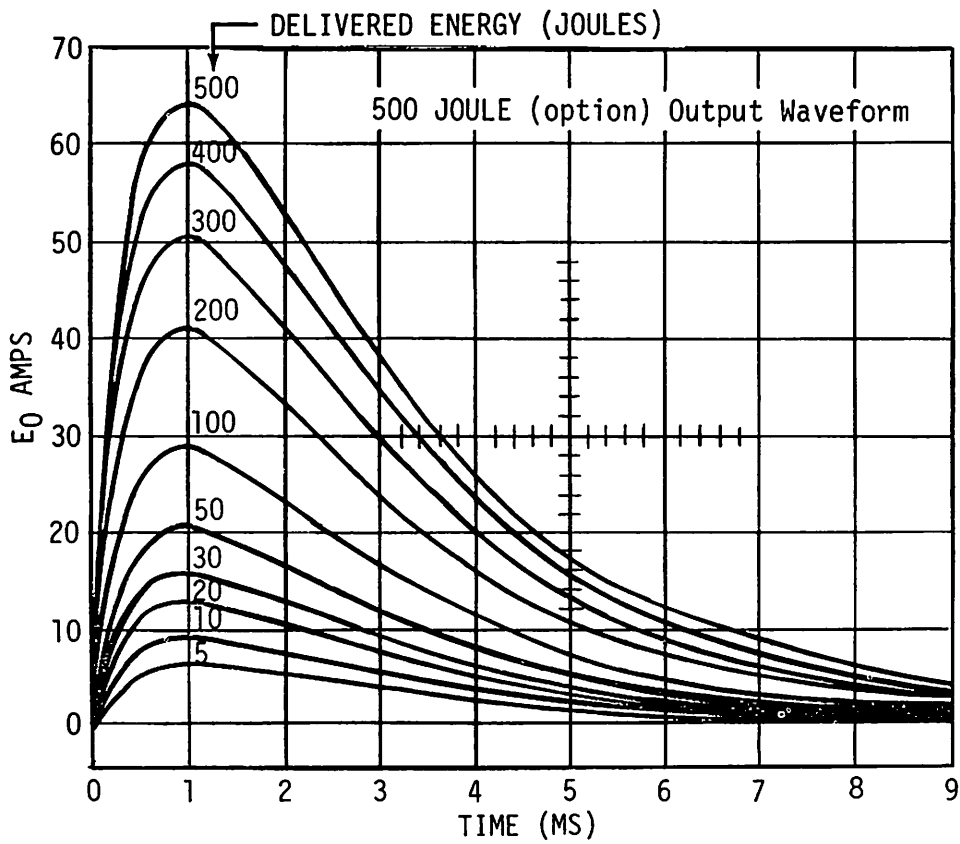
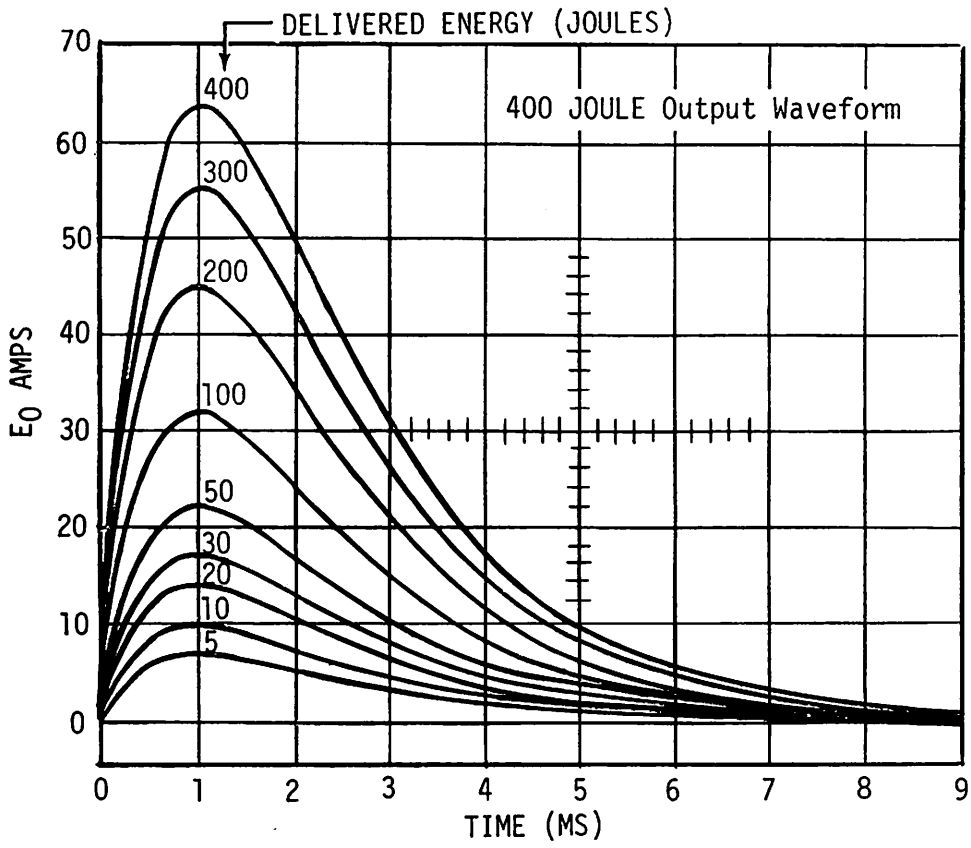

Figure 4-6. DC Defibrillator Output Waveforms

4-47. Output Waveform and Pulse Duration (Continued)

- g) Depress POWER ① switch off. Verify that the green indicator extinguishes.
- h) Disconnect and remove oscilloscope.

4-48. Internal Discharge (Dump). After completing the initial setup of paragraph 4-41, proceed as follows:

- a) Set the ENERGY SELECTOR ② to the maximum level.
- b) Depress POWER ① switch on. Verify that the green indicator illuminates.
- c) Depress CHARGE ③ switch and allow instrument to charge.
- d) When instrument is in ready state (charge indicator on steady), change the ENERGY SELECT ② position. Verify that the internal dump circuit functions.
- e) Recharge instrument to the maximum energy level. Remove paddles from energy meter. Hold paddles approximately one foot apart (open air) and depress both discharge pushbuttons.
- f) Verify that the charge indicator goes out indicating that the charge was discharged internally (dumped). Verify that there was no evidence of arcing or corona.
- g) Fasten paddles on energy meter. There should be no evidence of charge remaining on the contact plates.
- h) Depress POWER ① switch off. Verify green indicator is extinguished.

4-49. Test Load

- a) Place paddles in test load holders on instrument.
- b) Depress POWER ① switch on.
- c) Set ENERGY SELECT ② switch to 200J.
- d) Depress CHARGE ③ switch and when instrument is in ready state, discharge instrument.
- e) Verify that the test load LED flashes.
- f) Repeat (a) through (d) above except at 100J. Verify that the test load LED does not flash.
- g) Depress POWER ① switch off.

#### 4-50. Synchronizer Test

- a) Connect cardioscope/recorder module and defibrillator module together.
- b) Connect a 1 mv ECG signal to the patient cable input of the cardioscope/recorder module. (Refer to paragraph 4-15).
- c) Switch the cardioscope/recorder module on and adjust the ECG SIZE and QRS volume control to obtain an audible beep with each QRS complex.
- d) Switch defibrillator power on and observe that the synchronizer indicator is off.
- e) Depress the SYNC switch on and verify that sync indicator light blinks off momentarily with each R-wave on the cardioscope. Verify that the cardioscope trace contains an intensification blip.
- f) Cycle the defibrillator power off and on again. The sync indicator should remain off when power is reapplied and the intensification blip on the cardioscope (CRT) should not be present.
- g) With the defibrillator power on, set the ENERGY SELECT switch to 50 joules. Charge the defibrillator and discharge unit into the energy meter to insure proper operation.
- h) Depress the SYNC pushbutton switch on. Charge the defibrillator to 50 joules and depress the discharge buttons. Discharge should only occur during the R-wave detection as indicated by the sync light blinking.
- i) Verify that the SYNC indicator has turned off following discharge.
- j) With the instrument in the sync mode (SYNC indicator on), slide the cardioscope/recorder module and defibrillator module apart. Verify that the SYNC indicator turns off and there are no intensification blips on the cardioscope (CRT).
- k) Verify that the SYNC indicator cannot be turned on when the modules are separated.

#### 4-51. Major Component Removal and Installation (DC Defibrillator)

The following procedures provide the sequence for removing and installing the major components of the DC defibrillator.

Installation is for the most part the opposite of removal so only the removal procedures are provided. Special installation notes as required are provided as part of the removal or disassembly procedure. Remove or disassemble only to the point required. Figure 4-7 provides an exploded view of the DC defibrillator to assist in the following procedure.

Note: Prior to performing the following procedures, the POWER ① switch must be turned off and the paddles disconnected from the connector on the instrument.

4-52. Upper and Lower Case Separation. Refer to Figure 4-7 and proceed as follows:

Note: Installation procedures are essentially the reverse of the procedures presented below.

- 1) Remove sixteen screws ① securing upper case ② to lower case ③. Note different length of screws. Use caution when reinserting screws.

CAUTION

Before removing upper case, observe location of charge storage capacitor ⑫ coil and transfer relay ⑥. Keep hands clear of those areas.

- 2) Carefully lift top case ② straight up and to the left side of the lower case. The wiring harness and flex circuit will keep the two halves from being able to be pulled completely apart.
- 3) Using a 20K, 20 watt resistor on the end of a high voltage probe, insure that the charge storage capacitor is discharged.
- 4) The instrument is now in the test configuration. If further dis-assembly is required proceed to paragraph 4-53.

4-53. General Disassembly (see Figure 4-7). After completing the test and calibration procedures in paragraph 4-40 proceed as follows:

Note: Installation procedures are essentially the reverse of the procedures presented below.

- 1) To remove the main PCB ④, disconnect six connectors (P1 through P6) from the board. Remove seven screws ⑤ securing board to case. Lift up PCB ④ from case and remove from instrument.
- 2) To remove relay assembly ⑥ disconnect the slide-on wire clips (14 places) connected to terminals. Remove four screws ⑦ securing relay assembly to instrument and lift unit up and out of instrument.

CAUTION

When lifting relay assembly out of the instrument, be careful not to rub the relay contacts on the sides of the interior instrument wall casing.

- 3) To remove the charger PCB ⑧, lift paddle connector ⑪ up and to the side of instrument. Lift up and out bracket ⑩.

Remove connector P1 from PCB. Remove four screws ⑨ securing board to case. Lift the charger PCB ⑧ assembly up and out of instrument.

Note: This assembly includes the power cord and heat sink assembly.

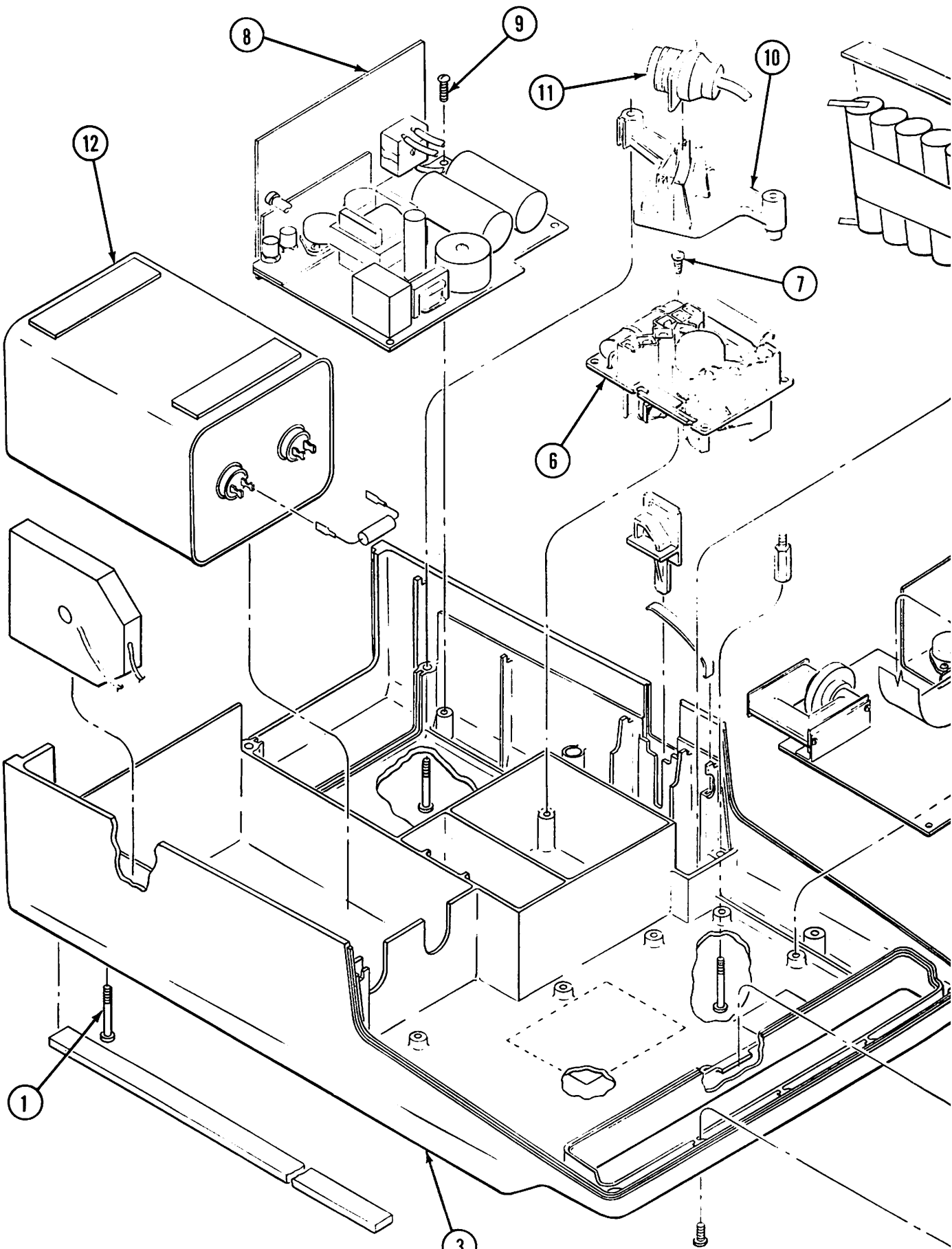

4-39

3



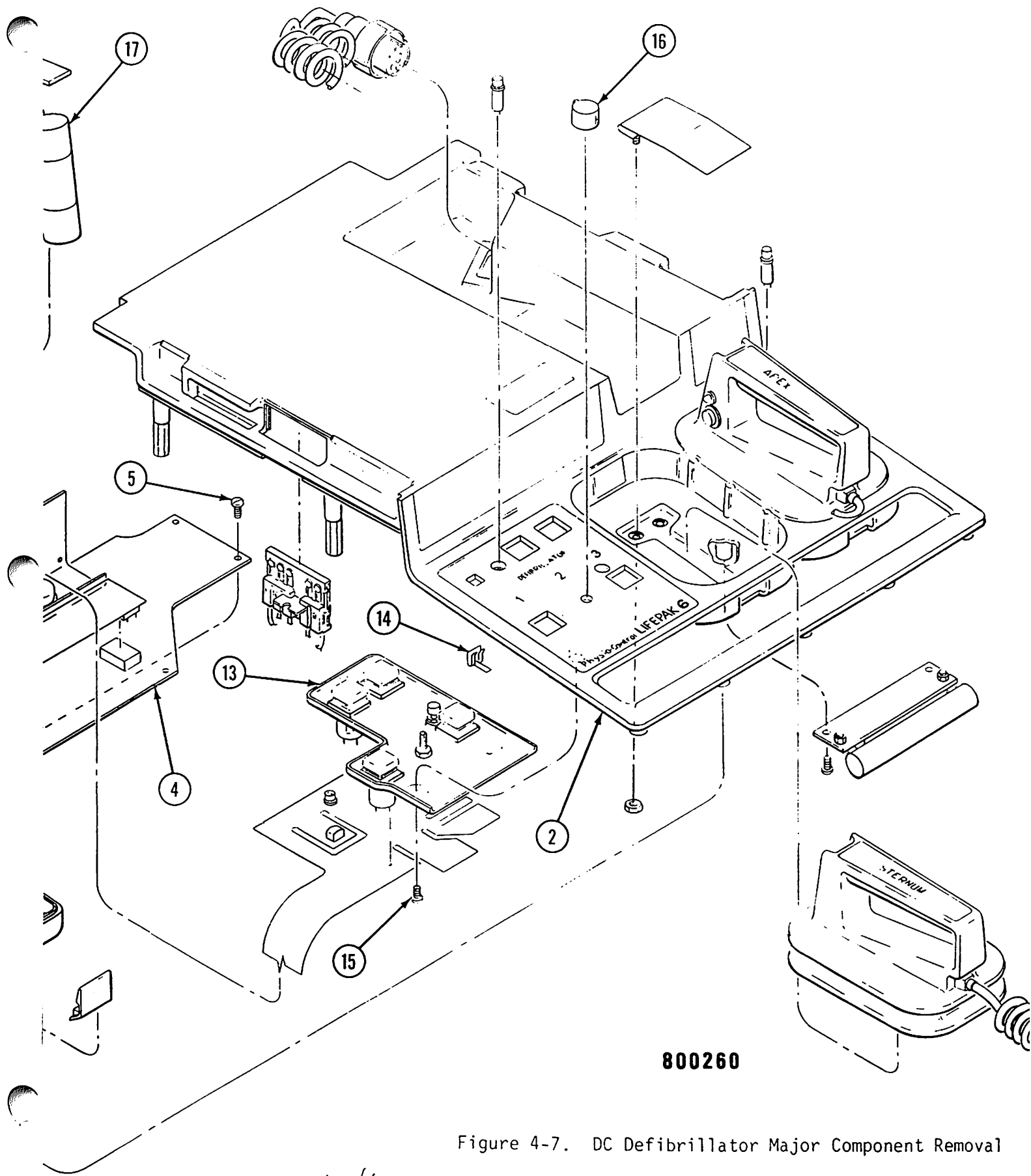

800260

Figure 4-7. DC Defibrillator Major Component Removal

4.40

## SECTION V ILLUSTRATED PARTS LIST

### 5-1 GENERAL

This section provides the illustrated parts breakdown lists and describes the parts for LIFEPAK 6 instrument. Table 5-1 lists the parts lists and assembly drawings for the Cardioscope/Recorder and Table 5-2 lists the parts lists and assembly drawings for the DC Defibrillator.

### 5-2 PARTS LISTS

- 1) Figure and Index Number. This column contains the figure and index number of the illustrated assembly and the assigned index number for each part.
- 2) Reference Designation (REF DES). This column contains alphanumeric listing of all electronic designations appearing on the schematic diagram.
- 3) Part Number. The Physio-Control Corporation (PCC) part number or standard part number is contained in this column for each part listed.
- 4) Description. This column contains the nomenclature and descriptive information for each part listed.
- 5) Units Per Assembly. This column lists the total quantity of parts for each particular assembly. The abbreviation "REF" (reference) indicates that the part has been listed for reference purposes.
- 6) Used On Code. This column contains an alphabetical code which indicates configuration differences. Consult the first entry in the parts list for code effectivity.

### 5-3 PART ORDERING

Some parts may be purchased locally. When ordering from Physio-Control Corporation, give the instrument model number and serial number. Include information listed in the parts list under headings: PCC Part No., REF. DES., Component Value, and DESCRIPTION. Different parts may be substituted by Physio-Control to reflect modifications and improvements of instrument circuitry.

TABLE 5-1

## CARDIOSCOPE/RECORDER PARTS LIST AND ASSEMBLY DRAWINGS

DRAWING NO.*	NOMENCLATURE	FIGURE NO.
800270	Cardioscope/Recorder Final Assembly	5-1
800151	Main Flex Cable Assembly	5-2
300170	Control Flex Cable Assembly	5-3
800033	Recorder PCB Assembly	5-4
800101	Preamplifier PCB Assembly	5-5
800157	Monitor Charger PCB Assembly	5-6
800159	No-Fade PCB Assembly	5-7
300161	Display PCB Assembly	5-8
800112	Power Supply PCB Assembly	5-9
800053	Rate PCB Assembly	5-10
800782	Interconnect Assembly	5-11

TABLE 5-2

## DC DEFIBRILLATOR PARTS LIST AND ASSEMBLY DRAWINGS

DRAWING NO.*	NOMENCLATURE	FIGURE NO.
800260	DC Defibrillator Final Assembly	5-12
800348	Panel Assembly	5-13
800165	Control Flex Cable Assembly	5-14
800192	Main Wire Harness Assembly	5-15
800041	Charger PCB Assembly	5-16
800163	Main PCB Assembly	5-17
800167	Test Load PCB Assembly	5-18
800193-(00)	Interconnect Assembly	5-19

\*Check change information section at the rear of this manual.

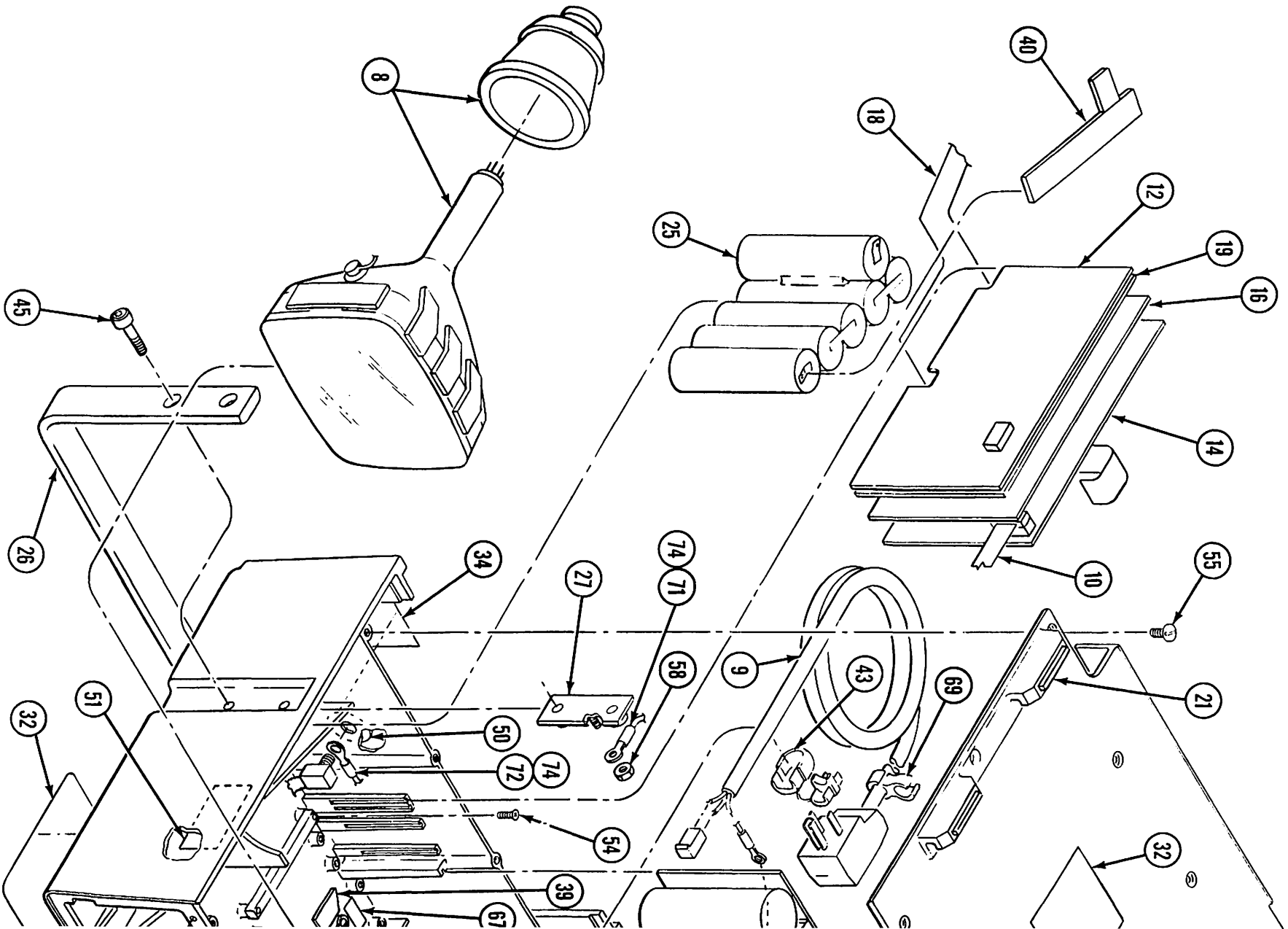

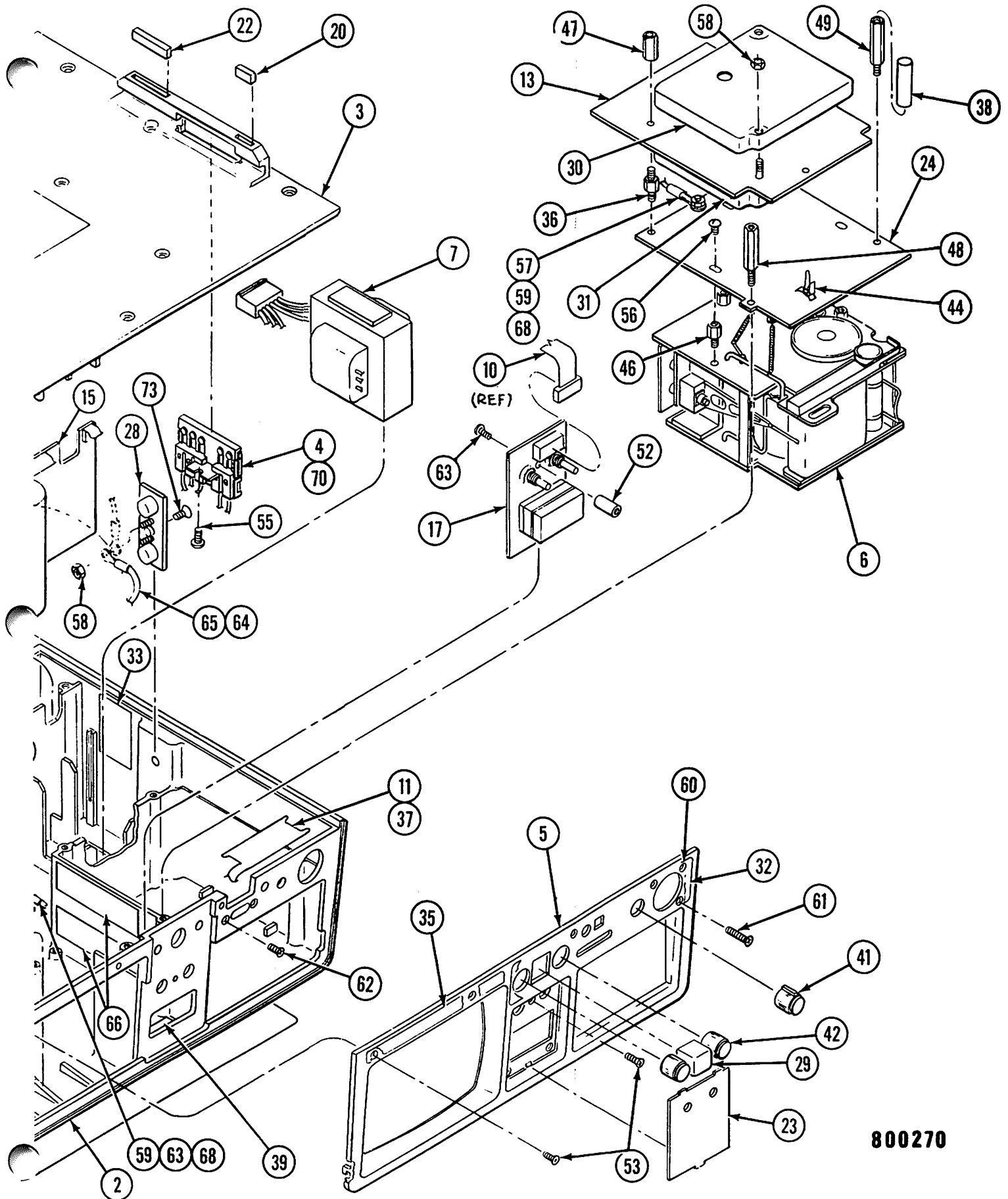

800270

Figure 5-1 Cardioscope/Recorder Final Assembly

5-3/5-4

5-4

Jan 19

## PARTS LIST

FIG AND ITEM No.	REF. DES.	PCC PART No.	DESCRIPTION	UNITS PER ASSY	USED ON CODE
5-1					
1		800270-00	MONITOR FINAL ASSY LP/6	REF	
2		800308-01	CASE ASSY - PAINTED	1	
3		800310-03	COVER ASSY - PAINTED	1	
4		800782-00	INTERCONNECT ASSY - MONITOR	1	
5		800313-00	BEZEL	1	
6		800273-00	RECORDER ASSY	1	
7		800357-00	TRANSFORMER ASSY	1	
8		800632-00	CRT ASSEMBLY	1	
9		800356-02	POWER CORD ASSY	1	
10		800014-02	CABLE ASSY, FLAT	1	
11		800170-00	PCF ASSY, CONTROL	1	
12		800112-00	PCB ASSY - POWER SUPPLY & DEFL	1	
13		800101-00	PCB ASSY - PREAMP	1	
14		800053-00	PCB ASSY - RATE	1	
15		800157-00	PCB ASSY - MON. CHARGER	1	
16		800159-00	PCB ASSY - NO FADE	1	
17		800161-00	PCB ASSY - DISPLAY	1	
18		800151-00	PCF ASSY - MAIN	1	
19		800343-01	SHIELD - POWER SUPPLY	1	
20		800316-00	FOOT, MOUNTING	1	
21		800316-01	FOOT, MOUNTING	1	
22		800316-02	FOOT, MOUNTING	2	
23		800315-04	PANEL - FRONT	1	
24		800272-02	PLATE - RECORDER MTG.	1	
25		800285-00	BATTERY	1	
26		800317-00	HANDLE - MONITOR	1	
27		800318-02	PLATE, ATTACHMENT	1	
28		800318-01	PLATE, ATTACHMENT	1	
29		800372-01	BUTTON, SWITCH - ENGRAVED	1	
30		800402-03	COVER - TOP, PREAMP	1	
31		800403-02	COVER - BOTTOM, PREAMP	1	

## PARTS LIST

FIG AND ITEM No.	REF. DES.	PCC PART No.	DESCRIPTION	UNITS PER ASSY	USED ON CODE
5-1					
32		800512	LABEL MATRIX	1	
33		800278-00	LABEL, FUSE	1	
34		800504-02	LABEL, ECG OUTPUT	1	
35		800389-01	LABEL, LOGO, LP6	1	
36		800446-01	SPACER MALE/MALE 5/16 HEX 6-32x.375	2	
37		800597-00	PAD, RETAINER	1	
38		200319-00	TUBING, TFE, 1 x 1.25	1	
39		200318-15	TAPE, NEO SPONGE 1/2 x 1/8	A/R	
40		200318-13	TAPE, NEO SPONGE 3/4 x 1/16	A/R	
41		200126-00	KNOB - INSTRUMENTATION	3	
42		200304-00	KNOB - RING BASE	1	
43		200150-00	STRAIN RELIEF - RIGHT ANGLE	1	
44		200187-01	RETAINER, LOCKING, .375	1	
45		200190-01	SCREW 1/4-20 x 1/2 SOC HD CAP	4	
46		200192-02	STANDOFF MALE/FEM 6-32 x .25	3	
47		200191-48	STANDOFF FEM/FEM 6-32 x .812	2	
48		200192-34	STANDOFF MALE/FEM 6-32 x 1.25	1	
49		200302-34	STANDOFF MALE/FEM 6-32 x 1.25 x 1/4	1	
50		02-35159-00	COVER, PHONE JACK	1	
51		01-50013-00	LABEL, HIGH VOLTAGE	1	
52		90-02074	STANDOFF 4-40 x 9/16 x 1/4	1	
53		90-01243	SCREW 4-40 x 3/8 FH, P, BLK	4	
54		90-01021	SCREW 4-40 x 3/8 BH, S, CP	8	
55		90-01051	SCREW 6-32 x 1/4 BH, S, BLK	12	
56		90-01202	SCREW 6-32 x 3/16 BH, S, CP	3	
57		90-03019	KEPNUT 4-40 x 1/4	1	
58		90-03021	KEPNUT 6-32 x 1/4	5	
59		90-04005	WASHER, #4, LOCK, I.T.	2	
60		90-01237	SCREW 4-40 x 3/4 FH, P, BLK	2	
61		90-01238	SCREW 4-40 x 11/16 FH, P, BLK	1	
62		90-01199	SCREW 4-40 x 1/4 FH, P, BLK	4	

## PARTS LIST

FIG AND ITEM No.	REF. DES.	PCC PART No.	DESCRIPTION	UNITS PER ASSY	USED ON CODE
5-1					
63		90-01012	SCREW 4-40 x 1/4 BH, S, CP	2	
64		90-06068	LUG, #6 RING	1	
65		90-11053	WIRE, 22 AWG GRN	A/R	
66		90-08017	TAPE, DBL BACK, VINYL 1/2	A/R	
67		90-08030	TAPE, MYLAR	A/R	
68		90-06072	LUG, #4 RING	2	
69		800775-00	CLIP - CORD	1	
70		90-08027	TAPE - WEATHERSTRIP 5/16 x 3/4	A/R	
71		90-06069	LUG, RING, #6	1	
72		90-06044	LUG - 3/8 RING, 16-22 AWG	1	
73		90-01062	SCREW, FH, P, BLK OX, 6-32 x 3/8	1	
74		200357-57	WIRE, STRANDED, 18 AWG GRN	A/R	
75		800562-00	STYLUS REPLACEMENT KIT (NOT SHOWN)	1	



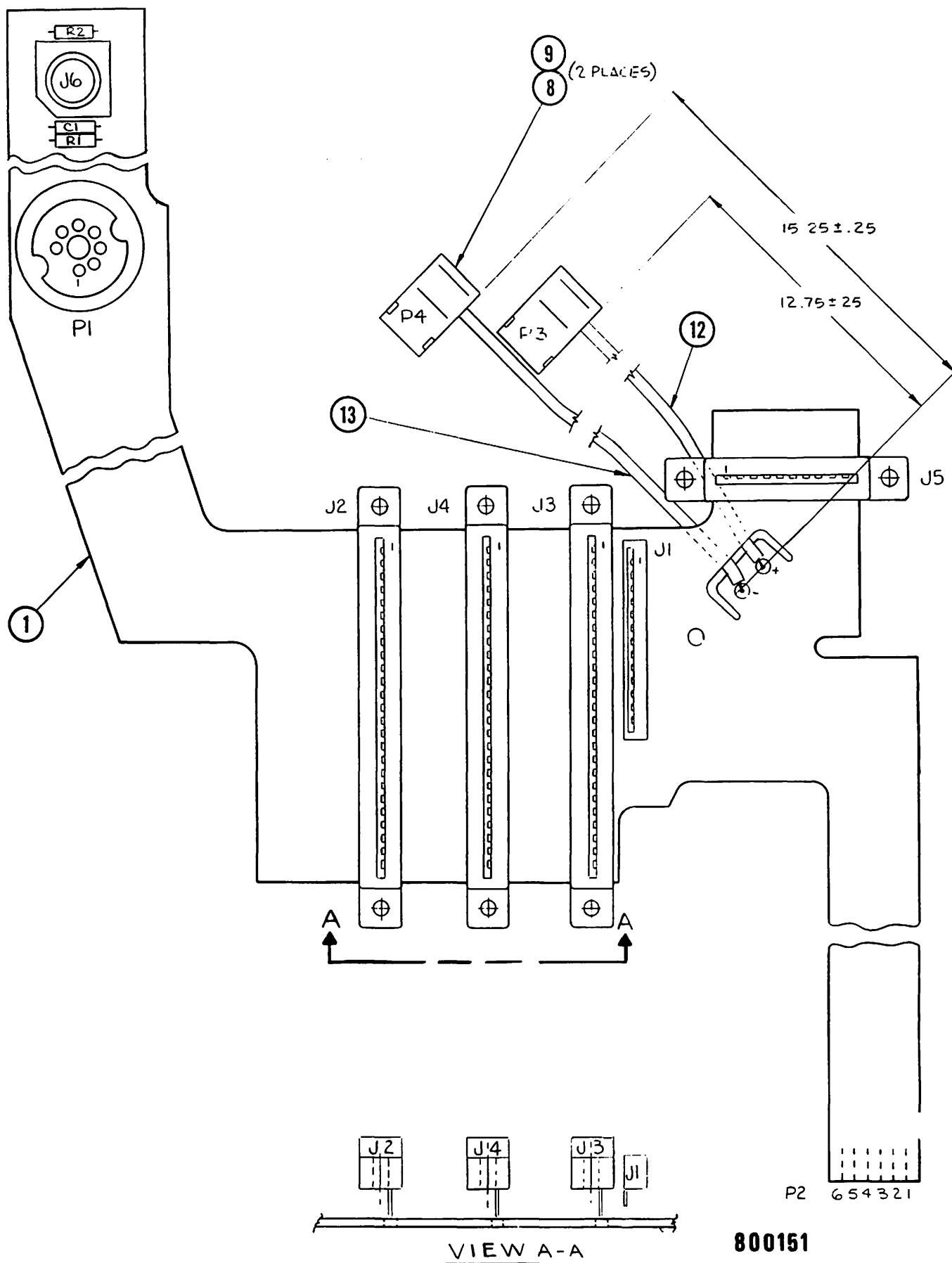

800151

Figure 5-2 Main Flex Cable Assembly  
5-8

Jan 1979

## PARTS LIST

FIG AND ITEM No.	REF. DES.	PCC PART No.	DESCRIPTION	UNITS PER ASSY	USED ON CODE
5-2					
1		800151-00	MAIN FLEX CIRCUIT ASSY MON.	REF	
2	C1	200049-39	CAPACITOR, .1 $\mu$ f, 50V	1	
3	J1	200073-07	CONNECTOR, TOP ENTRY, 13 CONTACT	1	
4	J2,3,4	200101-04	CONNECTOR - EDGE, 25 CONTACT	3	
5	J5	200101-00	CONNECTOR - EDGE, 10 CONTACT	1	
6	J6	200136-00	PHONE JACK	1	
7	P1	800373-00	CONNECTOR, CRT	1	
8	P3,4	02-35527-00	CONTACT - LUG, .250 FLAG	2	
9		02-35528-00	HOUSING - RECEPT., .250 FLAG	2	
10	R1	200055-193	RESISTOR, MF, 1K, 1%, 1/8W	1	
11	R2	200055-480	RESISTOR, MF, 1M, 1%, 1/8W	1	
12		200358-56	WIRE, 18 AWG, RED	A/R	
13		200358-55	WIRE, 18 AWG, BLACK	A/R	

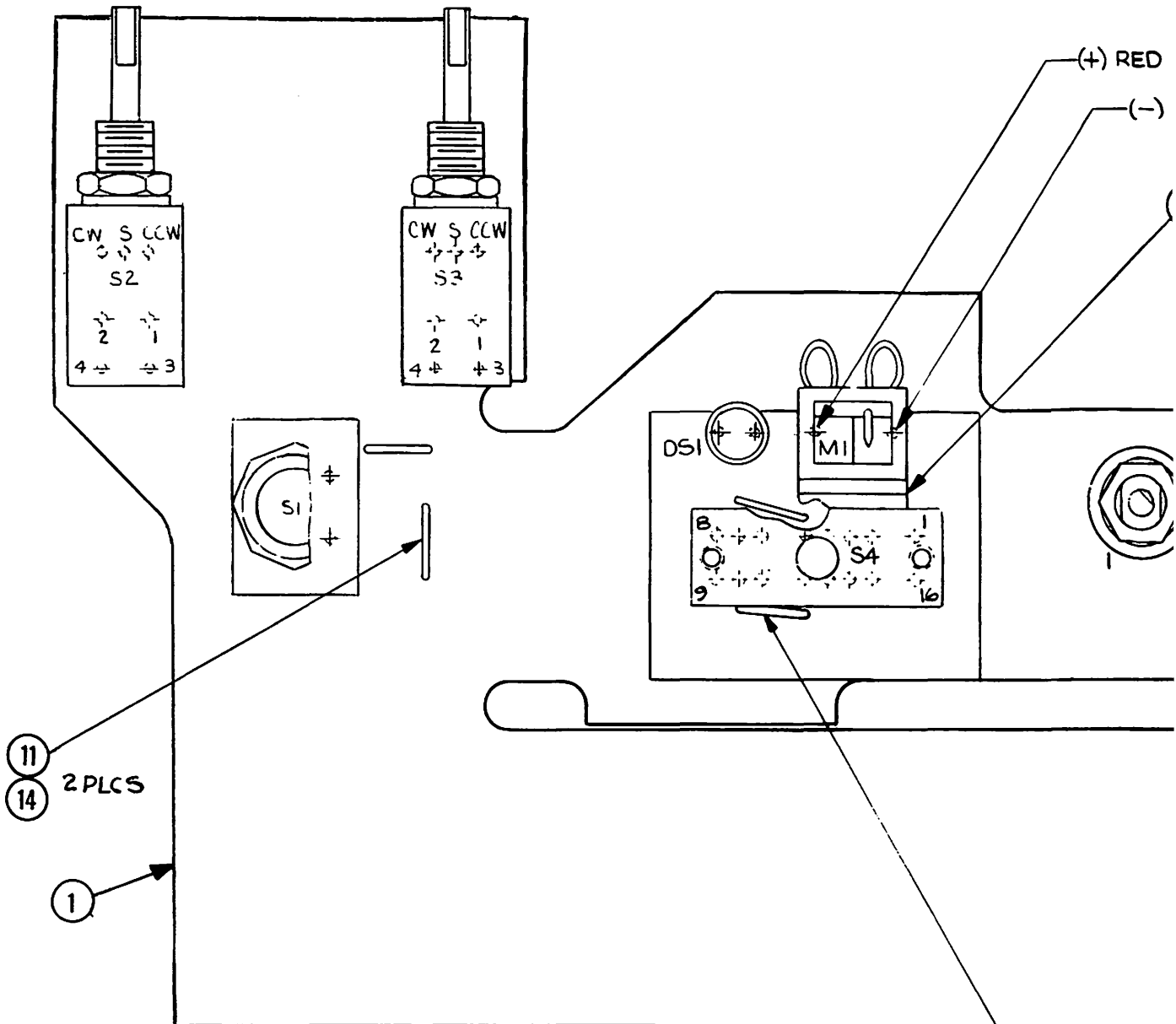

11  
14 2 PLCS

1

12 5 PLACES

1 (REF)

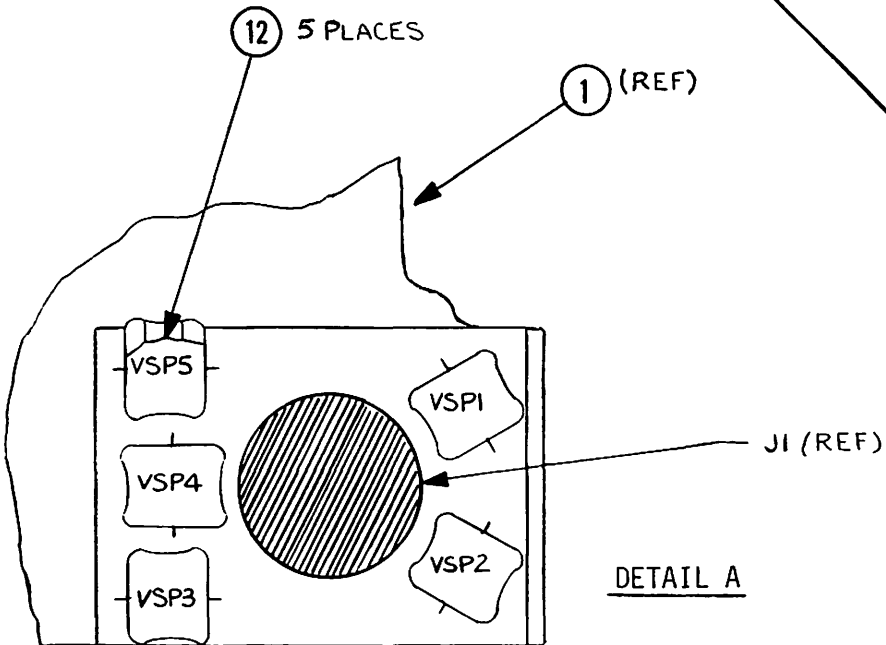

DETAIL A

5-10

WIRE

LACK WIRE

10) AIR

155

18 P1 1

SEE DETAIL A

6

P2

13

P3

11) 2 PLCS  
14)

800170

Figure 5-3 Control Flex Assembly

5-10/5-11

Jan

## PARTS LIST

FIG AND ITEM No.	REF. DES.	PCC PART No.	DESCRIPTION	UNITS PER ASSY	USED ON CODE
5-3					
1		800170-00	CONTROL FLEX ASSY MON. LP/6	REF	
2	J1	800473-00	CONNECTOR, 6 CONTACT	1	
3	DS1	200131-00	L.E.D., P.C. MOUNT	1	
4	M1	200129-01	METER, INDICATOR	1	
5	S2,3	800264-01	POT/SWITCH 5K OHM	2	
6	VSP1- VSP5	02-16011-00	SURGE PROTECTOR; 90V	5	
7	S1	800526-00	SWITCH, PUSHBUTTON	1	
8	S4	200155-00	SWITCH-BATON, 4P3T	1	
9	S5	200151-09	SWITCH, ROTARY 10 POS	1	
10		90-08006	TAPE 1/2 x 1/16 DBL. BACK	A/R	
11		90-07028	TEFLON TUBING #22	A/R	
12		90-07012	TUBING, SHRINK 3/8	A/R	
13		90-09136	WIRE, BUSS 18 AWG	A/R	
14		90-09138	WIRE, BUSS 22 AWG	A/R	

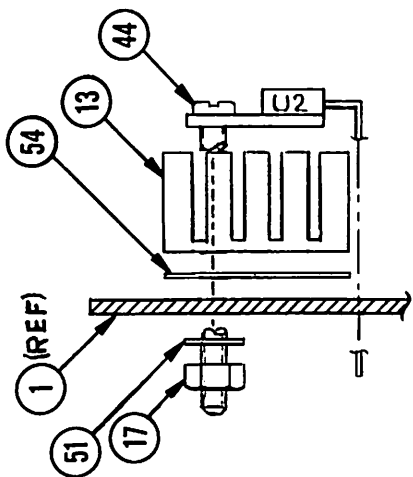
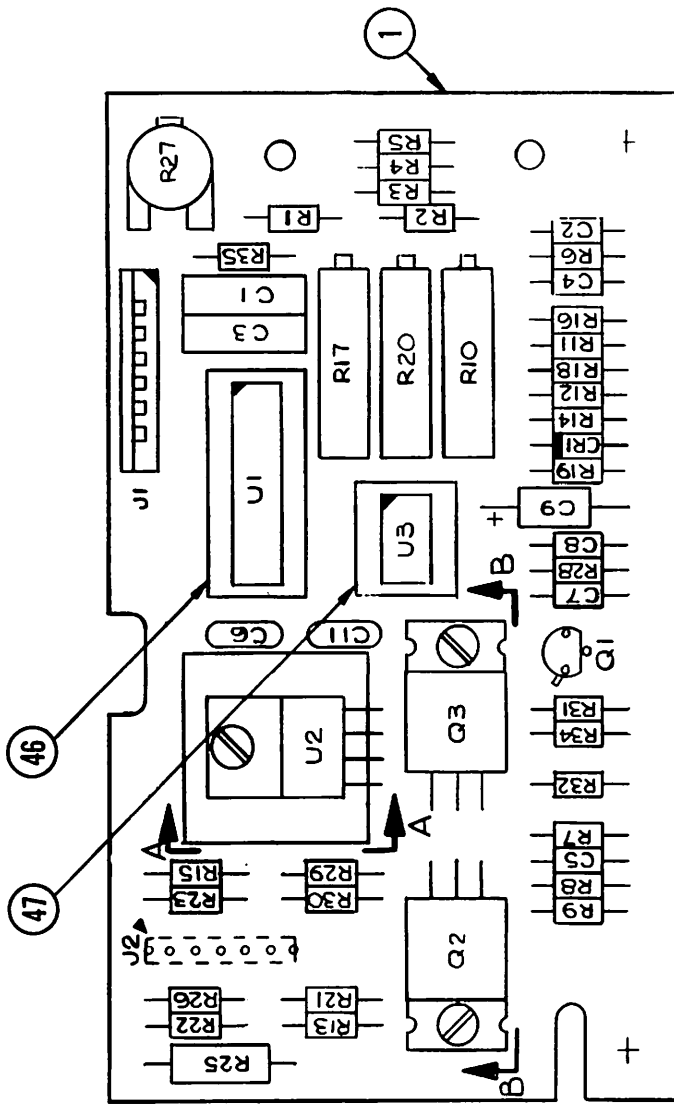

SECTION A-A

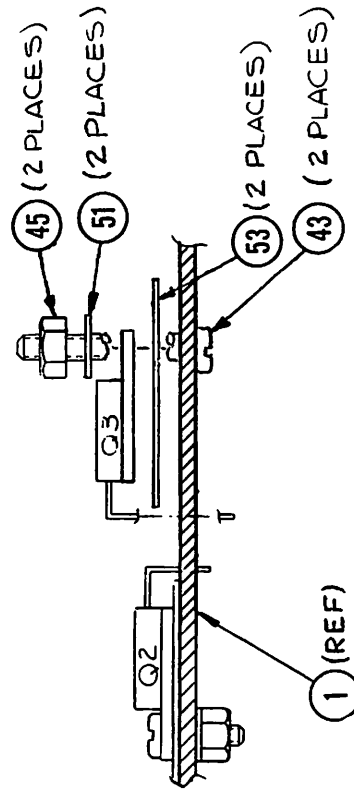

800033

SECTION B-B

Figure 5-4 Recorder PCB Assembly

## PARTS LIST

FIG AND ITEM No.	REF. DES.	PCC PART No.	DESCRIPTION	UNITS PER ASSY	USED ON CODE
5-4					
1		800033-00	RECORDER PCB ASSY MON. LP/6	REF	
2	C1,C3	200214-16	CAPACITOR, POLYFILM, .022uf/50V,5%	2	
3	C2,C7	200049-20	CAPACITOR, AXIAL, CER, .0027 ufd/50V	2	
4	C4,C5	200049-15	CAPACITOR, AXIAL CER, .001ufd/50V	2	
5	C6	200264-24	CAPACITOR, RADIAL CER, 1ufd/50V	1	
6	C8	200049-27	CAPACITOR, AXIAL CER, .01ufd/50V	1	
7	C9	02-12606-00	CAPACITOR, AXIAL TANT, 2.2ufd/20V	1	
8			DELETED		
9	C11	200264-26	CAPACITOR, RADIAL CER, 2.2ufd/50V	1	
10	J1	200073-00	CONN, 6 CONTACT, FLEX, LOCK TOP ENTRY	1	
11	J2	200113-04	CONN, 7 PIN, .10 O.C.	1	
12	CR1	02-14172-00	DIODE 1N821A	1	
13		200153-00	HEATSINK	1	
14	U2	200056-00	I.C. POWER OP-AMP, uA 759 U1C	1	
15	U1	200199-00	I.C. TL084	1	
16	U3	02-14359-00	I.C. NE555	1	
17		90-03005	NUT #4-40 x 1/4 CP	2	
18	R27	200285-00	POT, 50K, 3/4 TURN	1	
19	R10	02-11513-00	POT, 100 OHM, 20 TURN	1	
20	R17	02-11518-00	POT, 5K, 20 TURN	1	
21	R20	02-11519-00	POT, 10K, 20 TURN	1	
22	R1	200055-376	RESISTOR, RN55D, 82.5K, 1%, 1/8W	1	
23	R2	200055-272	RESISTOR, RN55D, 6.81K, 1%, 1/8W	1	
24	R3	200055-360	RESISTOR, RN55D, 56.2K, 1%, 1/8W	1	
25	R4	200055-284	RESISTOR, RN55D, 9.09K, 1%, 1/8W	1	
26	R5,6,23	200055-388	RESISTOR, RN55D, 110K, 1%, 1/8W	3	
27	①	200055-384	RESISTOR, RN55D, 100K, 1%, 1/8W	6	
28	R9	02-06013-00	RESISTOR, CF, 5.1 OHM, 5%, 1/4W	1	
29	R11	02-06062-00	RESISTOR, CF, 560 OHM, 5%, 1/4W	1	
30	R13,22	200055-355	RESISTOR, RN55D, 49.9K, 1%, 1/8W	2	

## PARTS LIST

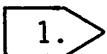
FIG AND ITEM No.	REF. DES.	PCC PART No.	DESCRIPTION	UNITS PER ASSY	USED ON CODE
5-4					
31	R18	200055-336	RESISTOR, RN55D, 31.6K, 1%, 1/8W	1	
32	R19	02-06066-00	RESISTOR, CF, 820 OHM, 5%, 1/4W	1	
33	R21	02-06044-00	RESISTOR, CF, 100 OHM, 5%, 1/4W	1	
34	R26	02-06051-00	RESISTOR, CF, 200 OHM, 5%, 1/4W	1	
35	R25	02-09167-00	RESISTOR, CC, 1 OHM, 5%, 1/2W	1	
36	R28	02-06096-00	RESISTOR, CF, 15K, 5%, 1/4W	1	
37	R29	02-06037-00	RESISTOR, CF, 51 OHM, 5%, 1/4W	1	
38	R30	02-06054-00	RESISTOR, CF, 270 OHM, 5%, 1/4W	1	
39	R31	02-06109-00	RESISTOR, CF, 51K, 5%, 1/4W	1	
40	R32	02-06116-00	RESISTOR, CF, 100K, 5%, 1/4W	1	
41	R34	02-06140-00	RESISTOR, CF, 1M, 5%, 1/4W	1	
42	R35	02-06068-00	RESISTOR, CF, 1K, 5%, 1/4W	1	
43		90-01012	SCREW 4-40 x 1/4 BH, S, CP	2	
44		90-01040	SCREW 4-40 x 5/16 PH, S, CP	1	
45		90-03001	NUT, 4-40 x 3/16, CP	1	
46		200033-01	SOCKET, I.C., 14 PIN	1	
47		200033-02	SOCKET, I.C., 8 PIN	1	
48	Q1	02-14611-00	TRANSISTOR, PN2484	1	
49	Q2	02-14625-00	TRANSISTOR, T1P32A	1	
50	Q3	02-14585-00	TRANSISTOR, T1P110	1	
51		90-04005	WASHER, #4 LOCK, I.T.	3	
52		800814-01	THERMAL - COND. INSULATOR	2	
53		800814-02	THERMAL - COND. INSULATOR	1	
		 1.	R7, R8, R12, R14, R15, R16		



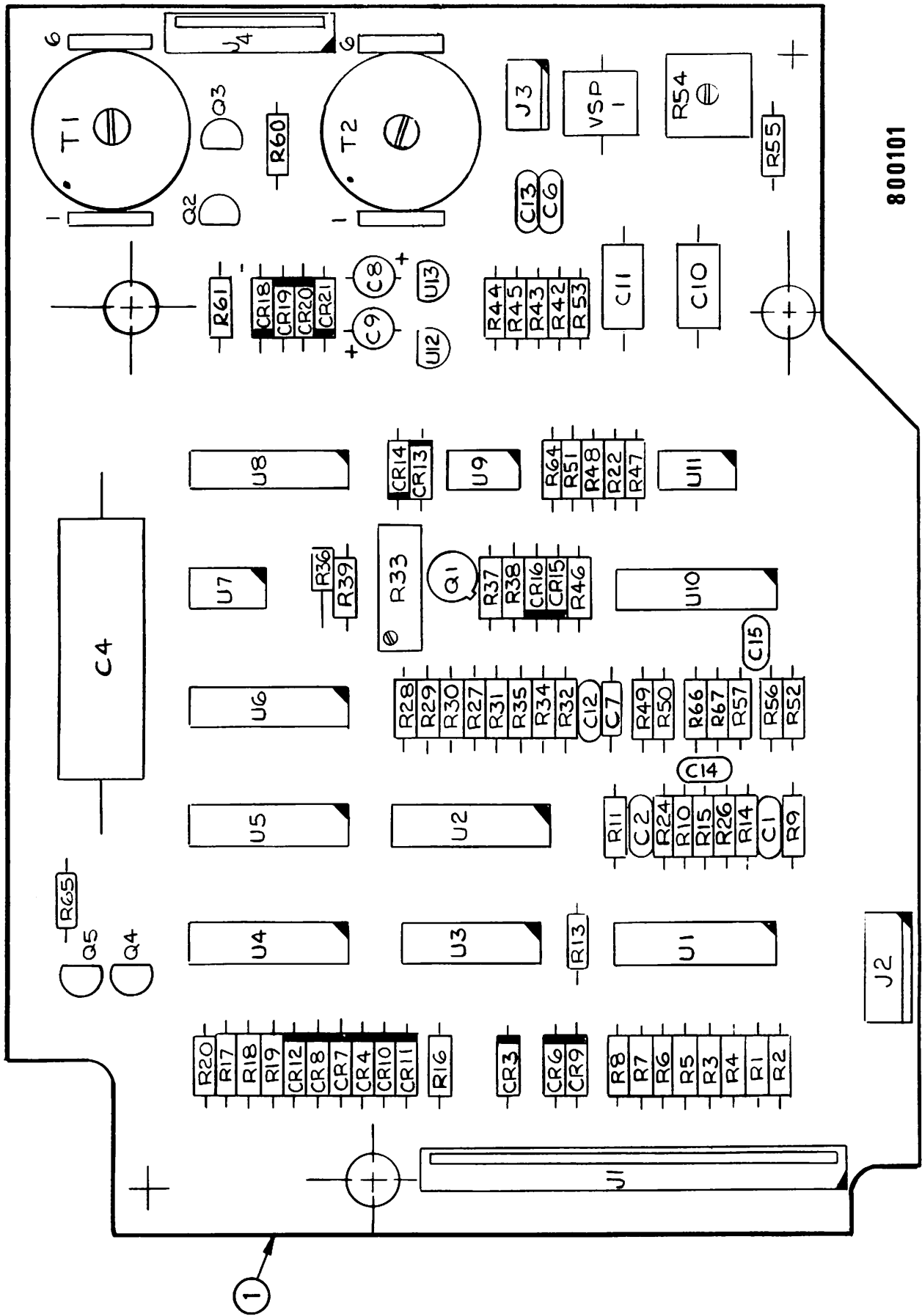

800101

Figure 5-5 Preamplifier PCB Assembly

## PARTS LIST

FIG AND ITEM No.	REF. DES.	PCC PART No.	DESCRIPTION	UNITS PER ASSY	USED ON CODE
5-5					
1		800101-00	PREAMP PCB ASSY MON LP/6	REF	
2	C1	200264-24	CAPACITOR, 1.0 $\mu$ f/50V, MONO	1	
3	C2,12	02-12011-00	CAPACITOR, 100pF/1KV, DISC	2	
4	C4	200286-45	CAPACITOR, 10 $\mu$ f/50V	1	
5	C6,13	200264-26	CAPACITOR, 2.2/50V, CER. RADIAL	2	
6	C7	200049-39	CAPACITOR, .1 $\mu$ f/50V	1	
7	C8,9	02-12741-00	CAPACITOR, 4.7 $\mu$ f/20V, TANT	2	
8	C10	200211-81	CAPACITOR, .01 $\mu$ f/200V, MET. POLYCARB	1	
9	C11	200211-05	CAPACITOR, .1 $\mu$ f/50V, MET. POLYCARB	1	
10	J1	200073-12	CONNECTOR, 18 PIN	1	
11	J2	200096-01	CONNECTOR, 3 PIN	1	
12	J3	02-20323-00	CONNECTOR, 2 PIN	1	
13	J4	200073-00	CONNECTOR, 6 PIN	1	
14	CR3,4 6-16 18-21	02-14018-00	DIODE 1N914B	17	
15	U1,2,10	200287-00	I.C., TL064	3	
16	U4,5	200044-00	I.C., CD4051B	2	
17	U6,8	800741-00	I.C., CD4053B	2	
18	U7,9,11	200254-00	I.C., LF355N	3	
19			DELETED		
20	U12	200210-02	I.C., LM340LAZ-8	1	
21	U13	200209-19	I.C., LM320LAZ-8	1	
22	U3	02-11196-00	RESISTOR NETWORK, 14 PIN	1	
23	R1,3, 5,7	200055-575	RESISTOR, MF, 10M, 1%, 1/8W	4	
24	2.	200054-355	RESISTOR, MF, 49.9K, 1%, 1/8W	8	
25	R9	02-06144-00	RESISTOR, CF, 1.5M, 5%, 1/4W	1	
26	R10	02-06128-00	RESISTOR, CF, 330K, 5%, 1/4W	1	
27	R11	02-06133-00	RESISTOR, CF, 510K, 5%, 1/4W	1	

## PARTS LIST

FIG AND ITEM No.	REF. DES.	PCC PART No.	DESCRIPTION	UNITS PER ASSY	USED ON CODE
5-5					
28	R13,14, 15	02-06102-00	RESISTOR, CF, 27K, 5%, 1/4W	3	
29	3.	02-06092-00	RESISTOR, CF, 10K, 5%, 1/4W	6	
30	R22	02-08168-00	RESISTOR, CC, 10M, 5%, 1/4W	1	
31	R27,31	200054-317	RESISTOR, MF, 20K, 1%, 1/8W	2	
32	4.	200054-288	RESISTOR, MF, 10K, 1%, 1/8W	8	
33	R33	02-11582-00	RESISTOR, POT, 2K, 20TURN	1	
34	R34	200054-292	RESISTOR, MF, 11K, 1%, 1/8W	1	
35	R35,60	200055-480	RESISTOR, MF, 1M, 1%, 1/8W	2	
36	R36	200323-00	RESISTOR, CC, 30M, 1%, 3/4W	1	
37	R37	02-06080-00	RESISTOR, CF, 3.3K, 5%, 1/4W	1	
38	R38	02-08176-00	RESISTOR, CC, 22M, 5%, 1/4W	1	
39	R39	200055-522	RESISTOR, MF, 2.8M, 1%, 1/8W	1	
40	R43,45	200054-272	RESISTOR, MF, 6.81K, 1%, 1/8W	2	
41	R51,52	200054-329	RESISTOR, MF, 26.7K, 1%, 1/8W	2	
42	R53	200054-425	RESISTOR, MF, 267K, 1%, 1/8W	1	
43	R54	02-11553-00	RESISTOR, POT, 50K, 3/4TURN	1	
44	R55	200054-423	RESISTOR, MF, 255K, 1%, 1/8W	1	
45			DELETED		
46	R46	02-06140-00	RESISTOR, CF, 1M, 5%, 1/4W	1	
47	R64	02-06132-00	RESISTOR, CF, 470K, 5%, 1/4W	1	
48	T1,2	02-18284-00	TRANSFORMER, PREAMP	2	
49	Q1	200282-04	TRANSISTOR, 2N4393	1	
50	Q2,3	02-14626-00	TRANSISTOR, P1087E	2	
51	Q4,5	02-14574-00	TRANSISTOR, PNP2N3905	2	
52	VSP1	02-16009-00	VOLTAGE SURGE PROTECTOR 470V	1	
53	R61	02-06132-00	RESISTOR, CF, 470K, 5%, 1/4W	1	
54	C14	02-12101-00	CAPACITOR, CER, .0047ufd/50V	1	
55	C15	200049-38	CAPACITOR, CER, .082ufd/50V	1	

PARTS LIST

FIG AND ITEM No.	REF. DES.	PCC PART No.	DESCRIPTION	UNITS PER ASSY	USED ON CODE
5-5					
56	R24,26	200055-417	RESISTOR, MF, 280K, 1%, 1/8W	2	
57	R66,67	02-06147-00	RESISTOR, CF, 2M, 5%, 1/4W	2	
		<div style="display: flex; flex-direction: column; gap: 5px;"> <div style="border: 1px solid black; padding: 2px; display: inline-block;">1.</div> <div style="border: 1px solid black; padding: 2px; display: inline-block;">2.</div> <div style="border: 1px solid black; padding: 2px; display: inline-block;">3.</div> <div style="border: 1px solid black; padding: 2px; display: inline-block;">4.</div> </div>	<p>DELETED</p> <p>R2, R4, R6, R8, R28, R30, R47, R57</p> <p>R16, R17, R18, R19, R20, R65</p> <p>R29, R32, R42, R44, R48, R49, R50, R56</p>		

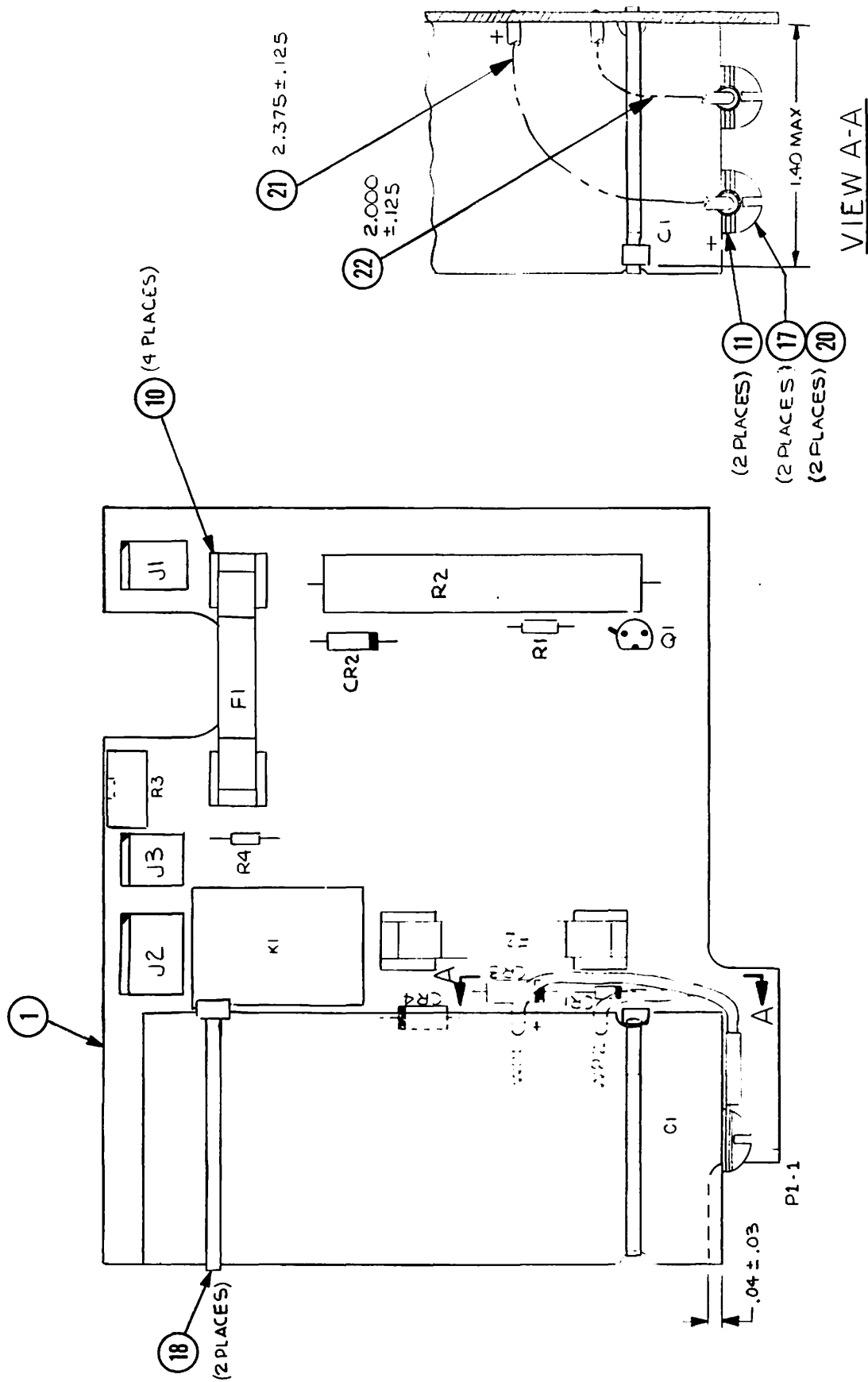

800157

Figure 5-6 Monitor Charger PCB Assembly

## PARTS LIST

FIG AND ITEM No.	REF. DES.	PCC PART No.	DESCRIPTION	UNITS PER ASSY	USED ON CODE
5-6					
1		800157-00	PCB ASSY, CHARGER MON.	REF	
2	C1	200100-01	CAPACITOR, 9000uf/25V	1	
3	J1, J3	200096-00	CONNECTOR, 2 PIN, LOCKING	2	
4	J2	200096-01	CONNECTOR, 3 PIN, LOCKING	1	
5	CR1	200284-05	DIODE 1N4005	1	
6	CR2	200086-21	DIODE 1N4106	1	
7	CR3,4	02-14016-00	DIODE 1R30S6	2	
8	F1	200256-145	FUSE 250V/2 AMP SLO-BLO	1	
9	F2	200256-130	FUSE 250V/.25 AMP SLO-BLO	1	
10		02-35464-00	FUSE HOLDER, PCB	4	
11		90-06043	LUG, RING #10	2	
12	R3	02-11533-00	POT, 5K 3/4 TURN	1	
13	K1	02-18569-01	RELAY SPDT, 3A	1	
14	R1	02-06060-00	RESISTOR, CF, 470 OHM, 5%, 1/4W	1	
15	R2	02-09617-00	RESISTOR, WW, 50 OHM, 5%, 10W	1	
16	R4	02-06076-00	RESISTOR, CF, 2.2K, 5%, 1/4W	1	
17		90-01123	SCREW, 10-32 x 1/4, BH, CP, S	2	
18		90-10012	TIE WRAP, LGE	2	
19	Q1	02-14606-00	TRANSISTOR PN2907A	1	
20		90-04018	WASHER, #10 I.T. LOCK	2	
21		90-11042	WIRE, #18 RED	A/R	
22		90-11046	WIRE, #18 BLACK	A/R	

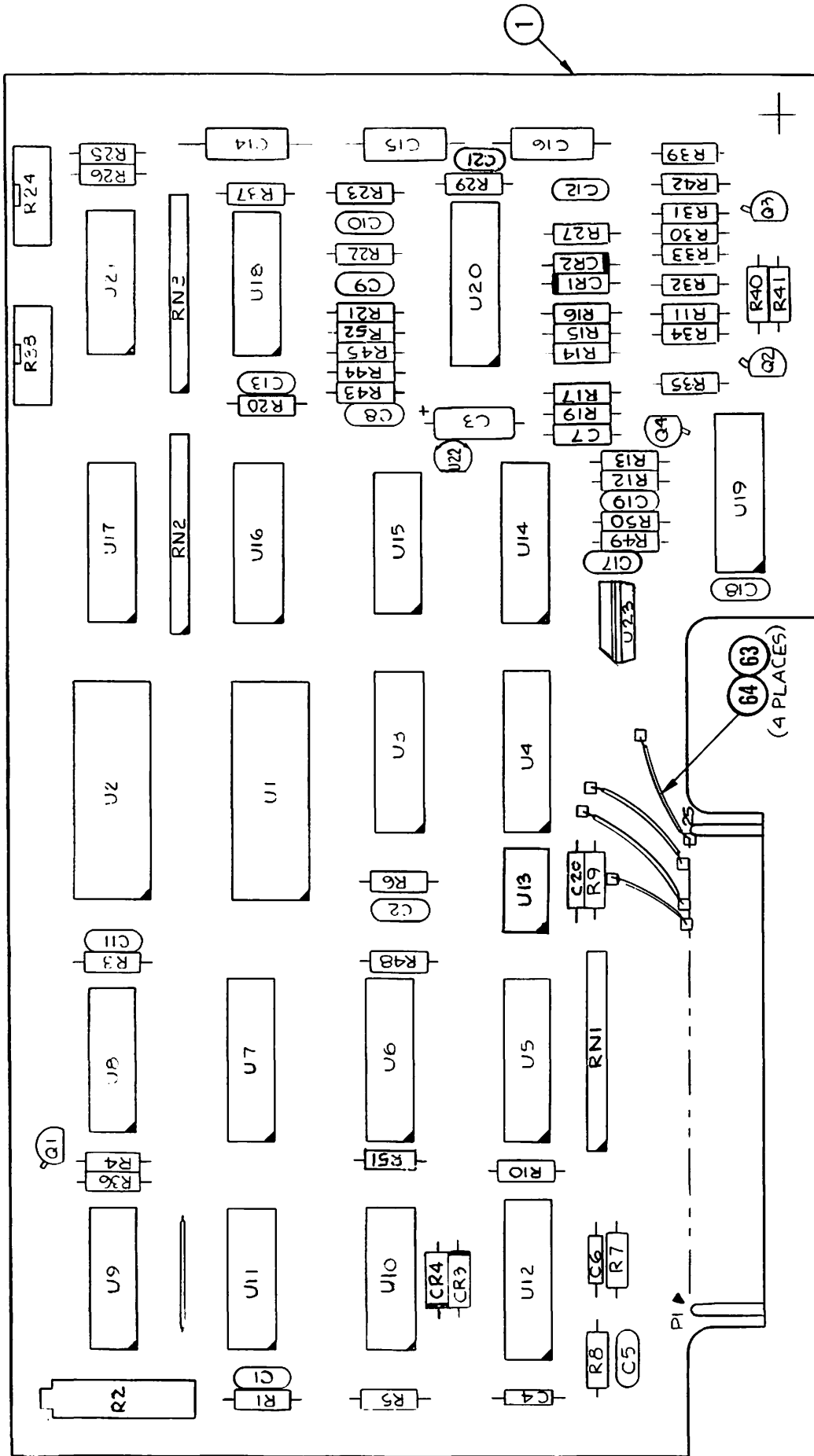

SEMICONDUCTOR BASE DIAGRAM. B.C. 3

800159

Figure 5-7 No-Fade PCB Assembly

## PARTS LIST



FIG AND ITEM No.	REF. DES.	PCC PART No.	DESCRIPTION	UNITS PER ASSY	USED ON CODE
5-7					
1		800159-00	NO FADE PCB ASSY, LP/6 MON	REF	
2	C1	02-12002-00	CAPACITOR, CER, 10pf/1KV	1	
3	C2	200274-16	CAPACITOR, DM, 39pf/500	1	
4	C3	02-12600-00	CAPACITOR, TANT, 1uf/50	1	
5			DELETED		
6	C5,11	200264-26	CAPACITOR, MON CER, 2.2uf/50	2	
7	C6	200049-07	CAPACITOR, CER, 220pf/50	1	
8	C20	200049-15	CAPACITOR, CER, 1,000pf/50	1	
9	C8,9	200274-38	CAPACITOR, DM, 330pf/500	2	
10	C10	200274-10	CAPACITOR, DM, 22pf/500	1	
11	C12	02-12026-00	CAPACITOR, CER, 470pf/1KV	1	
12	C13,17	02-12713-00	CAPACITOR, DISC, 1uf/100	2	
13	C14	200211-81	CAPACITOR, POLYCARB, .01uf/200	1	
14	C15	200211-83	CAPACITOR, POLYCARB, .015uf/50	1	
15	C16	200211-121	CAPACITOR, POLYCARB, .0027uf/50	1	
16	C18,19	02-12048-00	CAPACITOR, CER, .01uf/500	2	
17	CR1,2, 3,4	02-14018-00	DIODE, 1N914B	4	
18	U1,2	200245-00	I.C., 4104	2	
19	U3,4	200244-00	I.C., CD4076	2	
20	U5,6,7	200063-00	I.C., MC14520B	3	
21	U8,15, 18	02-14439-00	I.C., CD4013	3	
22	U9	02-14426-00	I.C., 74C14	1	
23	U10	200221-00	I.C., CD4071	1	
24	U11	200183-00	I.C., CD4081	1	
25	U12	200207-01	I.C., CD4017	1	
26	U13	200327-00	I.C., CA3130	1	
27	U14	200045-00	I.C., CD4053B	1	



## PARTS LIST

FIG AND ITEM No.	REF. DES.	PCC PART No.	DESCRIPTION	UNITS PER ASSY	USED ON CODE
5-7					
28	U16,17	200165-00	I.C., MC14174	2	
29	U19,20	200199-00	I.C., TL084	2	
30	U21	200208-00	I.C., CD4068	1	
31	U22	200210-00	I.C., LM340LAZ-5	1	
32	U23	200209-08	I.C., LM320MP-5	1	
33	R2	02-11521-00	POT., 20TURN, 50K	1	
34	R24	02-11535-00	POT., 20K, 3/4TURN	1	
35	R38	02-11538-00	POT., 3/4TURN, 200K	1	
36	R1	200055-332	RESISTOR, MF, 28.7K, 1%, 1/8W	1	
37	1.	02-06092-00	RESISTOR, CF, 10K, 5%, 1/4W	11	
38	R7	02-06127-00	RESISTOR, CF, 300K, 5%, 1/4W	1	
39	R8	200055-434	RESISTOR, MF, 332K, 1%, 1/8W	1	
40	R9	02-06152-00	RESISTOR, CF, 3.3M, 5%, 1/4W	1	
41	R12	200055-288	RESISTOR, MF, 10K, 1%, 1/8W	1	
42	R13	200055-380	RESISTOR, MF, 90.9K, 1%, 1/8W	1	
43	R14,19	200055-384	RESISTOR, MF, 100K, 1%, 1/8W	3	
	23				
44	R15	200055-218	RESISTOR, MF, 1.82K, 1%, 1/8W	1	
45	R16	200055-222	RESISTOR, MF, 2K, 1%, 1/8W	1	
46	R17,6	02-06109-00	RESISTOR, CF, 51K, 5%, 1.4W	2	
47	R20	200055-313	RESISTOR, MF, 18.2K, 1%, 1/8W	1	
48	R21	200055-334	RESISTOR, MF, 30.1K, 1%, 1.8W	1	
49	R22	200055-284	RESISTOR, MF, 9.09K, 1%, 1.8W	1	
50	R25	02-06112-00	RESISTOR, CF, 68K, 5%, 1/4W	1	
51	2.	02-06099-00	RESISTOR, CF, 20K, 5%, 1/4W	6	
52	R27	02-06097-00	RESISTOR, CF, 16K, 5%, 1/4W	1	
53	R29	02-06078-00	RESISTOR, CF, 2.7K, 5%, 1/4W	1	
54	R36,37	02-06116-00	RESISTOR, CF, 100K, 5%, 1/4W	2	
55	R43,45	200055-413	RESISTOR, MF, 200K, 1%, 1/8W	2	
56	R44	200055-417	RESISTOR, MF, 221K, 1%, 1/8W	1	

## PARTS LIST

FIG AND ITEM No.	REF. DES.	PCC PART No.	DESCRIPTION	UNITS PER ASSY	USED ON CODE
5-7					
57	R48,49 50	02-06020-00	RESISTOR, CF, 10 OHM, 5%, 1/4W	3	
58	R52	200055-522	RESISTOR, MF, 2.8M, 1%, 1/8W	1	
59	RN1,2, 3	02-11186-01	RESISTOR LADDER 2R	3	
60	Q1	02-14573-00	TRANSISTOR 2N3903	1	
61	Q2,4	02-14611-00	TRANSISTOR PN2484	2	
62	Q3	02-14541-01	TRANSISTOR PN3962	1	
63		90-07028	TUBING, TEFLON #22	A/R	
64		90-09138	WIRE, BUSS #22	A/R	
65	C7	200049-20	CAPACITOR, CER, .0027ufd/50V	1	
66	C21	02-12084-00	CAPACITOR, 33pf/50V	1	
67	R60,61	02-06068-00	RESISTOR, CF, 1K, 5%, 1/4W	2	
68	CR5	02-14000-00	DIODE, 1N270	1	
		1. 	R3-5, R10, R11, R30, R32, R33, R40-42		
		2. 	R51, R26, R31, R34, R35, R39		

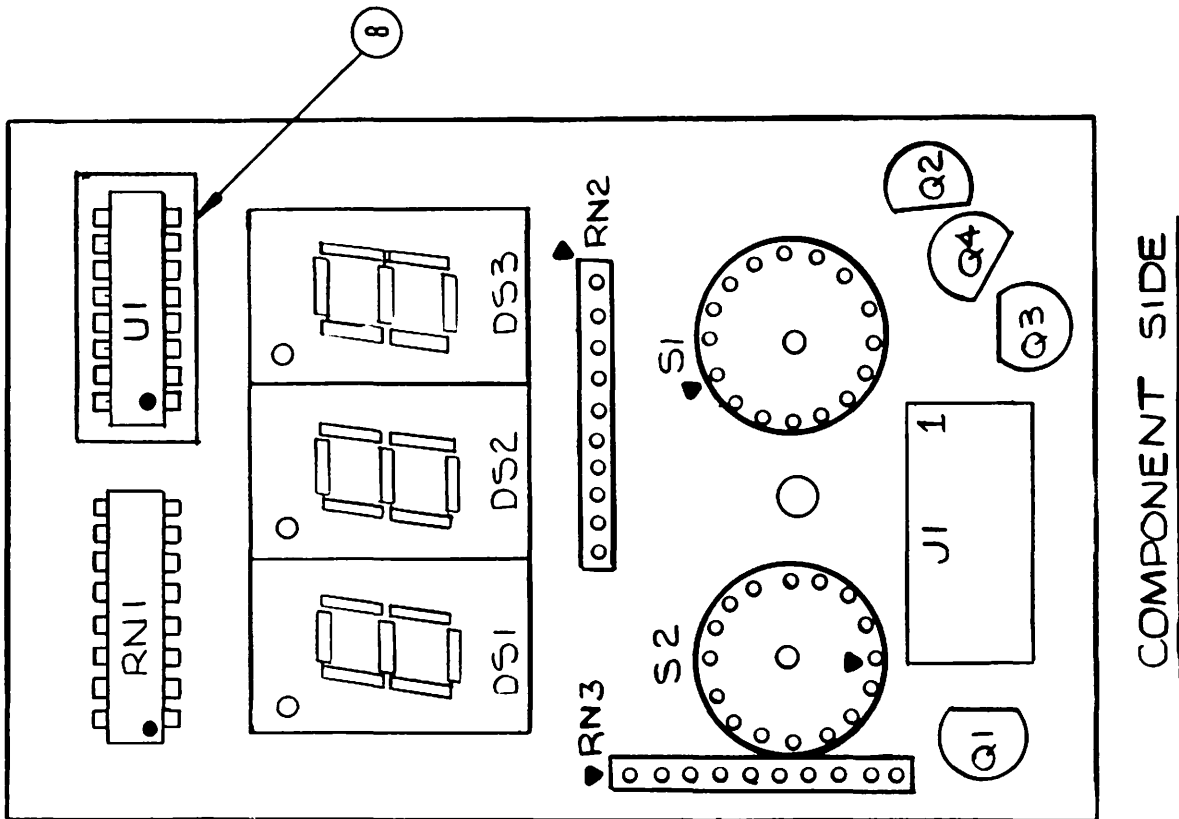
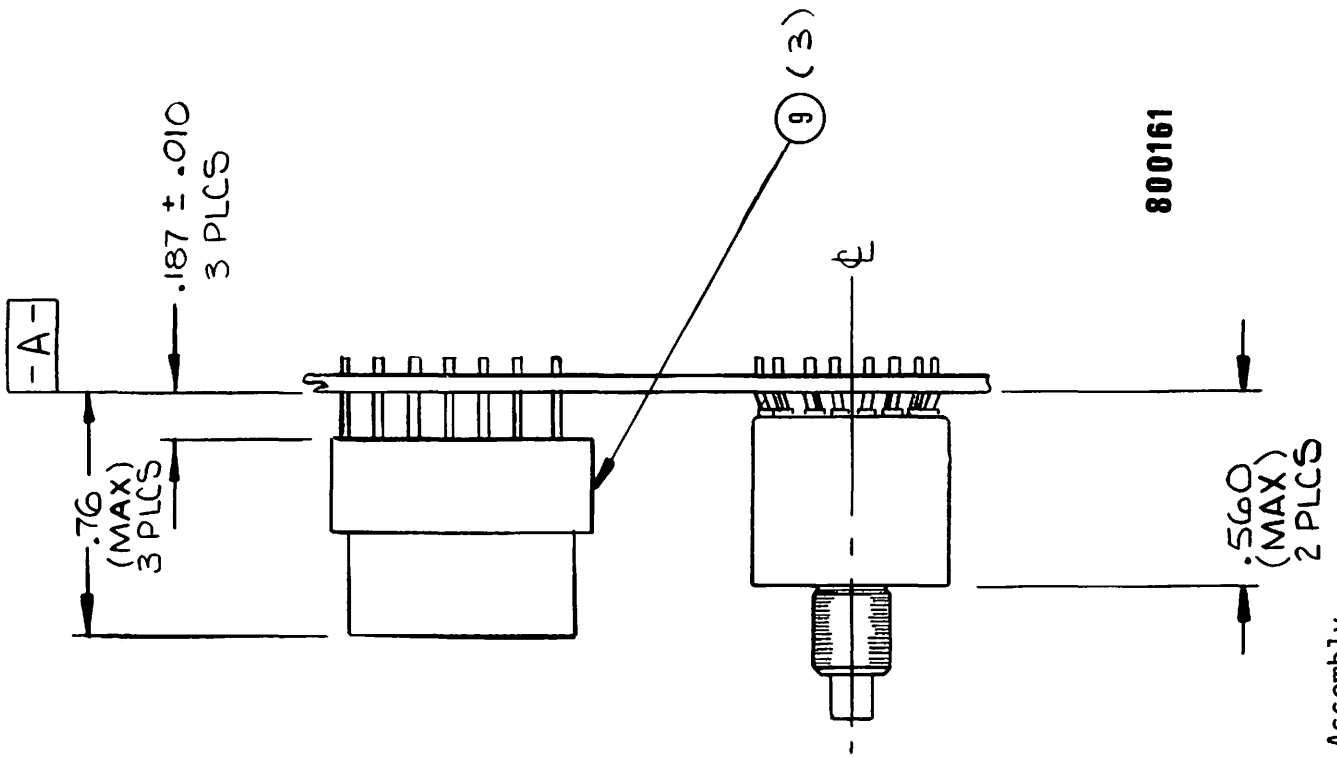
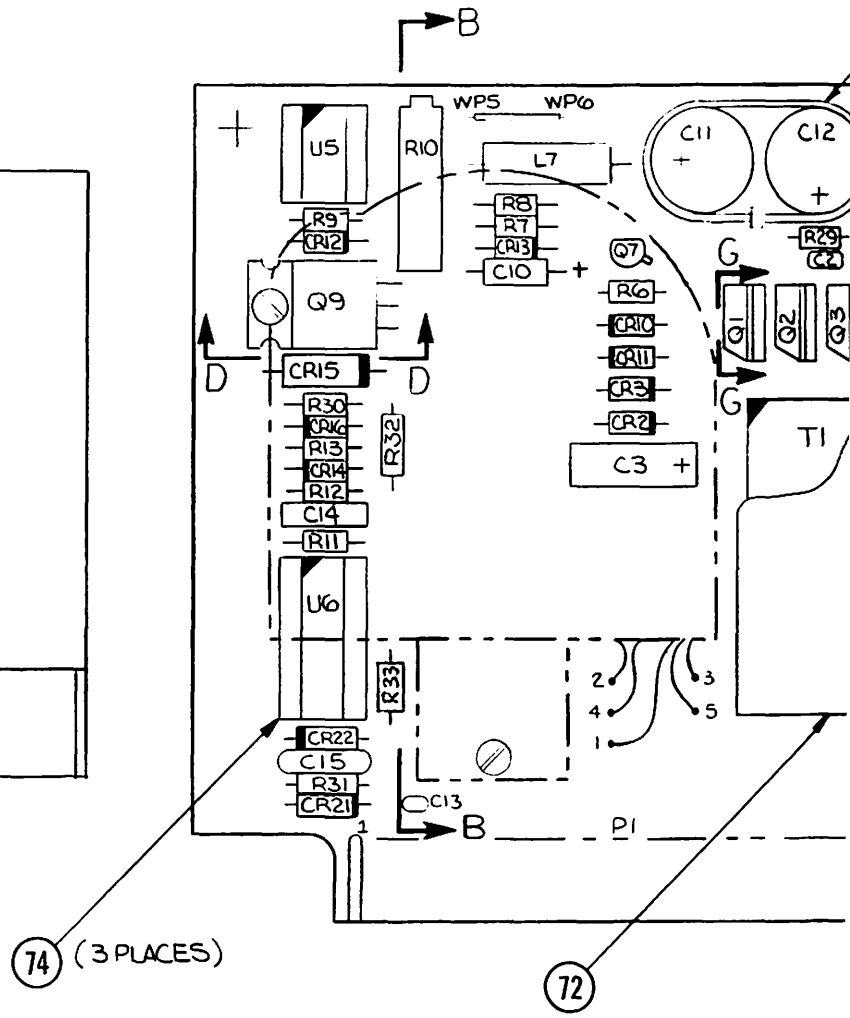
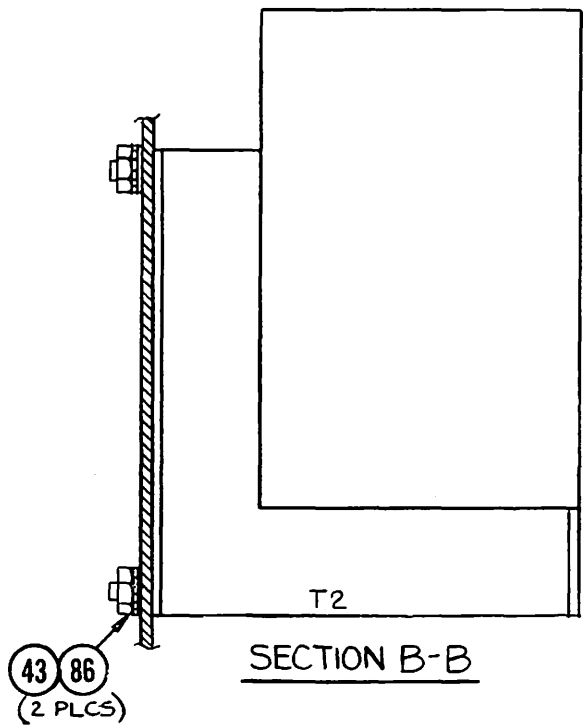
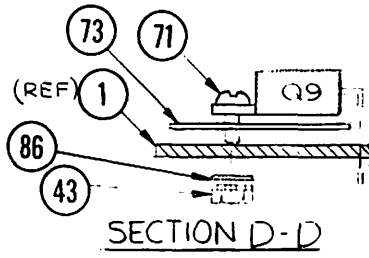

Figure 5-8 Display PCB Assembly

PARTS LIST

FIG AND ITEM No.	REF. DES.	PCC PART No.	DESCRIPTION	UNITS PER ASSY	USED ON CODE
5-8					
1		800161-00	DISPLAY BD ASSY MON. LP/6	REF	
2	DS1,2,3	200042-00	DISPLAY, 7 SEG, RED	3	
		1.			
3	U1	200111-00	I.C. 74C48	1	
4	RN1	200043-11	RESISTOR NETWORK 62 OHM	1	
5	RN2	800377-02	RESISTOR NETWORK	1	
6	RN3	800377-01	RESISTOR NETWORK	1	
7	J1	02-14311-00	SOCKET, 14 PIN DIP	1	
8		02-20266-00	SOCKET, 16 PIN DIP	1	
9		02-20305-00	SOCKET, 14 PIN DIP	3	
10	S1,2	200167-08	SWITCH, 16 POS	2	
11	Q1,2,3,4	02-14541-01	TRANSISTOR PN3962	4	
		1.	ANY DASH NO., -00 THRU -05 MAY BE USED AS LONG AS EACH UNIT HAS THREE OF THE SAME DASH NO.		



5-28

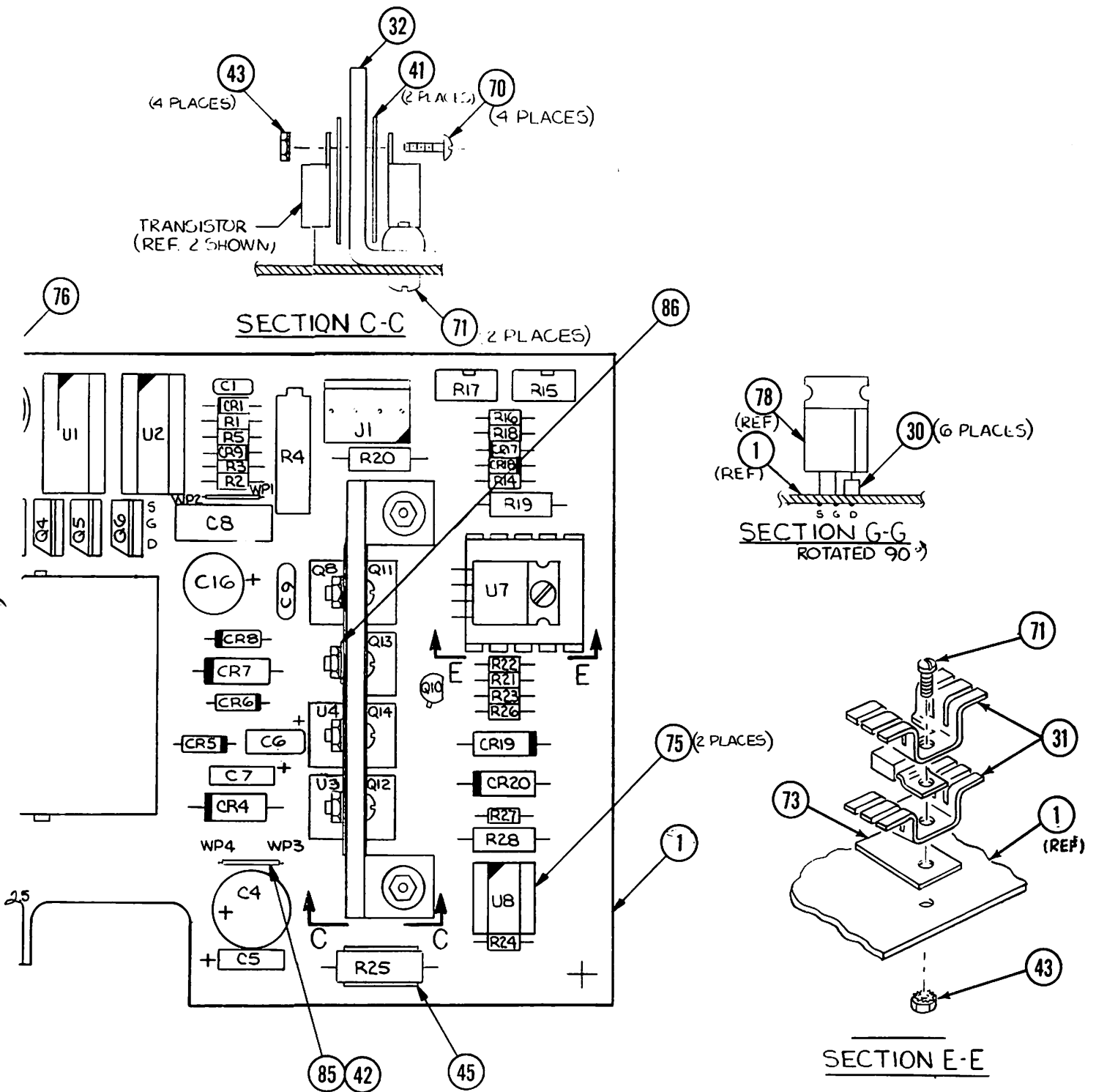

800112

Figure 5-9 Power Supply PCB Assembly

5-28/5-29

5-29

## PARTS LIST

FIG AND ITEM No.	REF. DES.	PCC PART No.	DESCRIPTION	UNITS PER ASSY	USED ON CODE
5-9					
1		800112-00	PCB ASSY, POWER SUPPLY, MON	REF	
2	C1	02-12346-00	CAPACITOR, .1uf/50V	1	
3	C2,13	02-12097-00	CAPACITOR, NPO, .001uf/100V	2	
4	C3	02-12640-00	CAPACITOR, TANT, 47uf/25V	1	
5	C4	200322-04	CAPACITOR, ELECTLT, 270uf/25V	1	
6	C5	02-12743-00	CAPACITOR, TANT, 100uf/20V	1	
7	C6	02-12623-00	CAPACITOR, TANT, 10uf/35V	1	
8	C7	02-12663-00	CAPACITOR, TANT, 220uf/10V	1	
9	C8	02-12333-00	CAPACITOR, MYLAR, .1uf/100V	1	
10	C9	02-12317-00	CAPACITOR, MYLAR, .01uf/100V	1	
11	C10	02-12600-00	CAPACITOR, TANT, 1uf/50V	1	
12	C11,12	02-12738-00	CAPACITOR, ELECTLT, 820uf/15V	2	
13	C14	02-12399-00	CAPACITOR, MONO, .027uf/50V	1	
14	C15	02-12052-00	CAPACITOR, CERAMIC, .025uf/500V	1	
15	C16	02-12728-00	CAPACITOR, ELECTLT, 10uf/100V	1	
16	L7	02-18020-00	CHOKE, 500 mH	1	
17	J1	200096-02	CONN, MOLEX, 4 PIN	1	
18	CR1	02-14120-00	DIODE, 1N4743A	1	
19	CR2,3	02-14131-00	DIODE, 1N4754A	2	
20	CR4,7, 19,20	02-14028-00	DIODE, 3S1F1	4	
21	CR5	200083-00	DIODE, 1N5817	1	
22	CR8,16	02-14154-00	DIODE, MR818	2	
23	CR9,6	200234-24	DIODE, 1N981B	2	
24	CR10,11, 14	02-14152-00	DIODE, MR812	3	
25	CR12	02-14172-00	DIODE, 1N821	1	
26	CR13	02-14133-00	DIODE, 1N4751A	1	
27	CR15	200233-42	DIODE, 1N5375B	1	
28	CR17,18	02-14018-00	DIODE, 1N914B	2	

## PARTS LIST

FIG AND ITEM No.	REF. DES.	PCC PART No.	DESCRIPTION	UNITS PER ASSY	USED ON CODE
5-9					
29	CR21,22	200234-107	DIODE, 1N992	2	
30	L1,2,3, 4,5,6	02-18017-00	FERRITE BEAD	6	
31		200027-00	HEATSINK	1	
		200027-01	HEATSINK	1	
32		800271-01	HEATSINK, PC MOUNT	1	
33	U1	02-14426-00	I.C., 74C14	1	
34	U2	200182-00	I.C., 4013B	1	
35	U3	200209-04	I.C., LM320T-12	1	
36	U4	200227-00	I.C., LM340T-5	1	
37	U5	02-14348-00	I.C., LM741N	1	
38	U6	02-14437-00	I.C., 74C00	1	
39	U7	200056-00	I.C., uA759UIC	1	
40	U8	200254-03	I.C., LF255N	1	
41		800344-01	INSULATOR - HEATSINK	2	
42		90-09138	JUMPER, #22 BUSSWIRE	A/R	
43		90-03040	KEPNUT, 4-40x1/4ST	8	
44	T2	800464-01	MODULE ASSY, HI-VOLT	1	
45		90-09089	MOUNT, RESISTOR	1	
46	R4	02-11526-00	POT, 20TURN, 1M	1	
47	R10	02-11522-00	POT, 20TURN, 100K	1	
48	R15	02-11534-00	POT, 3/4TURN, 10K	1	
49	R17	02-11535-00	POT, 3/4TURN, 20K	1	
50	R1	02-06048-00	RESISTOR, CF, 150 OHM, 5%, 1/4W	1	
51	R2	02-06102-00	RESISTOR, CF, 27K, 5%, 1/4W	1	
52	R3	02-06106-00	RESISTOR, CF, 39K, 5%, 1/4W	1	
53	R5	02-06123-00	RESISTOR, CF, 200K, 5%, 1/4W	1	
54	R6	02-06061-00	RESISTOR, CF, 510 OHM, 5%, 1/4W	1	
55	R7	02-06069-00	RESISTOR, CF, 1.1K, 5%, 1/4W	1	
56	R8	200054-303	RESISTOR, MF, 14.3K, 1%, 1/8W	1	
57	R9,29	200054-305	RESISTOR, MF, 15K, 1%, 1/8W	2	



## PARTS LIST

FIG AND ITEM No.	REF. DES.	PCC PART No.	DESCRIPTION	UNITS PER ASSY	USED ON CODE
5-9					
58	1.	02-06092-00	RESISTOR, CF, 10K, 5%, 1/4W	5	
59	R12,14	02-06075-00	RESISTOR, CF, 2K, 5%, 1/4W	2	
60	R18	02-06099-00	RESISTOR, CF 20K, 5%, 1/4W	1	
61	R19	02-09006-00	RESISTOR, CC, 4.7OHM, 5%, 1/2W	1	
62	R20	02-09048-00	RESISTOR, CC, 270 OHM, 5%, 1/2W	1	
63	R22	02-06113-00	RESISTOR, CF, 75K, 5%, 1/4W	1	
64	R23	02-06060-00	RESISTOR, CF, 470 OHM, 5%, 1/4W	1	
65	R25	200270-24	RESISTOR, WW, 1 OHM, 5%, 2W	1	
66	R26,27	02-06036-00	RESISTOR, CF, 470HM, 5%, 1/4W	2	
67	R28	02-09022-00	RESISTOR, CC, 220HM, 5%, 1/2W	1	
68	R30,32	02-08161-00	RESISTOR, CC, 5.1M 5%, 1/4W	1	
69	R31	02-06147-00	RESISTOR, CF, 2M, 5%, 1/4W	1	
70		90-01169	SCREW, 4-40x3/4, PH, NYLON	4	
71		90-01191	SCREW, 4-40x5/16, PH, ST	4	
72		800558-00	SHIELD, TRANSFORMER	1	
73		90-09107	SILIPAD, TRANS	2	
74		200033-00	SOCKET, I.C., 14 PIN	3	
75		200033-02	SOCKET, I.C., 8 PIN	2	
76		90-10011	TIE WRAP, SM	1	
77	T1	800416-02	TRANSFORMER - LINEAR	1	
78	Q1-6	200299-00	TRANSISTOR, POW FET, VN66AF	6	
79	Q7	02-14573-00	TRANSISTOR, 2N3903	1	
80	Q8	02-14617-00	TRANSISTOR, D44H11	1	
81	Q9	200248-02	TRANSISTOR, D44E3	1	
82	Q10	02-14541-01	TRANSISTOR, PN3962	1	
83	Q11,13	200061-00	TRANSISTOR, RCA120	2	
84	Q12,14	200062-00	TRANSISTOR, RCA125	2	
85		90-07028	TUBING, TEFLON #22	A/R	
86		90-04051	WASHER, FLAT #4	4	
87	R33	02-06085-00	RESISTOR, CF, 5.1K, 5%, 1/4W	1	
88		90-03005	NUT, CP, 4-40 x 1/4 HEX	1	
		1.	R11, R13, R16, R21, R24		

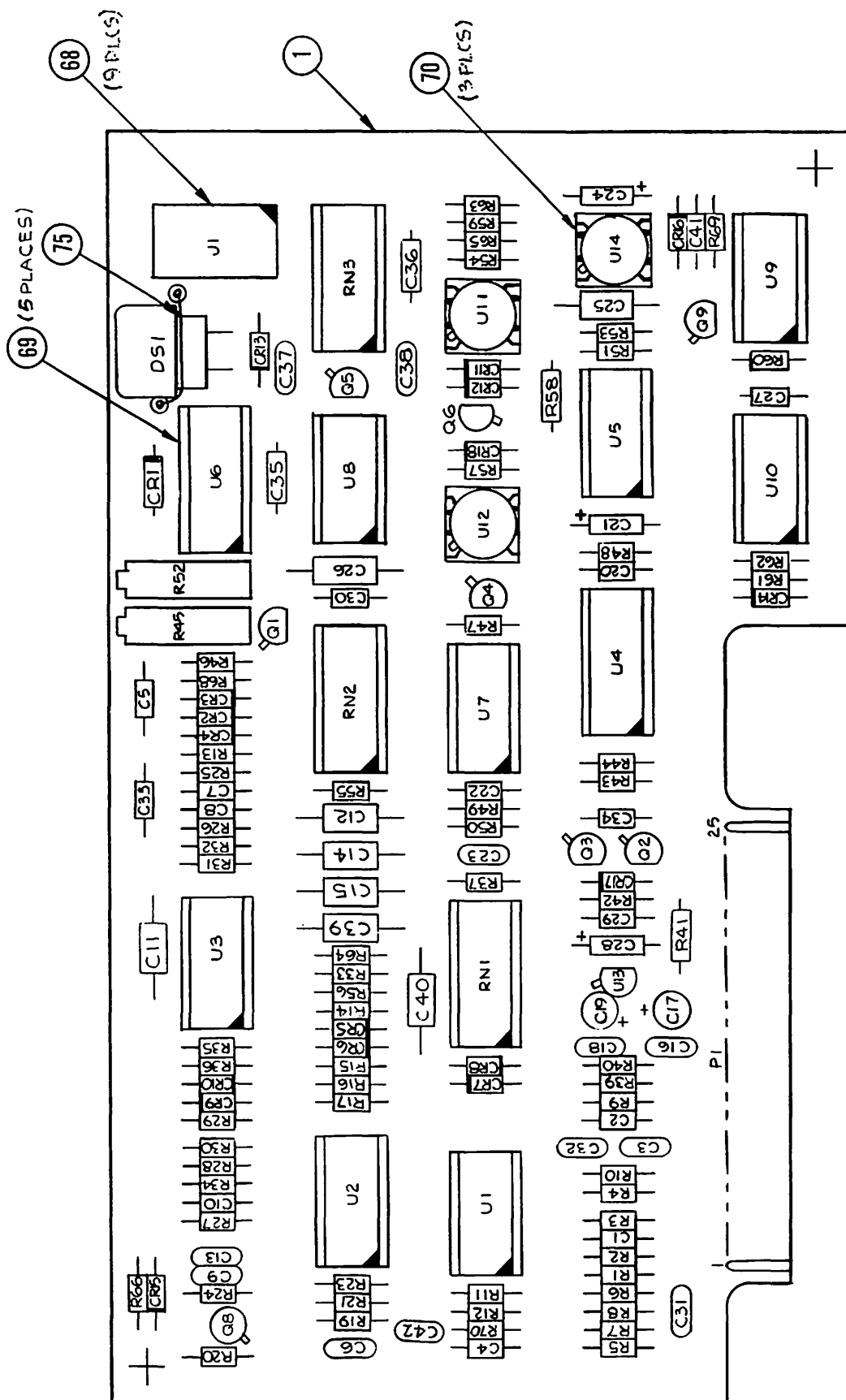

800053

Figure 5-10 Rate PCB Assembly

## PARTS LIST

FIG AND ITEM No.	REF. DES.	PCC PART No.	DESCRIPTION	UNITS PER ASSY	USED ON CODE
5-10					
1		800053-00	PCB ASSY, RATE BD, PP/6 MON	REF	
2	1.	200049-27	CAPACITOR, CER, 10,000pf/50V, 20%	7	
3	C3	200264-26	CAPACITOR, CER, 2.2MFD/50V	1	
4			DELETED		
5	2.	200211-05	CAPACITOR, POLYCARB, .10MFD/50V	11	
6	3.	02-12713-00	CAPACITOR, 1MFD/100V, 20%	5	
7	C7, 35,41	200049-15	CAPACITOR, CER, 1000pf/50V, 20%	3	
8	C10, 36	200049-39	CAPACITOR, CER, 100,000pf/50V, 20%	2	
9	C16,18	02-12048-00	CAPACITOR, CER DISC, .01MFD/500V	2	
10	C17,19	200280-63	CAPACITOR, TANT, 22MFD/35V	2	
11	C20	200049-31	CAPACITOR, CER, 22,000pf/50V, 20%	1	
12	C21	200109-73	CAPACITOR, TANT, 47MFD/50V, 10%	1	
13	C24,28	02-12606-00	CAPACITOR, TANT, 2.2/20V	2	
14	C31	02-12023	CAPACITOR, 330pf/1KV, 10%	1	
15	C32	02-12017-00	CAPACITOR, 200pf/1KV, 10%	1	
16			DELETED		
17	CR1-18	02-14018-00	DIODE, 1N914B	18	
18	U1,2,3	200287-00	I.C., TL064CN	3	
19	U4	200472-00	I.C., MC14538B	1	
20	U5	200093-00	I.C., CD4016AF	1	
21	U6	200066-00	I.C., MC14553B	1	
22	U7,10	02-14437-00	I.C., 74C00	2	
23	U8	02-14410-00	I.C., LM324N	1	
24	U9	200278-02	I.C., MC14007BCP	1	
25	U11,12	200048-00	I.C., CA3140S	2	
26	U13	200210-00	I.C., LM340LAZ-5	1	
27	U14	200048-01	I.C., CA3140AE	1	
28	R45,52	02-11526-00	POT, 20TURN, 1M	2	

## PARTS LIST

FIG AND ITEM No.	REF. DES.	PCC PART No.	DESCRIPTION	UNITS PER ASSY	USED ON CODE
5-10					
29	4.	02-06068-00	RESISTOR, CF, 1K, 5%, 1/4W	5	
30	R2	02-06118-00	RESISTOR, CF, 120K, 5%, 1/4W	1	
31	R3,6, 12	200055-288	RESISTOR, MF, 10K, 1%, 1/8W	3	
32	R4,29	02-06075-00	RESISTOR, CF, 2K, 5%, 1/4W	2	
33	R5	02-06044-00	RESISTOR, CF, 100 OHM, 5%, 1/4W	1	
34	R8	200055-272	RESISTOR, MF, 6.81K, 1%, 1/8W	1	
35	R9, 14, 15, 19	02-06099-00	RESISTOR, CF, 20K, 5%, 1/4W	4	
36	R10,28, 34	02-08160-00	RESISTOR, CC, 4.7M,5%, 1/4W	3	
37	R11	200055-222	RESISTOR, MF, 2K, 1%, 1/8W	1	
38	R13	02-06120-00	RESISTOR, CF, 150K, 5%, 1/4W	1	
39	R20	02-06078-00	RESISTOR, CF, 2.7K, 5%, 1/4W	1	
40	R21	020-06115-00	RESISTOR, CF, 91K, 5%, 1/4W	1	
41	R23	02-06108-00	RESISTOR, CF, 47K, 5%, 1/4W	1	
42	5.	02-06092-00	RESISTOR, CF, 10K, 5%, 1/4W	7	
43	R25	02-06147-00	RESISTOR, CF, 2M, 5%, 1/4W	1	
44	6.	02-06116-00	RESISTOR, CF, 100K, 5%, 1/4W	5	
45	R27	02-06148-00	RESISTOR, CF, 2.2M, 5%, 1/4W	1	
46	R31	200055-425	RESISTOR, MF, 267K, 1%, 1/8W	1	
47	R32	200055-470	RESISTOR, MF, 787K, 1%, 1/8W	1	
48	R33	200055-447	RESISTOR, MF, 453K, 1%, 1/8W	1	
49	R36	02-06079-00	RESISTOR, CF, 3K, 5%, 1/4W	1	
50	R37	200055-432	RESISTOR, MF, 316K, 1%, 1/8W	1	
51	R39,40	02-06012-00	RESISTOR, CF, 4.7 OHM, 5%, 1/4W	2	
52	R42	02-06106-00	RESISTOR, CF, 39K, 5%, 1/4W	1	
53	R43,51	02-06140-00	RESISTOR, CF, 1M, 5%, 1/4W	2	
54	R46	02-06156-00	RESISTOR, CF, 3.9M, 5%, 1/4W	1	

## PARTS LIST

FIG AND ITEM No.	REF. DES.	PCC PART No.	DESCRIPTION	UNITS PER ASSY	USED ON CODE
5-10			DELETED		
55					
56	R50	02-06137-00	RESISTOR, CF, 750K, 5%, 1/4W	1	
57	R53	02-06133-00	RESISTOR, CF, 510K, 5%, 1/4W	1	
58	R56	200055-396	RESISTOR, MF, 133K, 1%, 1/8W	1	
59	R57,47	02-06154-00	RESISTOR, CF, 100M, 5%, 1/4W	2	
60	R59	02-08176-00	RESISTOR, CC, 22M, 5%, 1/4W	1	
61	R61	02-06109-00	RESISTOR, CF, 51K, 5%, 1/4W	1	
62	R62	02-06089-00	RESISTOR, CF, 7.5K, 5%, 1/4W	1	
63	R64	200055-353	RESISTOR, MF, 47.5K, 1%, 1/8W	1	
64	R68	02-06122-00	RESISTOR, CF, 180K, 5%, 1/4W	1	
65	R69	02-06082-00	RESISTOR, CF, 3.9K, 5%, 1/4W	1	
66	RN1,2	200043-65	RESISTOR NETWORK, 10K	2	
67	RN3	200043-77	RESISTOR NETWORK, 100K	1	
68		200033-00	SOCKET I.E., 14 PIN	9	
69		200033-01	SOCKET I.C., 16 PIN	5	
70		200033-02	SOCKET I.C., 8 PIN	3	
71	DS1	200115-00	TRANSDUCER, AUDIO	1	
72	7.	02-14611-00	TRANSISTOR PN2484	5	
73	Q4,9	02-14541-01	TRANSISTOR PN3962	2	
74	Q3	200108-02	TRANSISTOR 2N4222	1	
75		90-09138	WIRE, #22 BUSS	A/R	
76	C27	02-12322-00	CAPACITOR, .022uf/100V, 10%	1	
77	C34	200049-07	CAPACITOR, 220pf/50V, 20%	1	
78	R49	200055-401	RESISTOR, MF, 150K, 1%, 1/8W	1	
79	R26,70	02-06123-00	RESISTOR, CF, 200K, 5%, 1/4W	2	
		1.	C1, C2, C4, C8, C15, C29, C30, C33		
		2.	C5, C11, C12, C14, C22, C23, C25, C26, C39, C40, C42		
		3.	C6, C8, C13, C37, C38		
		4.	R1, R7, R16, R17, R60		
		5.	R24, R30, R35, R54, R58, R63, R65		
		6.	R41, R44, R48, R55, R66		
		7.	Q1, Q2, Q3, Q5, Q6		

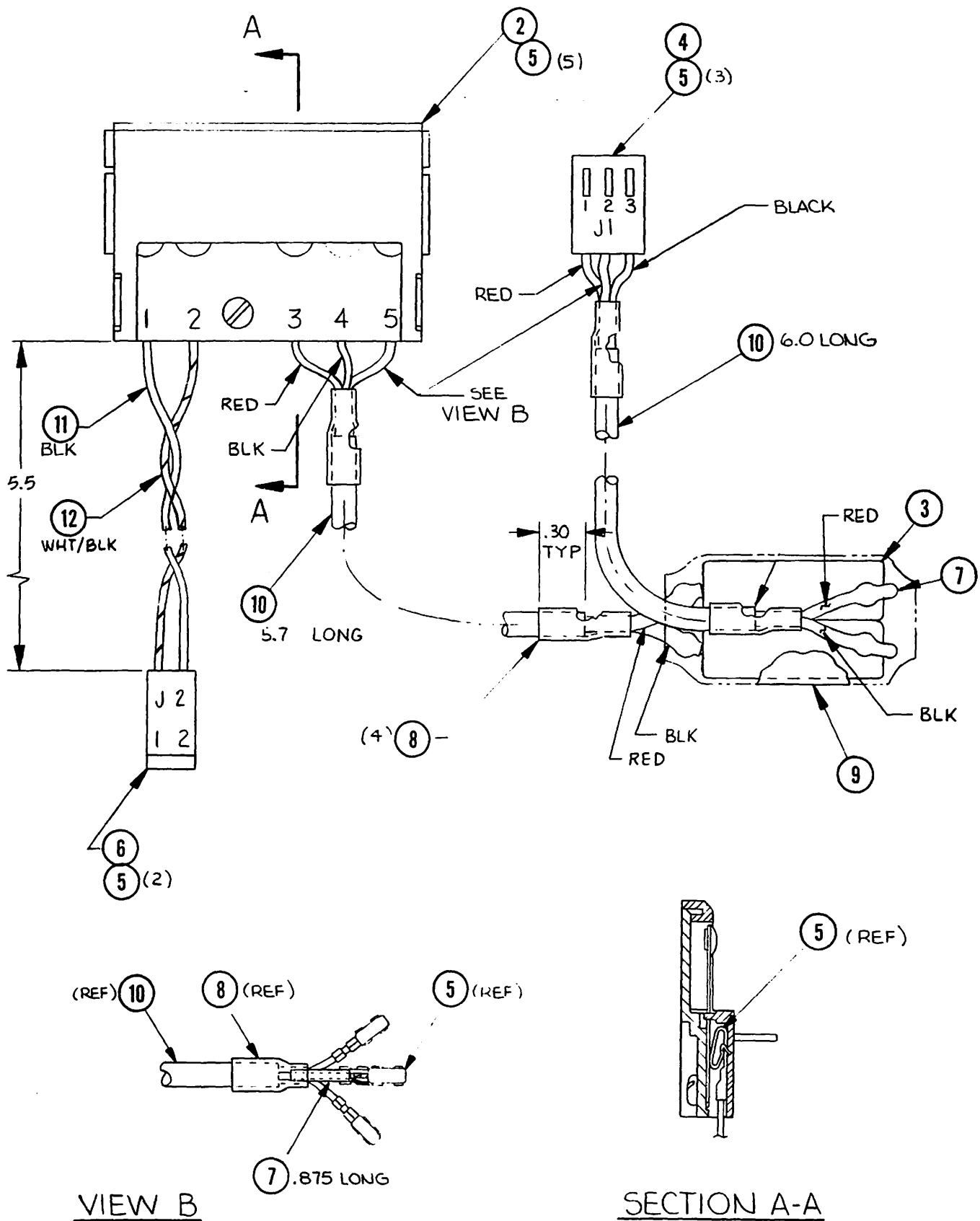
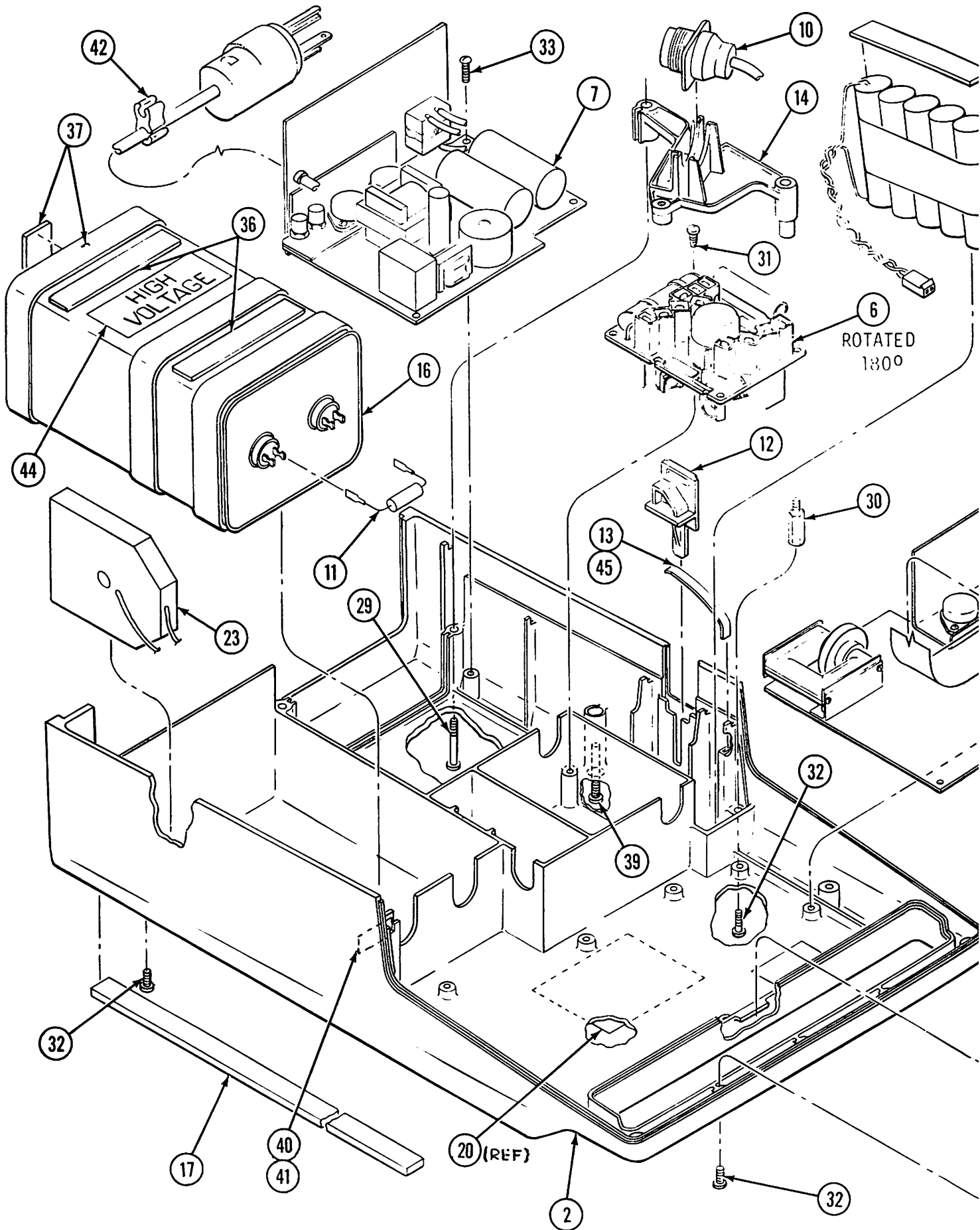

Figure 5-11 Interconnect Assembly

## PARTS LIST

FIG AND ITEM No.	REF. DES.	PCC PART No.	DESCRIPTION	UNITS PER ASSY	USED ON CODE
5-11					
1		800782-00	INTERCONNECT ASSY - MONITOR	REF	
2		800193-02	INTERCONNECT ASSY	1	
3		200406-01	FAULT INTERRUPTER-PATIENT LEAD ISOL.	1	
4	J1	02-20208-00	CONN - SHELL, 3 PIN	1	
5		02-20241-00	TERMINAL - CRIMP	10	
6	J2	02-20245-00	CONN - SHELL, 2 PIN	1	
7		90-07002	TUBING - SHRINK, BLACK 1/8	A/R	
8		90-07009	TUBING - SHRINK, CLEAR 1/4	A/R	
9		90-07016	TUBING - SHRINK, BLACK 3/4	A/R	
10		200404-42	WIRE - 2 COND SHLD, CSA/UL APPROVED	A/R	
11		200357-109	WIRE - 22 AWG, BLK, CSA/UL APPROVED	A/R	
12		200357-118	WIRE - 22 AWG, WHT/BLK, CSA/UL APPVD	A/R	





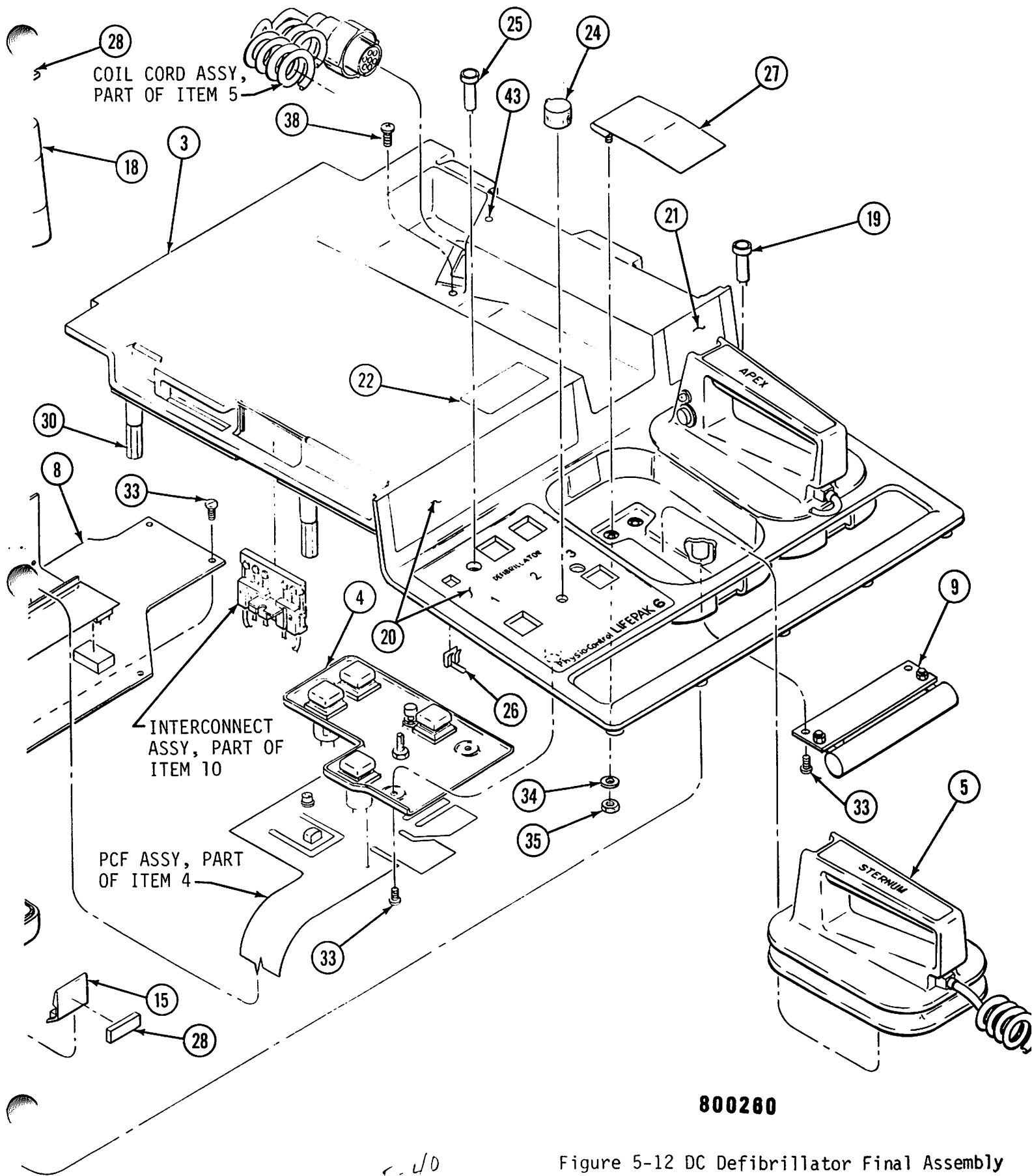

COIL CORD ASSY,  
PART OF ITEM 5

INTERCONNECT  
ASSY, PART OF  
ITEM 10

PCF ASSY, PART  
OF ITEM 4

800280

Figure 5-12 DC Defibrillator Final Assembly

5-39/5-40

Jan 1979

5-40

## PARTS LIST

FIG AND ITEM No.	REF. DES.	PCC PART No.	DESCRIPTION	UNITS PER ASSY	USED ON CODE
5-12					
1		800260-00	DEFIB FINAL ASSY LP6	REF	
2		800189-01	CASE - LOWER ASSY, PAINTED	1	
3		800188-01	CASE - UPPER ASSY/WITH PLUG	1	
4	A4	800381-00	CONTROL PANEL ASSY	1	
5		800250-00	PADDLE ASSY	1	
6	A3	800240-00	RELAY ASSY	1	
7	A2	800041-00	PCB ASSY - DEFIB CHARGER	1	
8	A1	800163-00	PCB ASSY - MAIN	1	
9		800167-00	PCB ASSY - TEST LOAD	1	
10	W1	800192-00	WIRING HARNESS	1	
11	R1	800516-00	RESISTOR ASSY	1	
12		800196-00	LATCH - CLOSURE	1	
13		800198-00	LATCH - SPRING	1	
14		800201-02	BRACKET ASSY - COIL CORD CONN	1	
15		800331-01	RETAINER - PADDLE	2	
16	C1	800339-01	CAPACITOR, 36 uf 5200 VDC	1	
17		800202-00	FOOT, MOUNTING	2	
18	B1	800566-00	BATTERY ASSY	1	
19		200130-00	LIGHT, LED, AMBER	1	
20		800513	LABEL MATRIX	---	
21		800213-01	LABEL - INSTR. TEST LOAD	1	
22		800216-00	LABEL - EXPLOSION HAZARD	1	
23	L1	800515-01	INDUCTOR, 28mH	1	
24		200126-01	KNOB - INSTRUMENTATION	1	
25		200130-01	LIGHT, LED, AMBER	1	
26		200162-01	FASTENER "U" RIGHT ANGLE	1	
27		01-41424-02	PLATE CONTACT	2	
28		90-08014	TAPE, FOAM RUBBER	A/R	
29		90-01239	SCREW, 6-32 x 1-3/8 BH, S, CP	1	
30		200192-26	STANDOFF 6-32 x 1" LONG	4	

## PARTS LIST

FIG AND ITEM No.	REF. DES.	PCC PART No.	DESCRIPTION	UNITS PER ASSY	USED ON CODE
5-12					
31		90-01242	SCREW 6-32 x 5/16 PH, ST, CP, S	4	
32		90-01058	SCREW 6-32 x 3/8 BH, S, CP	14	
33		90-01057	SCREW 6-32 x 5/16 BH, S, CP	16	
34		90-04010	WASHER, #6 FLAT	2	
35		90-03021	KEPNUT 6-32	4	
36		90-08029	TAPE, FOAM	A/R	
37		90-08010	TAPE, FOAM	A/R	
38		90-01061	SCREW 6-32 x 3/8 BH, S, BLK, OX.	1	
39		90-01183	SCREW 6-32 x 1-3/4 BH, S, CP	1	
40		90-10019	PANDUIT - MOUNT	1	
41		90-10011	TIE-WRAP SM	3	
42		800775-00	CLIP - CORD	1	
43		800746-00	TRIM POT	1	
44		01-50013-00	LABEL - HIGH VOLTAGE	1	
45		90-09035	RTV 102		

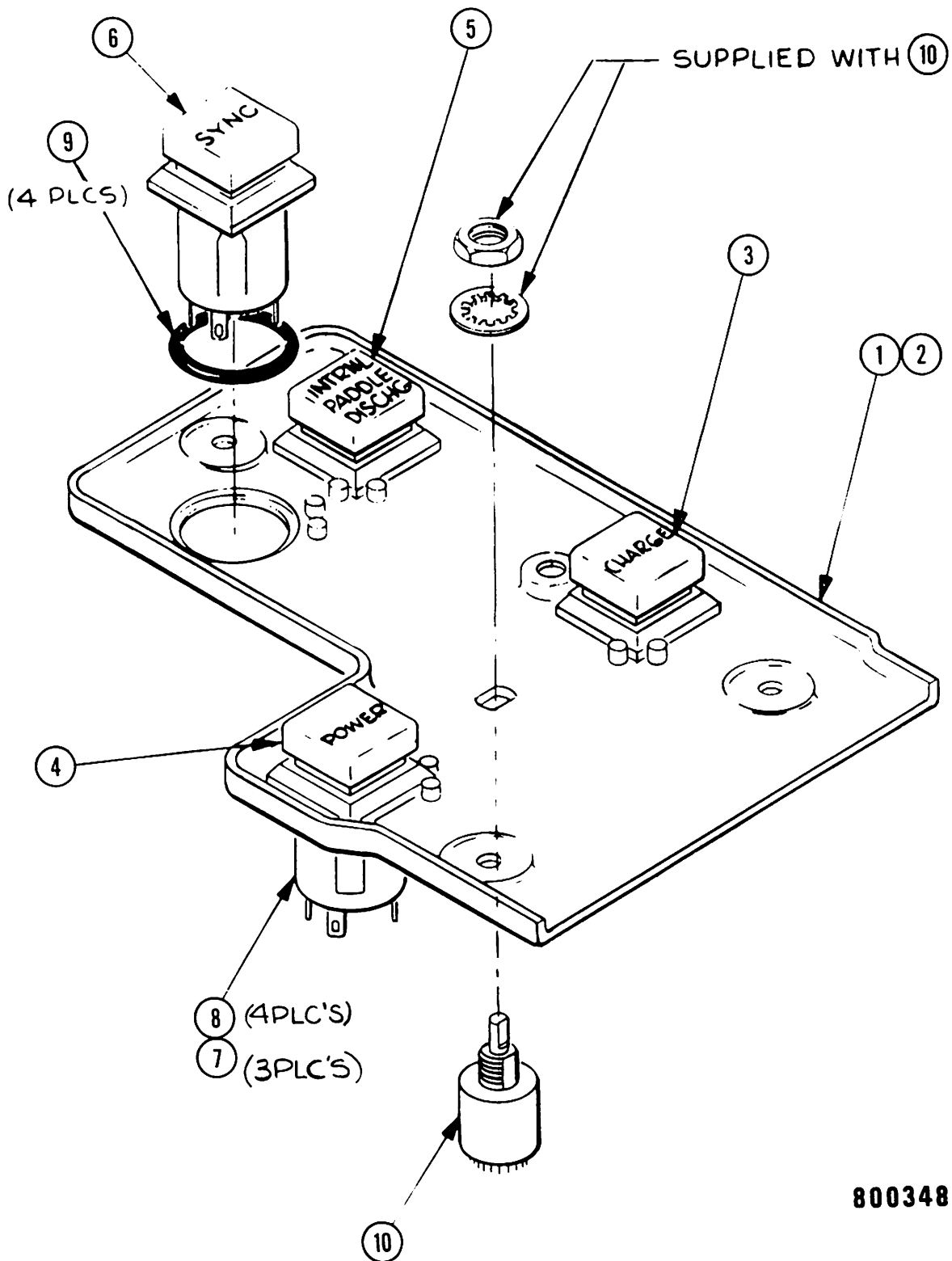

800348

Figure 5-13 Panel Assembly

## PARTS LIST

FIG AND ITEM No.	REF. DES.	PCC PART No.	DESCRIPTION	UNITS PER ASSY	USED ON CODE
5-13					
1		800348-00	PANEL ASSY DEFIB	REF	
2		800347-02	PANEL SWITCH SUPPORT	1	
3		800494-01	LENS SWITCH CAP RED ENGRAVED	1	
4		800494-02	LENS SWITCH CAP GRN ENGRAVED	1	
5		800494-03	LENS SWITCH CAP BLK ENGRAVED	1	
6		800494-00	LENS SWITCH CAP WHT ENGRAVED	1	
7		200132-00	LAMP MIDGET FLANGE T 1 3/4	3	
8		200128-00	SWITCH 1/2 AMP MOMENTARY	4	
9		200060-02	O-RING .676 DIA	4	
10		200151-07	SWITCH, ROTARY 9 POS.	1	

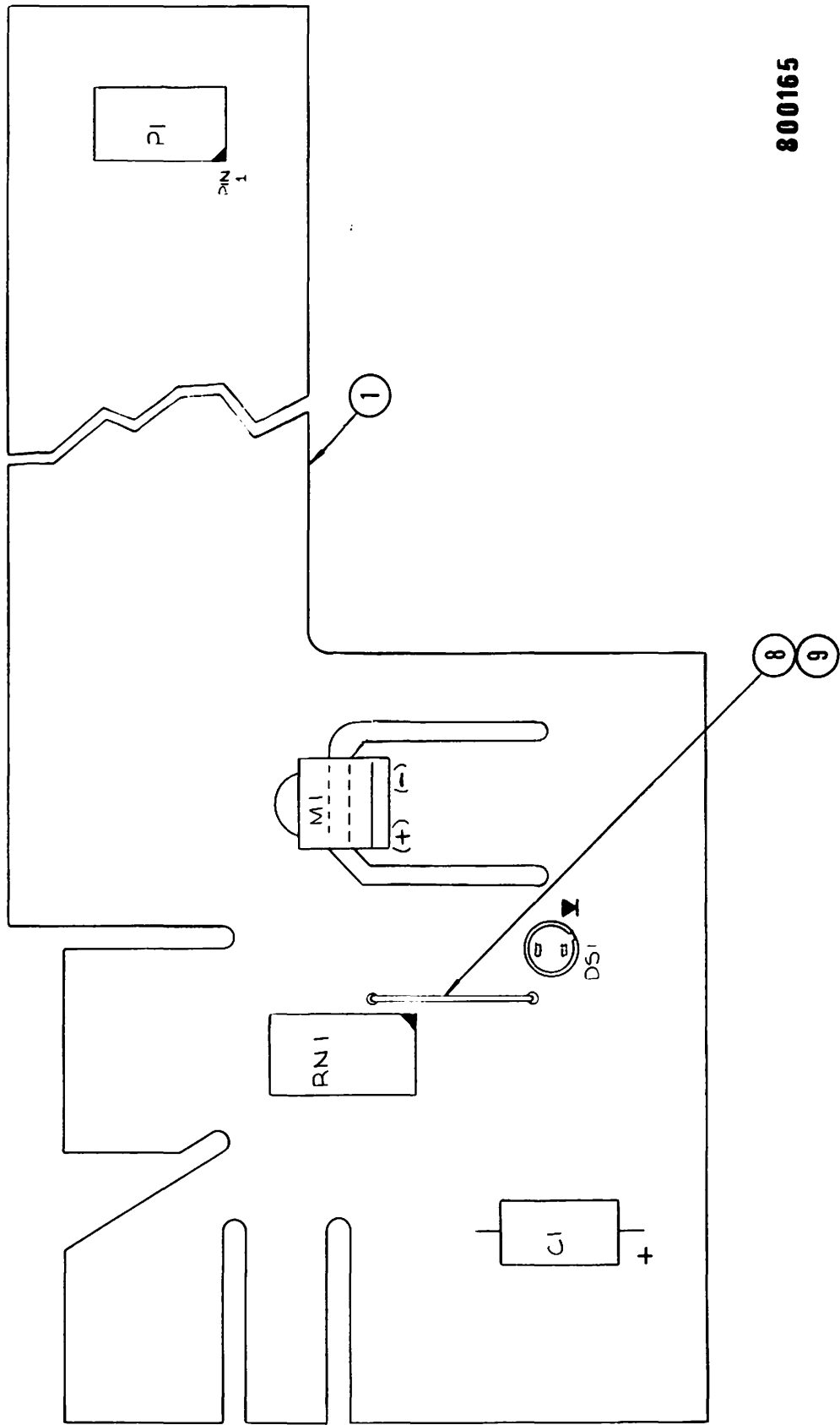

800165

Figure 5-14 Control Flex Assembly

## PARTS LIST

FIG AND ITEM No.	REF. DES.	PCC PART No.	DESCRIPTION	UNITS PER ASSY	USED ON CODE
5-14					
1		800165-00	CONTROL PANEL FLEX CIRC ASSY DEFIB	REF	
2		800164-00	FLEX CIRCUIT, CONTROL	1	
3	RN1	800395-00	RESISTOR NETWORK	1	
4	M1	200129-00	METER-MICROMINIATURE	1	
5	P1	200189-04	CONNECTOR, PCB MOUNT 14 PIN	1	
6	DS1	200127-00	SOCKET, L.E.D.	1	
7	C1	02-12631-00	CAPACITOR 25uf/25V	1	
8		90-09138	WIRE, #22 BUSS	A/R	
9		90-07028	TEFLON TUBING, #22	A/R	

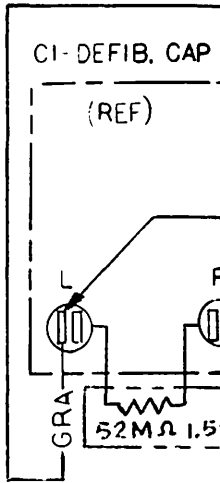
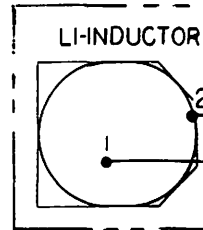
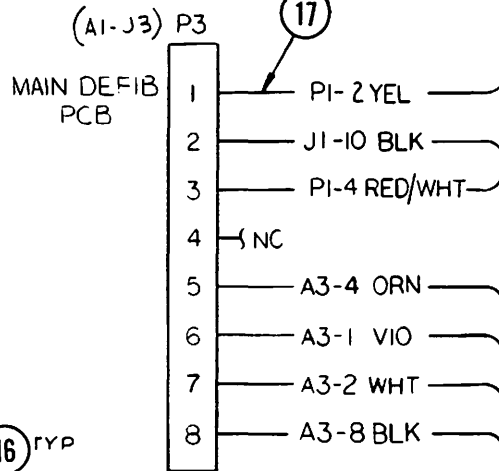
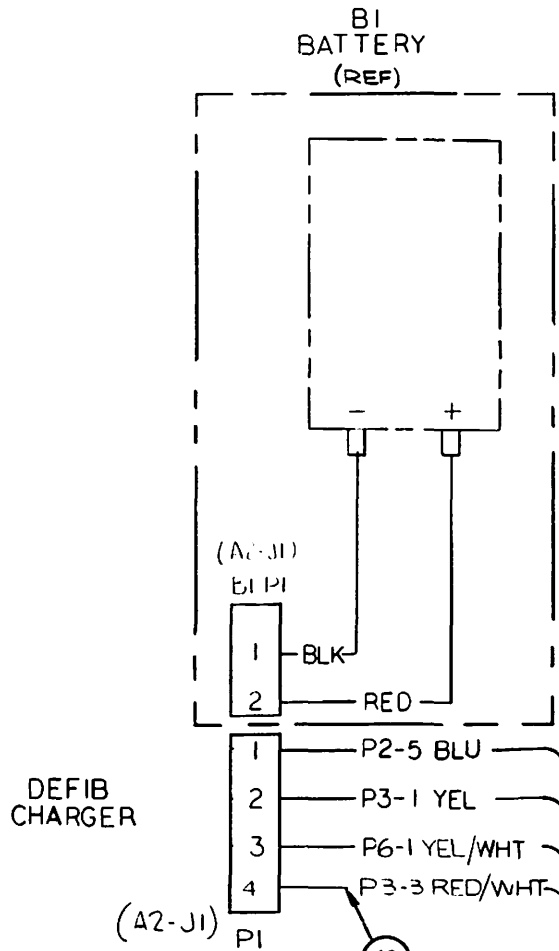
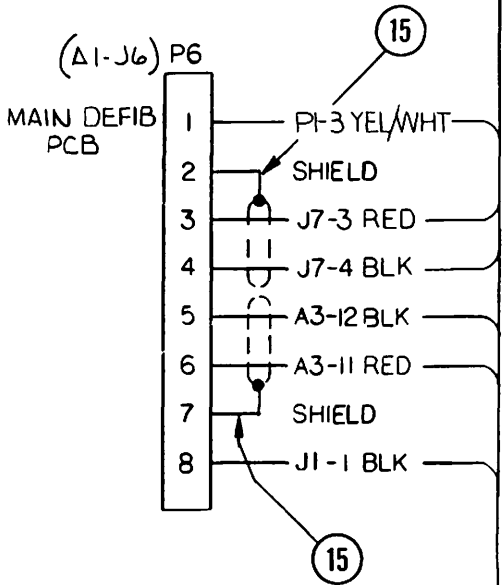
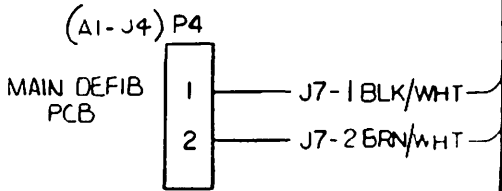
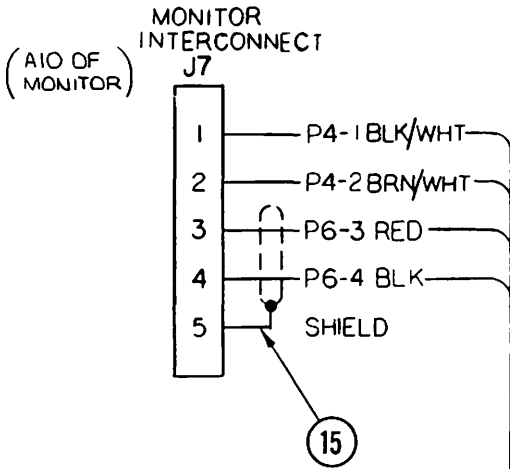



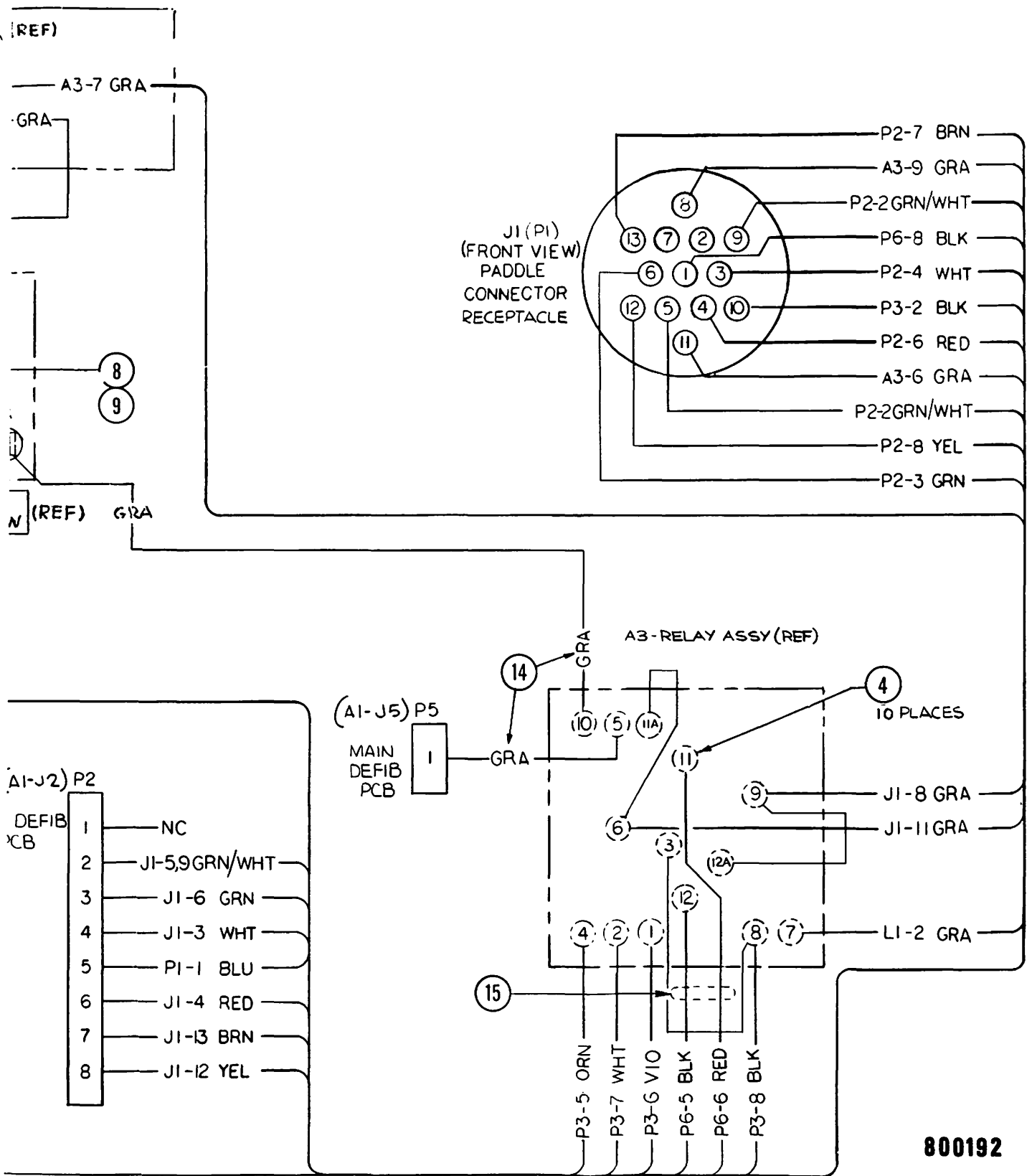

800192

5-48

Figure 5-15 Main Wire Harness Assembly

5-47/5-48

## PARTS LIST

FIG AND ITEM No.	REF. DES.	PCC PART No.	DESCRIPTION	UNITS PER ASSY	USED ON CODE
5-15					
1		800192-00	WIRING HARNESS DIAG DEFIB	REF	
2	J1	800466-00	PADDLE CONN 13 PIN RECEPT	1	
3	J7	800193-00	INTERCONNECT ASSY MON	1	
4		200267-00	SPADE LUG #22-18 INSULATED	10	
5	P2,3,6	02-20212-00	MOLEX CONN 8 PIN	3	
6	P1	02-20209-00	MOLEX CONN 4 PIN	1	
7	P4	02-20245-00	MOLEX CONN 2 PIN	1	
8		02-35527-00	LUG, FLAG 1/4" SPADE	2	
9		02-35528-00	HOUSING, RECEPTACLE	1	
10		02-20241-00	MOLEX CRIMP TERMINAL	25	
11		90-06053	HOUSING	1	
12		90-06063	LUG	1	
13		90-10011	TIE WRAP SMALL	A/R	
14		90-11096	WIRE, 10KV, #22 STRANDED	A/R	
15		90-11026	CABLE, 2 COND/SHLD	A/R	
16		S/S ALL COLORS	WIRE, #22 300V STRANDED	A/R	
17		90-11080	WIRE, #18, 300V, STR. YELLOW	A/R	
18		90-11084	WIRE, #18, 300V, STR. RED/WHT	A/R	

Figure 5-16 Charger PCB Assembly (Sht 1 of 2)

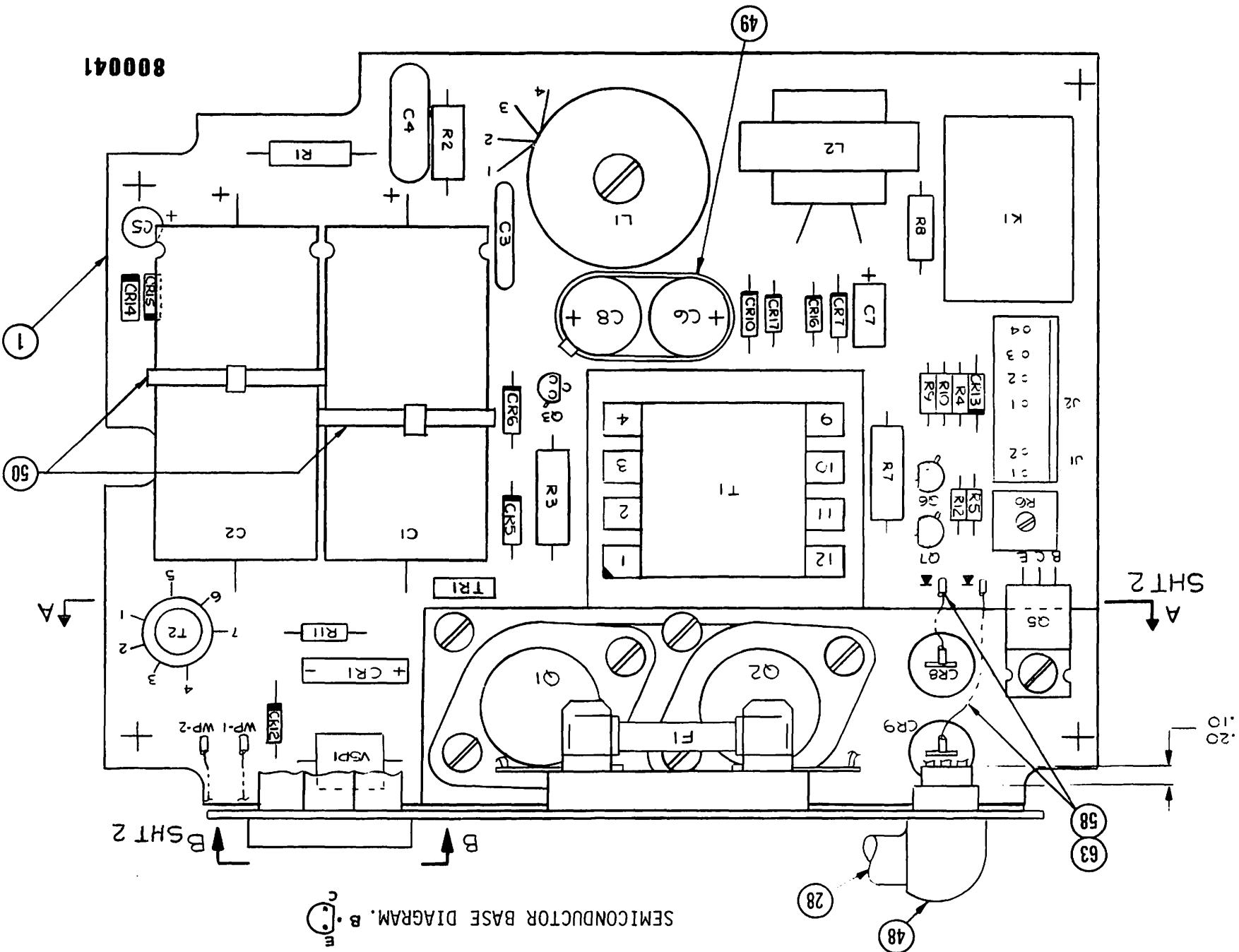

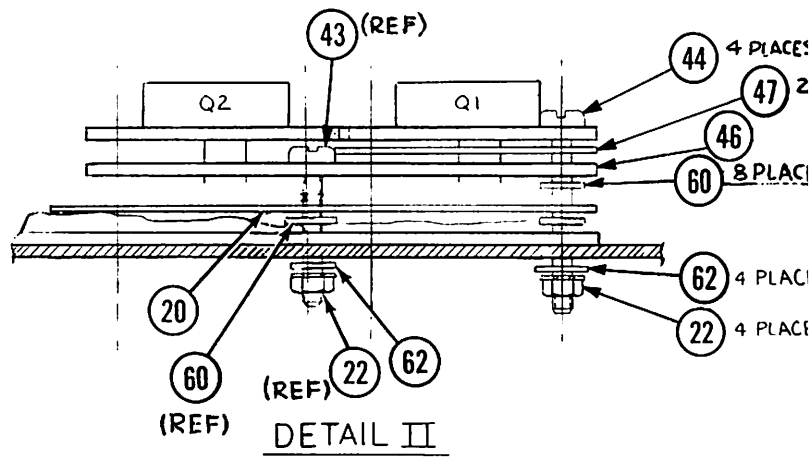
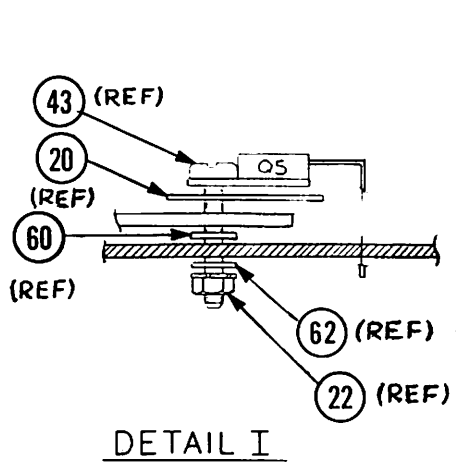
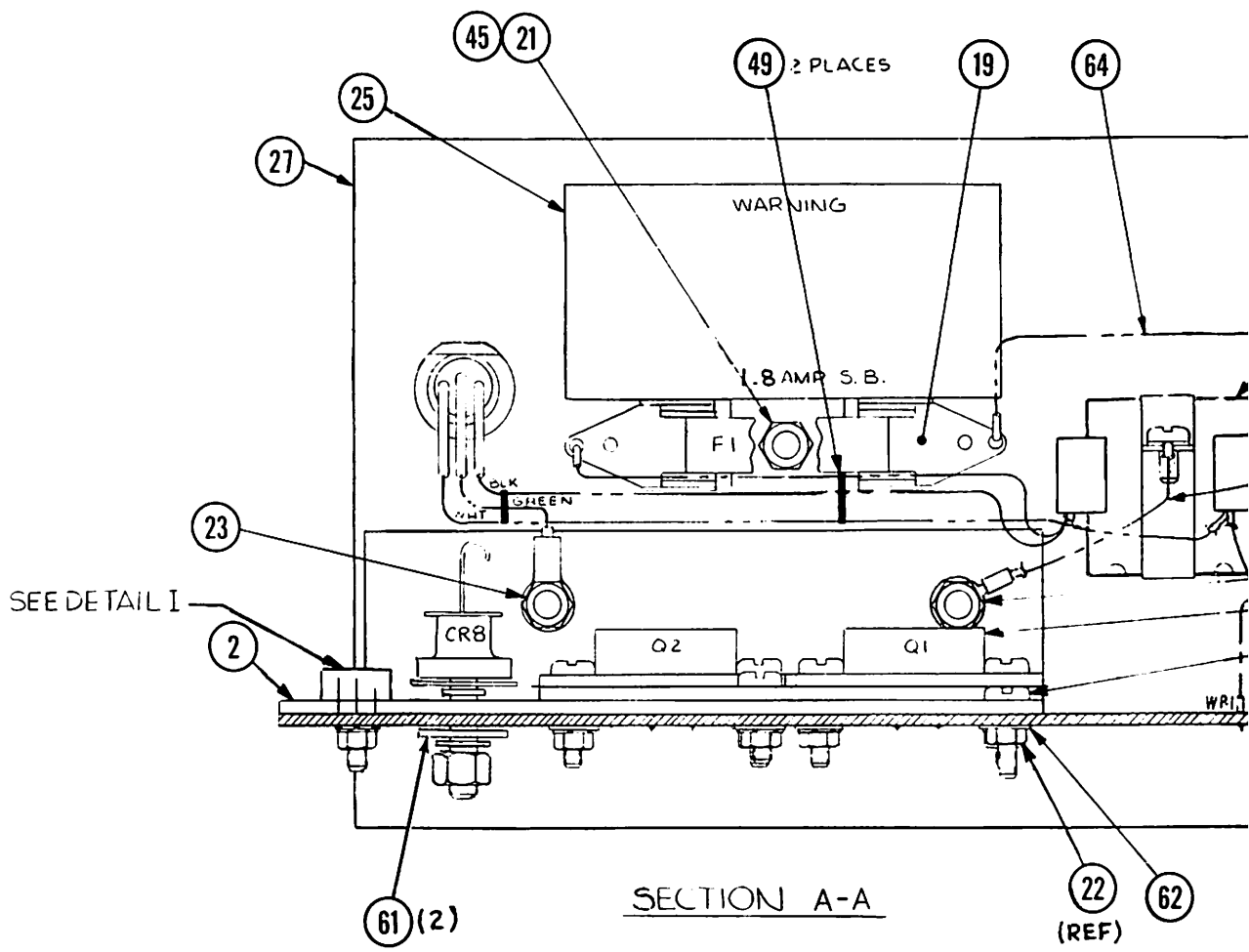

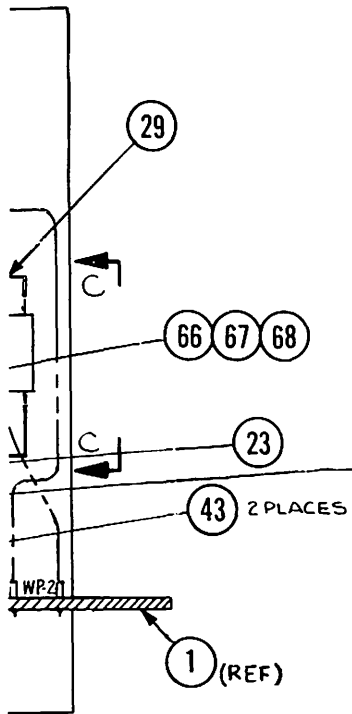

29 REF  
(ORIENT AS SHOWN)

SEE DETAIL II

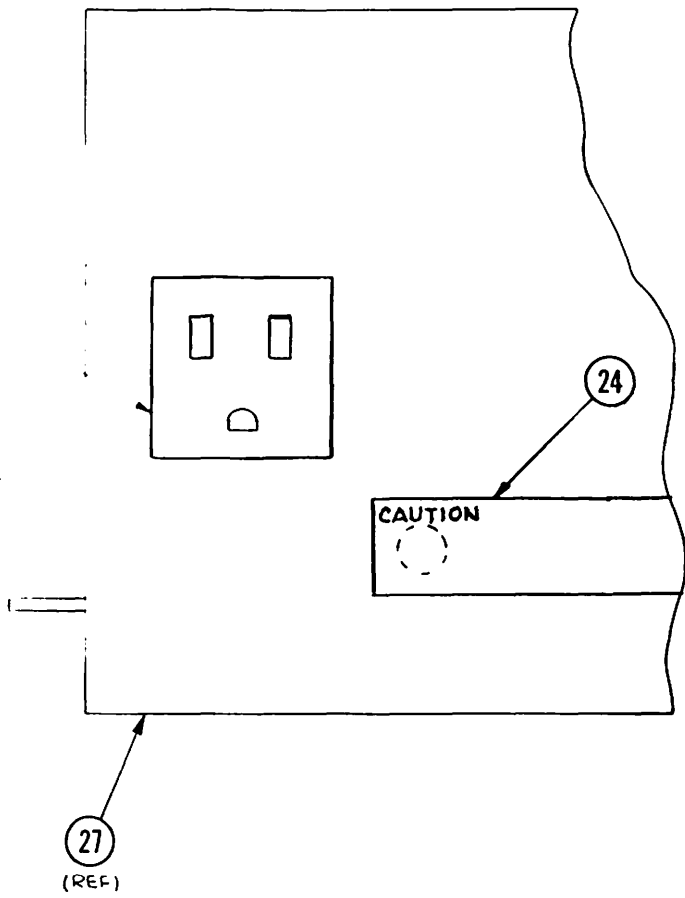

VIEW B-B

ES  
2 PLACES  
CES  
CES  
CES

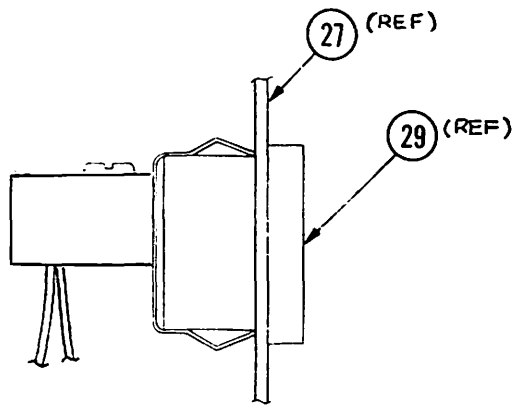

VIEW C-C

**800041**

Figure 5-16 Charger PCB Assembly (Sht 2 of 2)

5-52

5-51/5-52

Jan 19

## PARTS LIST

FIG AND ITEM No.	REF. DES.	PCC PART No.	DESCRIPTION	UNITS PER ASSY	USED ON CODE
5-16					
1		800041-00	ASSY, CHARGER PCB, DEFIB LP/6	REF	
2		800200-02	ANGLE-HEATSINK	1	
3	C1,2	200091-02	CAPACITOR, 260 $\mu$ f/180V	2	
4	C3	02-12046-00	CAPACITOR, .01 $\mu$ f/1KV	1	
5	C4	02-12324-00	CAPACITOR, .033 $\mu$ f/100V	1	
6	C5	200090-06	CAPACITOR, 330 $\mu$ f/3V	1	
7	C6	02-12729-00	CAPACITOR, 560 $\mu$ f/20V	1	
8	C7	02-12623-00	CAPACITOR, 10 $\mu$ f/35V	1	
9	C8	02-12727-00	CAPACITOR 22 $\mu$ f/100V	1	
10	L1	800210-00	INDUCTOR, R.F.I.	1	
11	L2	800328-00	CHOKE, FILTER	1	
12	CR1	02-14011-00	DIODE BRIDGE, KBP06	1	
13	CR5,6	02-14026-00	DIODE, 1N3470	2	
14	CR7,10 14,15	02-14152-00	DIODE MR812	4	
15	CR8,9	200088-09	DIODE, VSK3040S	2	
16	CR12,13	200284-05	DIODE, SILICON POW, 1N4005	2	
17	CR16,17	02-14133-00	DIODE, 1N4751	2	
18	F1	200256-116	FUSE, 1 8/10 AMP @ 125V, SLO BLO	1	
		200256-144	FUSE, 1 8/10 AMP @ 250V, SLO BLO	1	
19		02-22054-00	FUSE HOLDER	1	
20		800670-00	INSULATOR, HEATSINK	2	
21		90-03021	KEPNUT, #6-32 x 1/4	1	
22		90-03019	KEPNUT, #4-40 x 1/4	7	
23		90-03024	KEPNUT, #8-32 x 11/32	2	
24		800525-01	LABEL, CAUTION RECP'T	1	
25		800520-04	LABEL, FUSE (1-8/10 AMP)	1	
26	J1,2	02-20328-00	MOLEX CONN. 7 PIN, MALE	1	
27		800199-02	PLATE, HEATSINK	1	
28		800445-00	POWER CORD ASSY	1	
29		200135-00	RECEPTACLE, MIN. SNAP-IN	1	

## PARTS LIST

FIG AND ITEM No.	REF. DES.	PCC PART No.	DESCRIPTION	UNITS PER ASSY	USED ON CODE
5-16					
30	K1	800514-00	RELAY, 48VDC, SPDT	1	
31	R1	200120-98	RESISTOR, CC, 33K, 5%, 1W	1	
32	R2	200121-52	RESISTOR, WW, 200 OHM, 10%, 3W	1	
33	R3	200270-15	RESISTOR, WW, .43 OHM, 5%, 2W	1	
34	R4	02-06063-00	RESISTOR, CF, 620 OHM	1	
35	R5	02-06089-00	RESISTOR, CF, 7.5K, 5%, 1/4W	1	
36	R6	02-11548-00	RESISTOR, POT, 1K, 3/4T	1	
37	R7	200270-52	RESISTOR, WW, 15 OHM, 5%, 2W	1	
38	R8	02-09020-00	RESISTOR, CC, 18 OHM, 5%, 1/2W	1	
39	R9	02-06043-00	RESISTOR, CF, 91 OHM, 5%, 1/4W	1	
40	R10	02-06075-00	RESISTOR, CF, 2K, 5%, 1/4W	1	
41	R11	02-09077-00	RESISTOR, CC, 4.3K, 5%, 1/2W	1	
42	R12	020-06079-00	RESISTOR, CF, 3K, 5%, 1/4W	1	
43		90-01021	SCREW, 4-40 x 3/8, BH	3	
44		90-01028	SCREW, 4-40 x 1/2, BH	4	
45		90-01062	SCREW, 6-32 x 3/8, FH, P, BLK OX	1	
46		800227-00	SHIELD, HEATSINK	1	
47		90-09106	SILIPAD, TO-3	2	
48		200150-01	STRAIN RELIEF, RT. ANGLE	1	
49		90-10011	TIE WRAP, SM	3	
50		90-10012	TIE WRAP, LG	2	
51	T1	800209-00	TRANSFORMER, LIN. 110V	1	
52	T2	800329-00	TRANSFORMER, C.F.	1	
53	Q1,2	800180-00	TRANSISTOR DTS423	2	
54	Q3	200087-00	TRANSISTOR 2N4400	1	
55	Q5	02-14586-00	TRANSISTOR TIP115	1	
56	Q6	02-14606-00	TRANSISTOR PN2907A	1	
57	Q7	02-14607-00	TRANSISTOR PN2369A	1	
58		90-07039	TUBING, TEFLON, NO. 18	A/R	
59			DELETED		
60		90-04004	WASHER, FIBER #4	10	

## PARTS LIST

FIG AND ITEM No.	REF. DES.	PCC PART No.	DESCRIPTION	UNITS PER ASSY	USED ON CODE
5-16					
61		90-04065	WASHER, FLAT	2	
62		90-04008	WASHER, #4 x 5/16, FLAT	7	
63		90-09136	WIRE, NO. 18 BUSS	A/R	
64		200357-109	WIRE, STRAND, #22 BLK, PVC INS	A/R	
65	VSP1	200324-07	VOLTAGE SURGE PROTECTOR 2.5KV	1	
66		200357-57	WIRE, STRAND, #18 GRN, PVC INS	A/R	
67		90-06043	LUG, RING, #10	1	
68		90-06069	LUG, RING, #6	1	
69	TR1	200486-00	THERMISTOR, SURGE VOLT SG4	1	



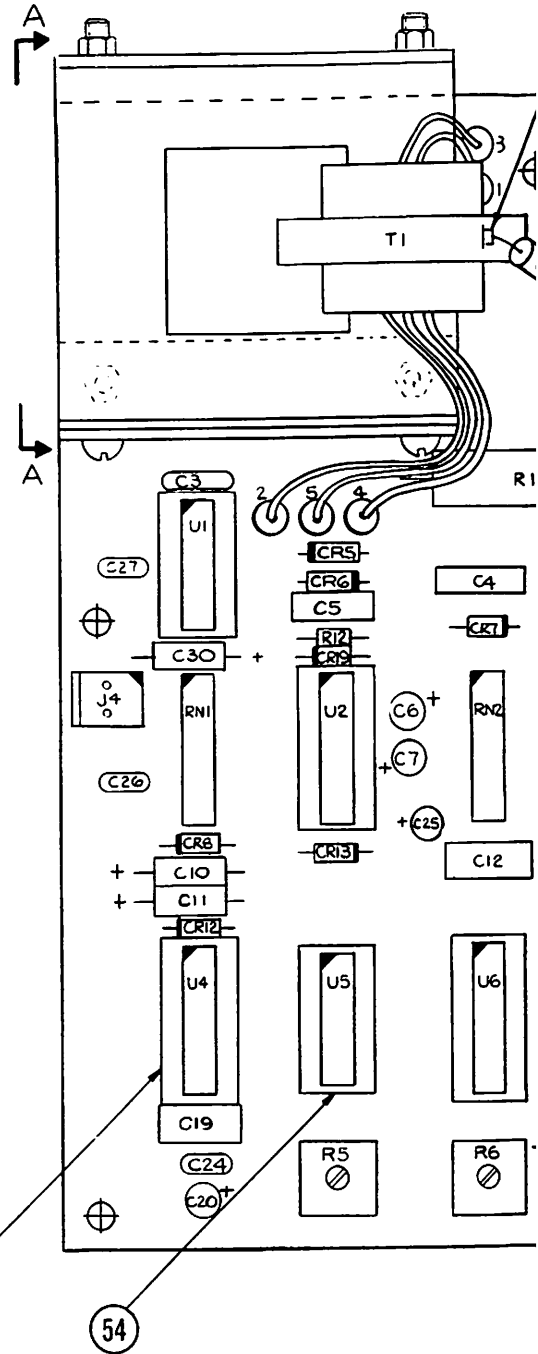
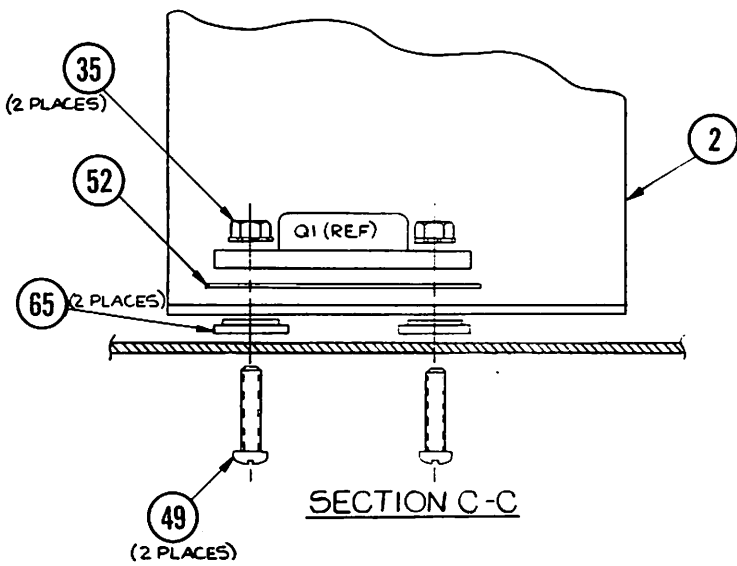
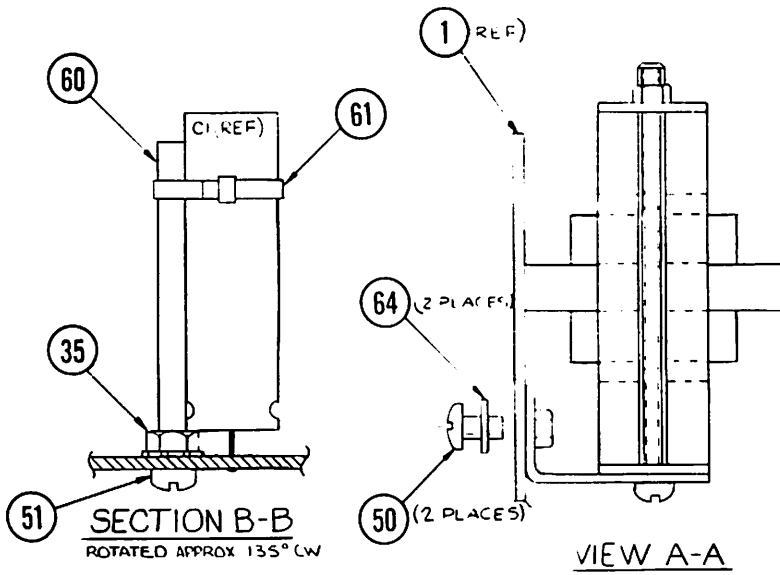

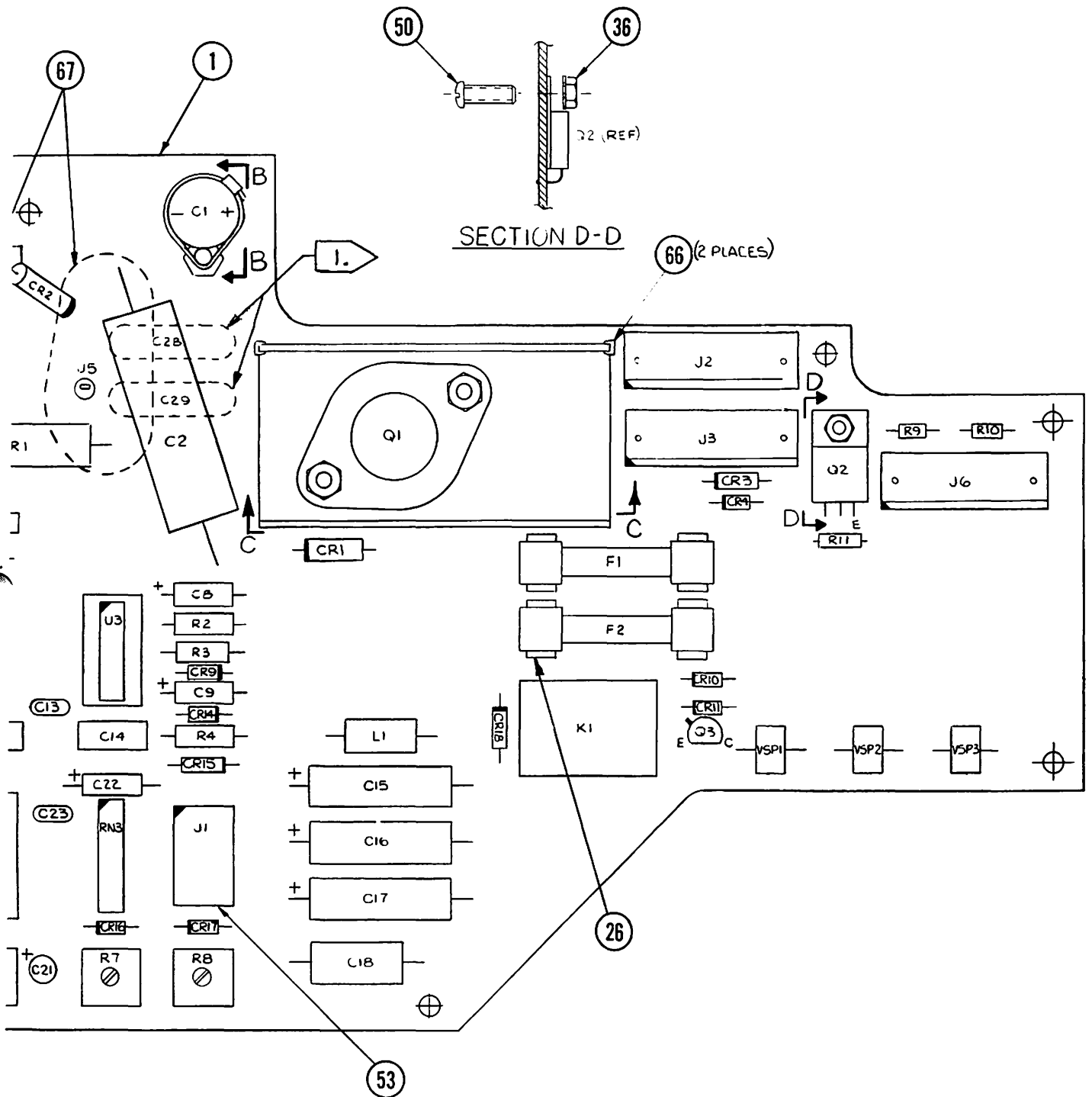

800163

5-57

Figure 5-17 Main PCB Assembly

5-56/5-57

## PARTS LIST

FIG AND ITEM No.	REF. DES.	PCC PART No.	DESCRIPTION	UNITS PER ASSY	USED ON CODE
5-17					
1		800163-00	MAIN PCB ASSY, DEFIB LP/6	REF	
2		800619-00	BRACKET, HEATSINK	1	
3	C1	02-12729-00	CAPACITOR, 560uf/20V	1	
4	C2 1.	200026-00	CAPACITOR, .01uf/8KV	1	
5	C3,13, 23,26	02-12048-00	CAPACITOR, .01uf/500V	4	
6	C4	02-12310-00	CAPACITOR, .0056uf/100V	1	
7	C6,7, 20,21	200280-63	CAPACITOR, 22uf/35V TANT 10%	4	
8	C8,9,10, 11,30	02-12606-00	CAPACITOR, 2.2uf/20V TANT	5	
9	C12,14, 19,5	02-12333-00	CAPACITOR, 0.1uf/100V, 10%	4	
10	C15,16, 17	02-12654-00	CAPACITOR, 100uf/25V	3	
11	C18	02-12286-00	CAPACITOR, .005uf/600V	1	
12	C22	200204-10	CAPACITOR, 22uf/10V	1	
13	C24	02-12037-00	CAPACITOR, .002uf/1KV	1	
14	C25	200205-00	CAPACITOR, 100uf/6.3V	1	
15	C27	02-12011-00	CAPACITOR, 100pf/1KV	1	
16	L1	02-18020-00	CHOKE 500 uH (0.4 OHM)	1	
17	J5	02-20171-00	CONNECTOR TERM, MALE 1 PIN	1	
18	J2,3,6	02-20329-00	CONNECTOR TERM, MALE 8 PIN	3	
19	J4	02-20323-00	CONNECTOR, MALE 2 PIN	1	
20	CR1	02-14162-00	DIODE 1N5373B	1	
21	CR2	02-14164-00	DIODE FAST RECOV., 25G20F (H.V.)	1	
22	CR3,7,16	200284-05	DIODE 1N4005	3	
23	2.	02-14018-00	DIODE 1N914B	11	
24	CR15,18	02-14144-00	DIODE 1N4745A	2	
25	CR17	200086-16	DIODE ZENER 1N4101	1	
26		02-35464-00	FUSE HOLDER, PCB	4	

## PARTS LIST

FIG AND ITEM No.	REF. DES.	PCC PART No.	DESCRIPTION	UNITS PER ASSY	USED ON CODE
5-17					
27	F1	200281-31	FUSE, 10A, 32V	1	
28	F2	200281-15	FUSE, 1/2A, 250V	1	
29	U1	02-14439-00	I.C., CD4013	1	
30	U2	800352-01	I.C., MONO-CHIP "A2", 1176	1	
31	U3	200084-00	I.C., CA3724G	1	
32	U4	800353-02	I.C., MONO-CHIP "F", 1175	1	
33	U5	200085-00	I.C., LM3086N	1	
34	U6	800351-01	I.C., MONO-CHIP "A1", 1185A	1	
35		90-03021	KEPNUT 6-32 x 1/4	3	
36		90-03019	KEPNUT 4-40 x 1/4	1	
37	K1	02-18569-01	RELAY (ON-OFF)	1	
38	R1	02-11189-00	RESISTOR 52 MEG, 1%, 1.5W, 7.5KV	1	
39	R2,3	02-09001-00	RESISTOR, CC, 3 OHM, 5%, 1/2W	2	
40	R4	02-09031-00	RESISTOR, CC, 51 OHM, 5%, 1/2W	1	
41	R5	02-11549-00	RESISTOR, POT. 2K, 3/4TURN	1	
42	R6,8	02-11551-00	RESISTOR, POT. 10K, 3/4TURN	2	
43	R7	02-11552-00	RESISTOR, POT. 20K, 3/4TURN	1	
44	R9, 10	02-08168-00	RESISTOR, CC, 10M, 5%, 1/4W	2	
45	R11	02-06075-00	RESISTOR, CF, 2K, 5%, 1/4W	1	
46	RN1	800407-00	RESISTOR NETWORK	1	
47	RN2	800408-01	RESISTOR NETWORK	1	
48	RN3	800409-01	RESISTOR NETWORK	1	
49		90-01070	SCREW 6-32 x 1/2 BH, CP	2	
50		90-01021	SCREW 4-40 x 3/8 BH, CP	3	
51		90-01183	SCREW 6-32 x 1-3/4 BH, CP	1	
52		90-09106	SILIPAD TO-3	1	
53	J1	200279-00	SOCKET, 14 PIN (ROUND PIN)	1	
54		200033-00	SOCKET, I.C., 14 PIN	3	
55		200033-01	SOCKET, I.C., 16 PIN	3	
56	Q1	02-14620-0A	TRANSISTOR, POWER STA7026	1	

## PARTS LIST

FIG AND ITEM No.	REF. DES.	PCC PART No.	DESCRIPTION	UNITS PER ASSY	USED ON CODE
5-17					
57	Q2	02-14617-00	TRANSISTOR D44H11	1	
58	Q3	02-14606-00	TRANSISTOR PN2907A	1	
59	T1	800411-01	TRANSFORMER, FLYBACK	1	
60		200283-04	TUBING, SHRINK 3/16"	A/R	
61		90-10011	TIE-WRAP SM	1	
62	VSP1	200324-11	VSP, 470V	1	
63	VSP2,3	200324-01	VSP, 90V	2	
64		90-04005	WASHER, LOCK I.T. #4	2	
65		02-35378-00	WASHER, SHOULDER NYLON	2	
66		02-35189-00	GROMMET, CATERPILLAR	A/R	
67		200321-00	TV CORONA DOPE GC #47-2	A/R	
68	R12	02-06133-00	RESISTOR, CF, 510K, 5%, 1/4W	1	
69	C28,29	02-12043-00	CAPACITOR, .0047/6KV	2	
	1.	C28 & C29	ARE ALTERNATE TO C2.		
	2.		CR4, CR5, CR6, CR8, CR9, CR10, CR11, CR12, CR13, CR14, CR19		

5-61

May 1978

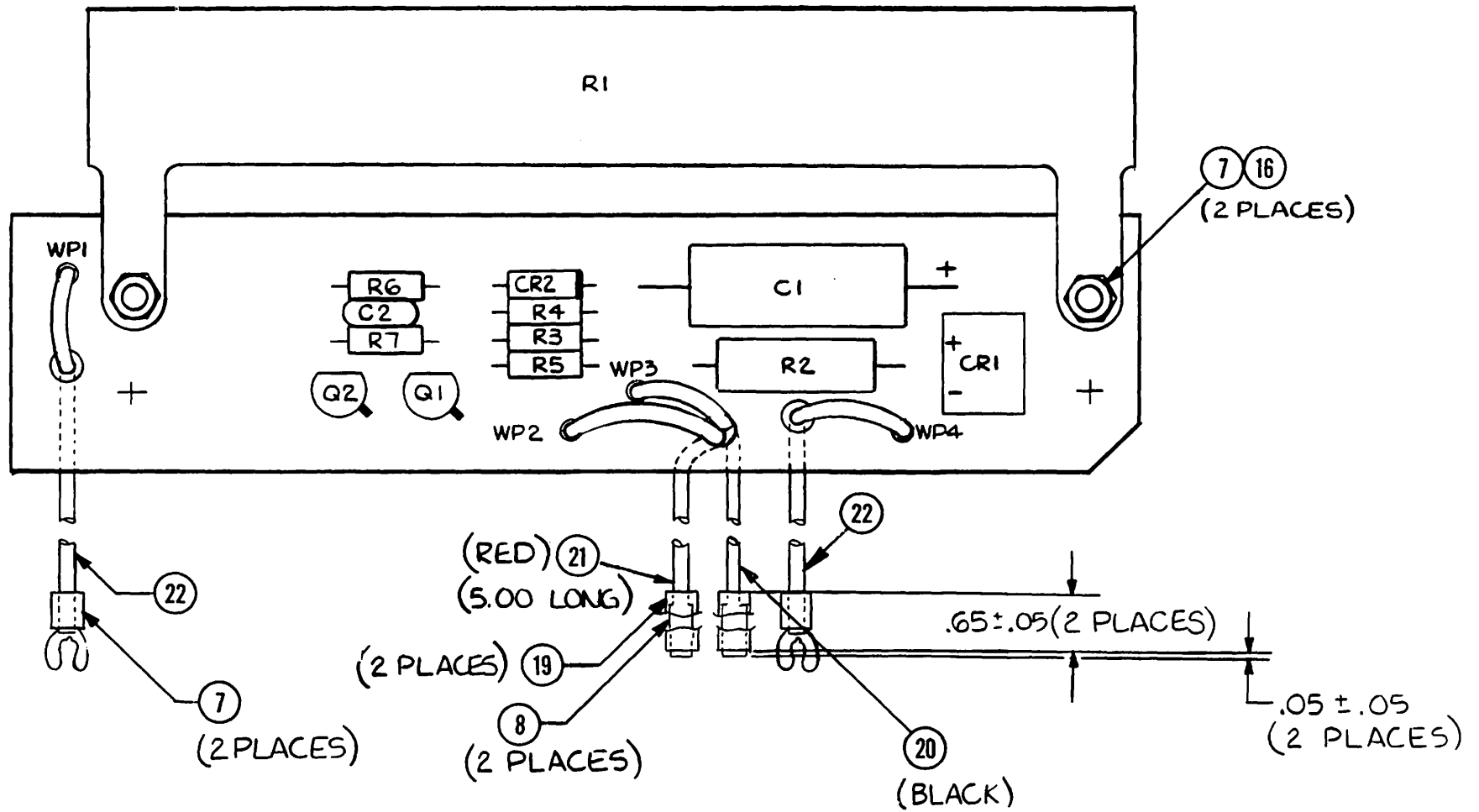

800167

Figure 5-18 Test Load PCB Assembly

## PARTS LIST

FIG AND ITEM No.	REF. DES.	PCC PART No.	DESCRIPTION	UNITS PER ASSY	USED ON CODE
5-18					
1		800167-00	ASSY, TEST LOAD PCB, DEFIB LP/6	REF	
2	C1	02-12648-00	CAPACITOR 50 $\mu$ f/50V	1	
3	C2	02-12048-00	CAPACITOR .01 $\mu$ f/500V	1	
4	CR1	02-14173-00	DIODE, BRIDGE, VM48	1	
5	CR2	200271-20	DIODE 1N3526, ZENER	1	
6		90-03021	KEPNUT 6-32 x 1/4	2	
7		90-06055	LUG #4-6 SPADE	2	
8		90-06077	RECEPTACLE, PIN	2	
9	R1	02-09632-00	RESISTOR WW, 50 OHM, 50W	1	
10	R2	200270-20	RESISTOR WW, .68 OHM, 5%, 2W	1	
11	R3	02-06055-00	RESISTOR CF, 300 OHM, 5%, 1/4W	1	
12	R4	02-06068-00	RESISTOR CF, 1K, 5%, 1/4W	1	
13	R5	02-06060-00	RESISTOR CF, 470 OHM, 5%, 1/4W	1	
14	R6	02-06058-00	RESISTOR CF, 390 OHM, 5%, 1/4W	1	
15	R7	02-06024-00	RESISTOR CF, 15 OHM, 5%, 1/4W	1	
16		90-01053	SCREW 6-32 x 1/4 BH	2	
17	Q1	02-14542-00	TRANSISTOR EN2484	1	
18	Q2	02-14606-00	TRANSISTOR PN2907A	1	
19		90-07002	TUBING, SHRINK, 1/8 BLK	A/R	
20		90-11052	WIRE, BLK, 22 AWG	A/R	
21		90-11055	WIRE, RED, 22 AWG	A/R	
22		200405-20	WIRE, HV, PVC JACKET, 80°C	A/R	

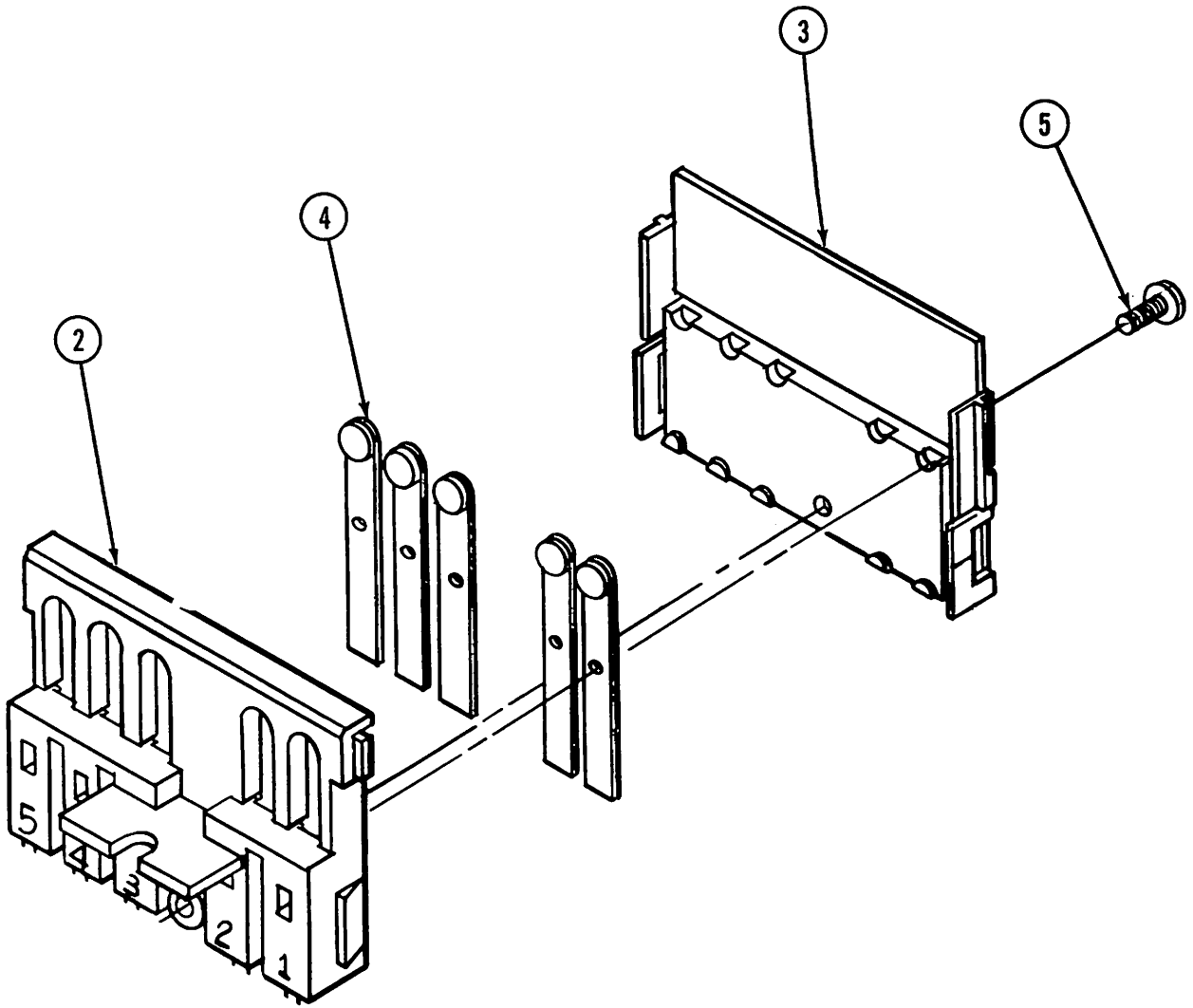

**800193**

Figure 5-19 Interconnect Assembly



## PARTS LIST

FIG AND ITEM No.	REF. DES.	PCC PART No.	DESCRIPTION	UNITS PER ASSY	USED ON CODE
5-19					
1		800193-02	INTERCONNECT ASSY DEFIB	REF	
2		800203-01	INSULATOR-INNER	1	
3		800204-00	INSULATOR-OUTER	1	
4		800365-02	CONTACT ASSY	5	
5		90-01165	SCREW, 4-40 x 1/4 PH, S, ST, CP	1	

SECTION VI  
SCHEMATICS

6-1 GENERAL

This section provides the engineering schematic drawings and applicable test point waveforms and/or voltages for the LIFEPAK 6 electronic cardiac care system. Table 6-1 lists the schematic drawings for the Cardioscope/Recorder module and the DC Defibrillator module.

TABLE 6-1  
SCHEMATIC DRAWINGS

DRAWING NO.*	NOMENCLATURE	FIGURE NO.
<b>CARDIOSCOPE RECORDER</b>		
800033	Recorder PCB Schematic	6-1
800101	Preamplifier PCB Schematic	6-2
800157	Monitor Charger PCB Schematic	6-3
800159	No-Fade PCB Schematic	6-4
800161	Display PCB Schematic	6-5
800112	Power Supply PCB Schematic	6-6
800053	Rate PCB Schematic	6-7
800270	Interconnect Diagram	6-8
800151	Main Flex Cable Schematic	6-9
800170	Control Flex Cable Schematic	6-10
<b>DC DEFIBRILLATOR</b>		
800041	Charger PCB Schematic	6-11
800163	Main PCB Schematic	6-12
800167	Test Load PCB Schematic	6-13
800260	Interconnect Diagram	6-14
800165	Control Panel Flex Cable Schematic	6-15

\*Check change information section at the rear of the manual.

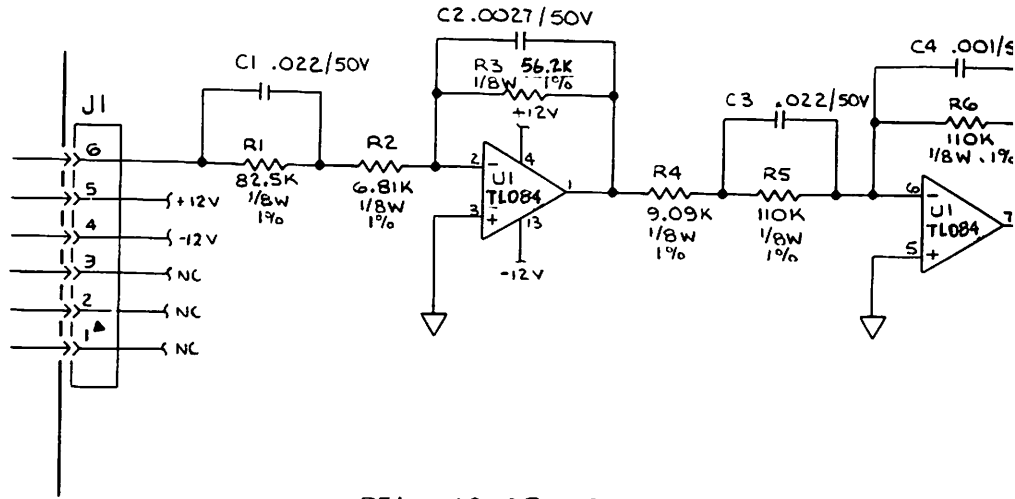

PEN MOTOR DRIVE CIRCUITRY

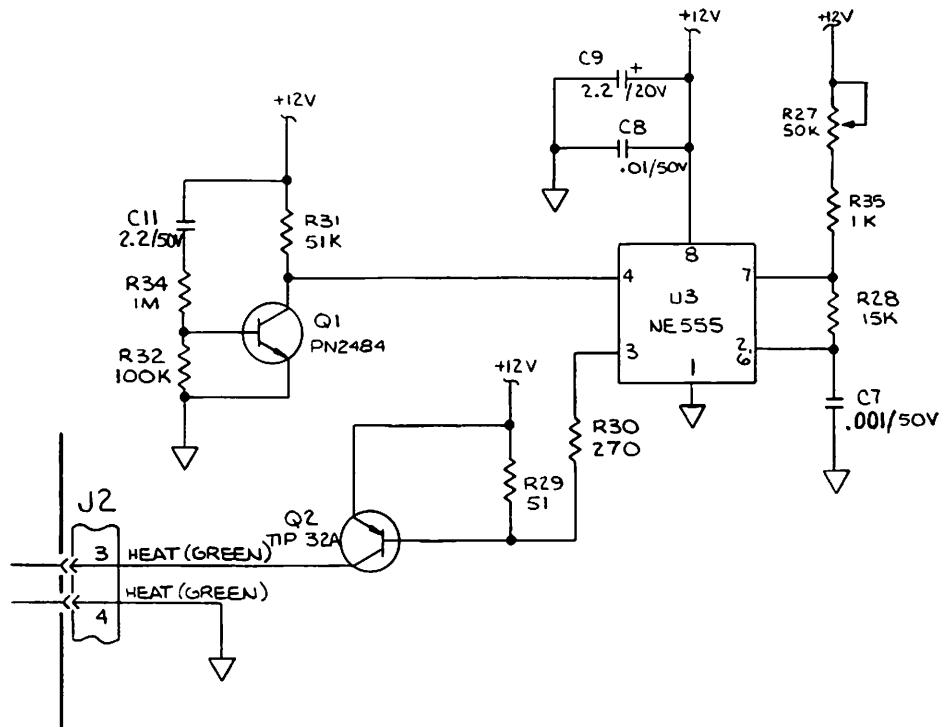

STYLUS HEAT CIRCUITRY

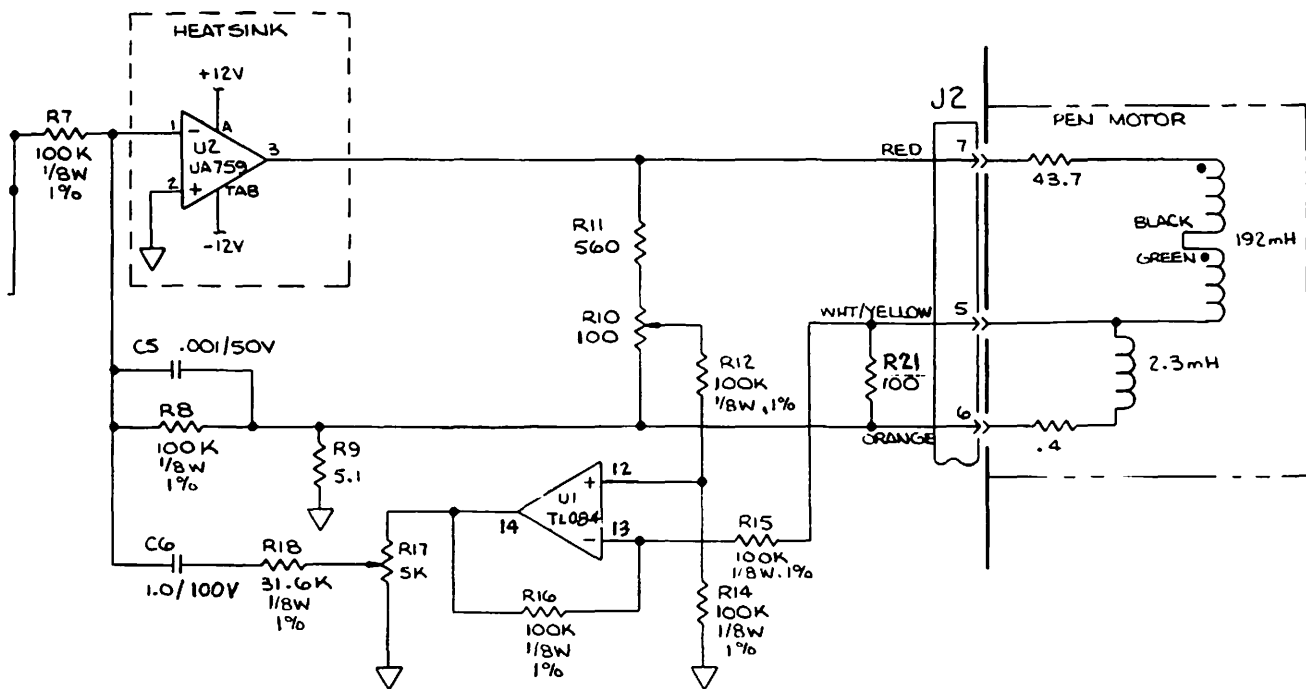

NOTES: UNLESS OTHERWISE SPECIFIED

1. ALL RESISTORS ARE IN OHMS, 1/4W, 5%.
2. ALL CAPACITORS IN MFD/WVDC.

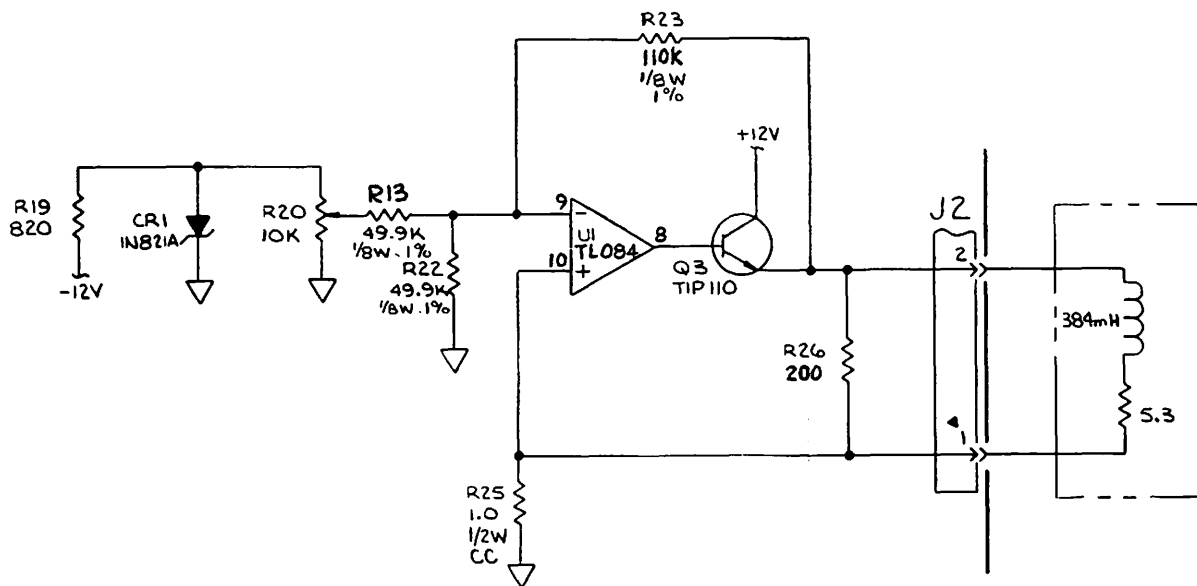

800033

PAPER MOTOR DRIVE CIRCUITRY

Figure 6-1 Recorder PCB Schematic

6-3

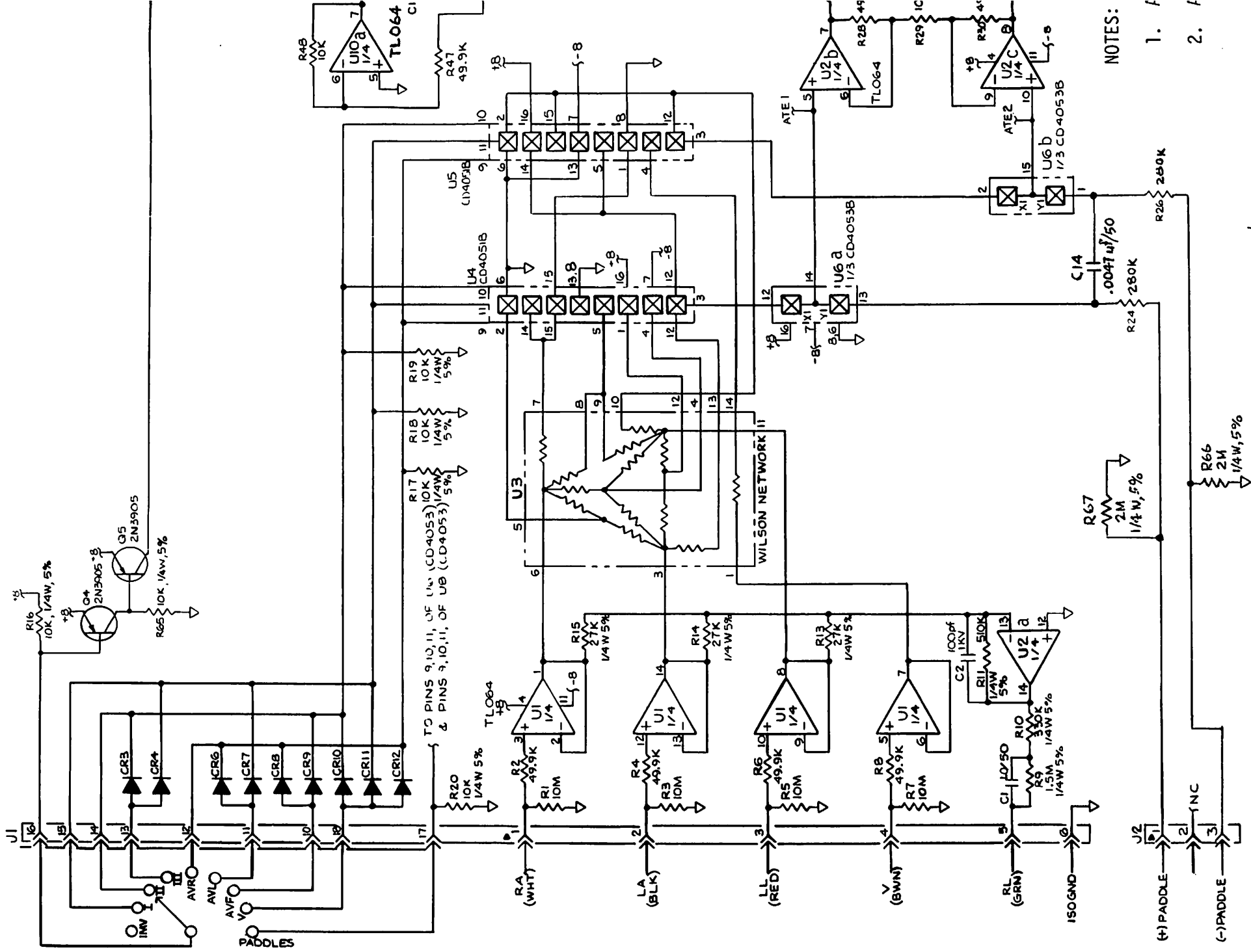

- NOTES:
1. F
  2. F

6-4

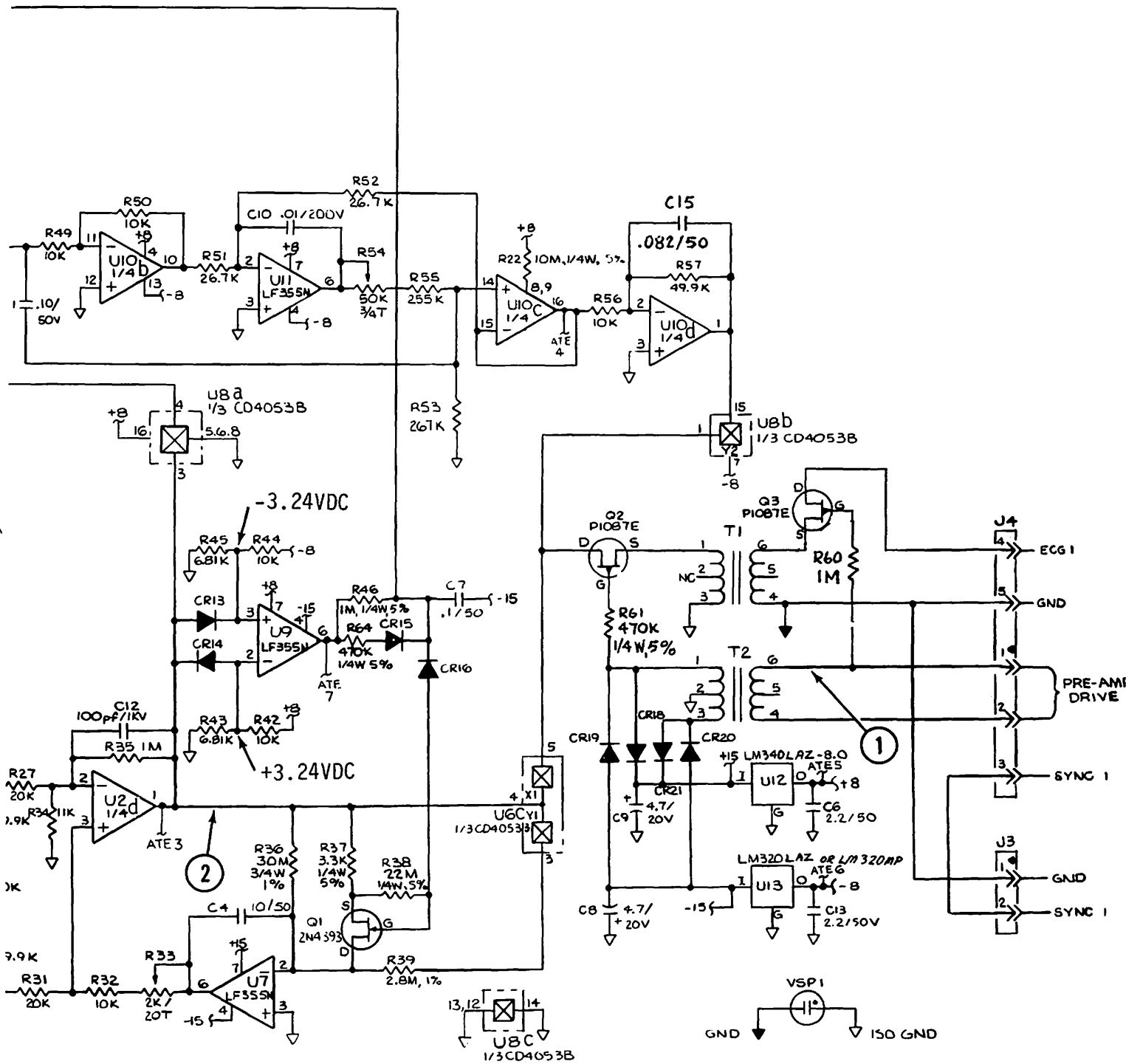

UNLESS OTHERWISE SPECIFIED

ALL RESISTORS ARE IN OHMS, 1/8W, 1%.

ALL CAPACITORS IN MFD/WVDC.

800101

Figure 6-2 Preamplifier PCB Schematic (Sheet 1 of 2)

6-5

6-4/6-5

Jan. 19

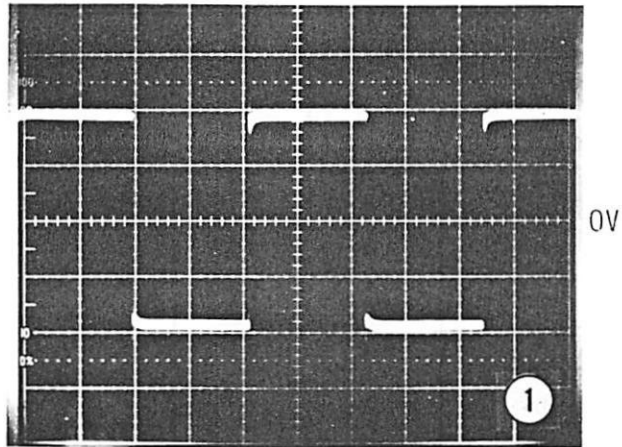

Vertical: 10V/DIV  
Horizontal: 10ms/DIV

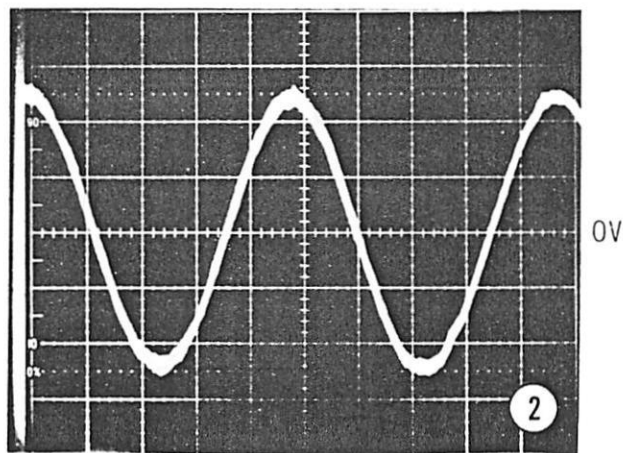

Vertical: .1V/DIV  
Horizontal: 20ms/DIV

Figure 6-2. Preamplifier Test Point Waveforms  
(Sheet 2 of 2)





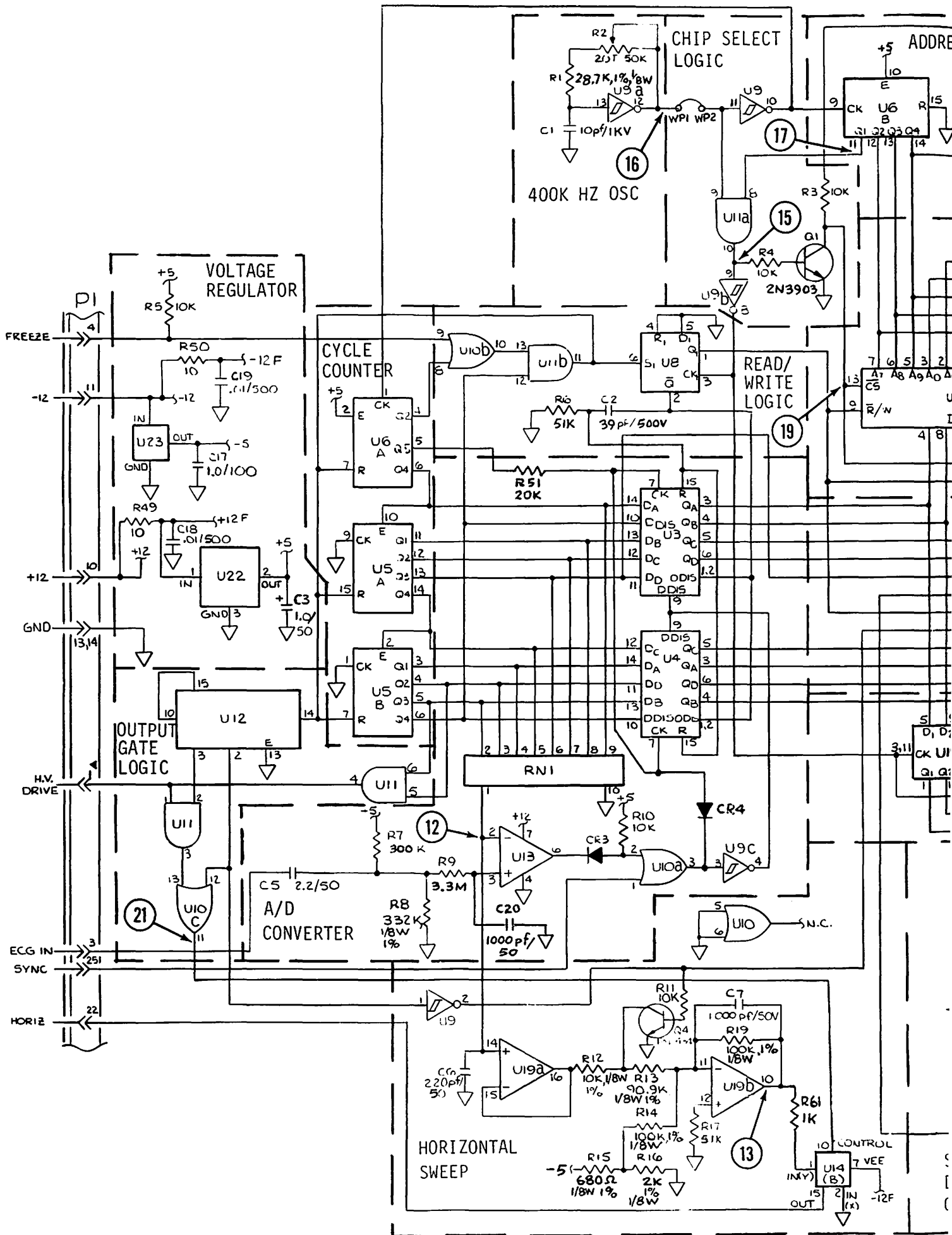

DES	TYPE	GND	+5
U1,U2	4104A	11	10
U3,U4	4076B	8	16
U5	MC14520	8	16
U6	"	8	16
U7	"	8	16
U8	4013	7	14
U9	74C14	7	14
U10	4071B	7	14
U11	4081B	7	14
U12	4017	8	16
U13	CA 3130	—	—
U14	4053B	6,B	16
U15,U18	4013	7	14
U16,U17	MC14174	8	16
U19,U20	TL084	—	—
U21	4068	7	14
U22	LM340LA5	—	—
U23	LM320VP-5	—	—

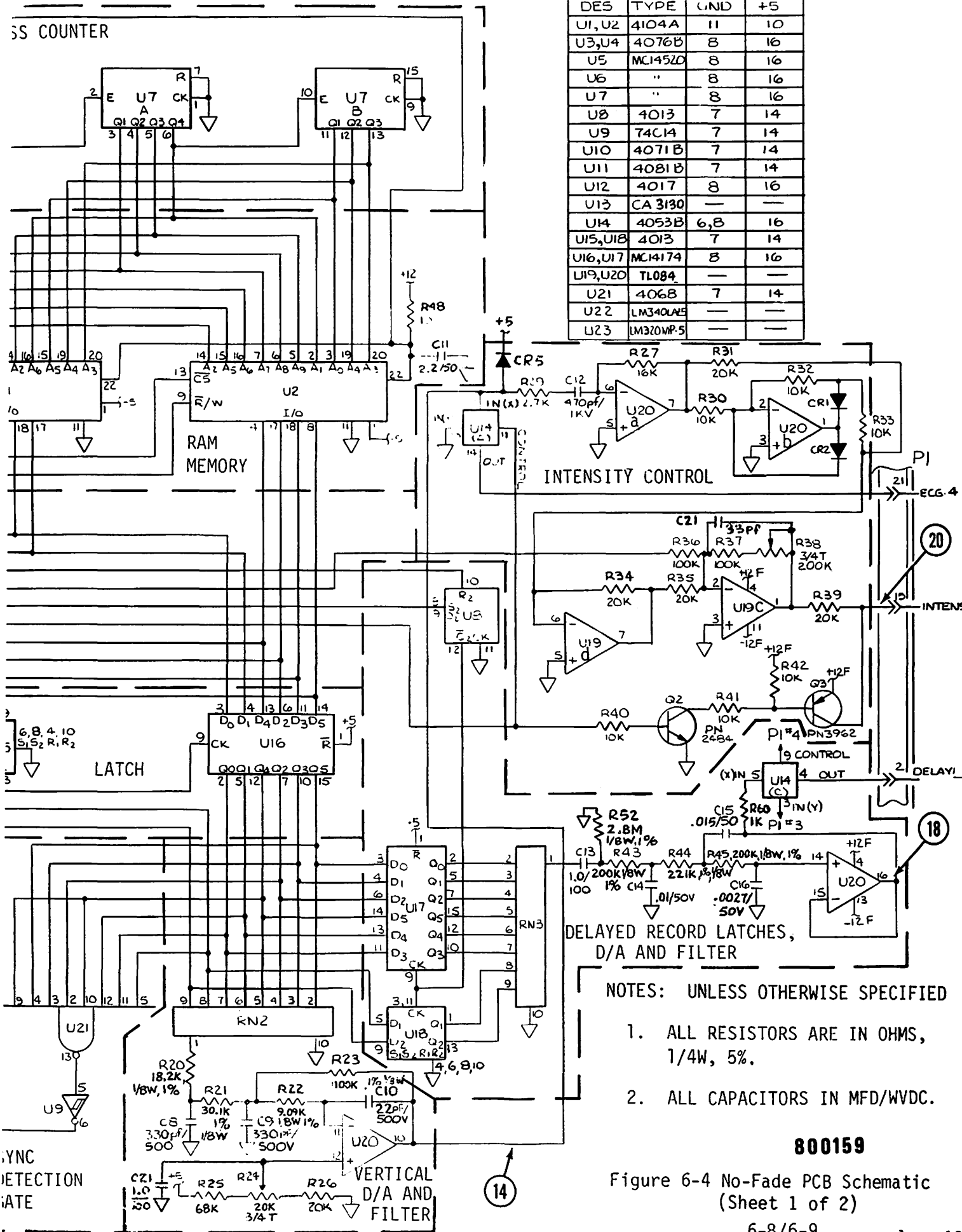

NOTES: UNLESS OTHERWISE SPECIFIED

1. ALL RESISTORS ARE IN OHMS, 1/4W, 5%.
2. ALL CAPACITORS IN MFD/WVDC.

**800159**

Figure 6-4 No-Fade PCB Schematic (Sheet 1 of 2)

6-8/6-9

Jan. 19

69

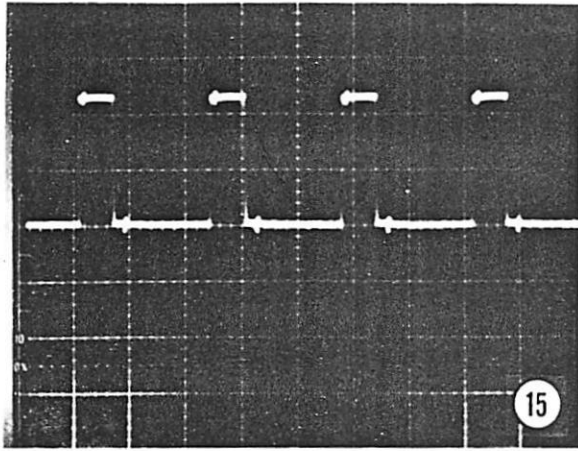

Vertical: 2V/DIV  
Horizontal: 2ms/DIV

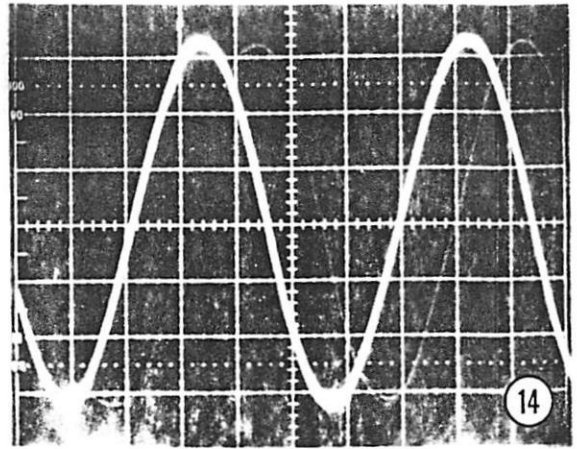

.5V/DIV  
20ms/DIV

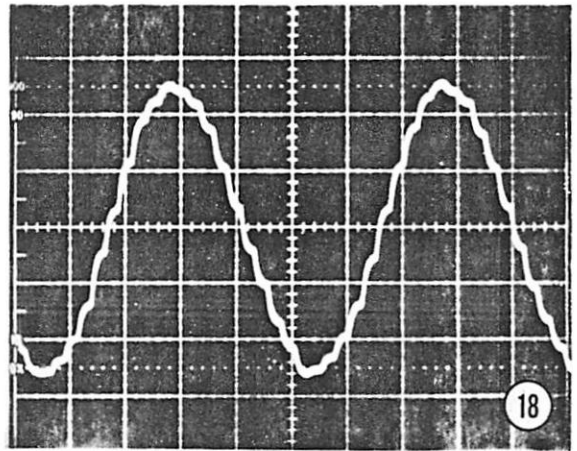

Vertical: .5V/DIV  
Horizontal: 20ms/DIV

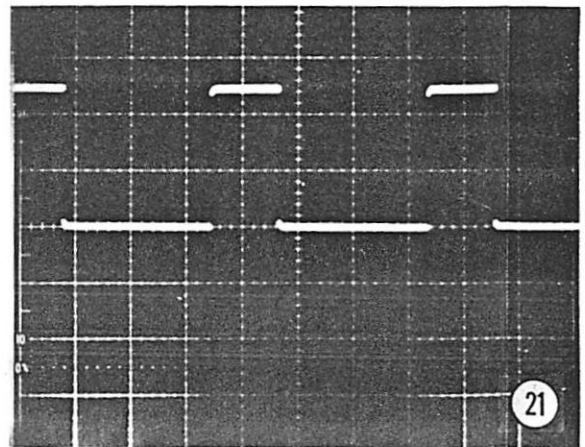

Vertical: 2V/DIV  
Horizontal: 5ms/DIV

6-10



14

1V/DIV  
1V/DIV

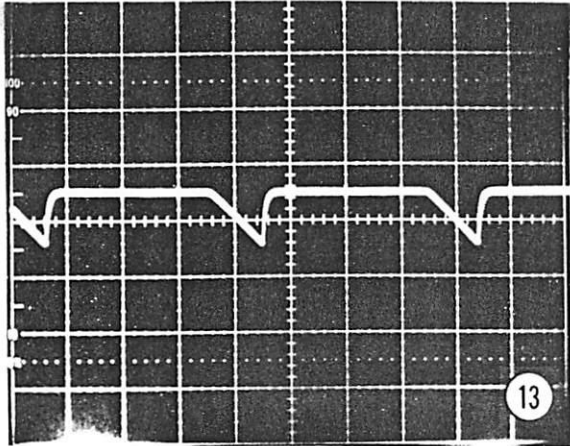

13

5V/DIV  
5ms/DIV

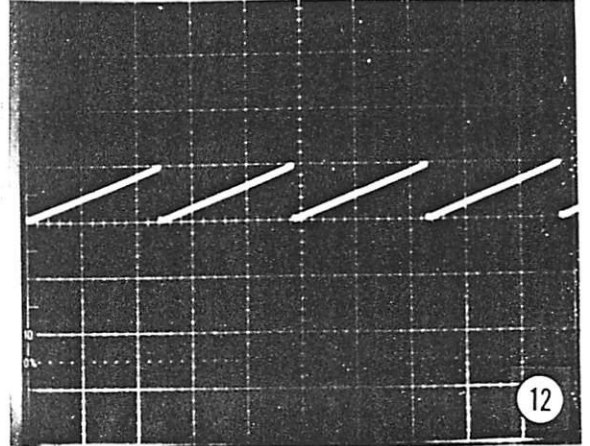

12

5V/DIV  
2ms/DIV



18

1V/DIV  
1V/DIV

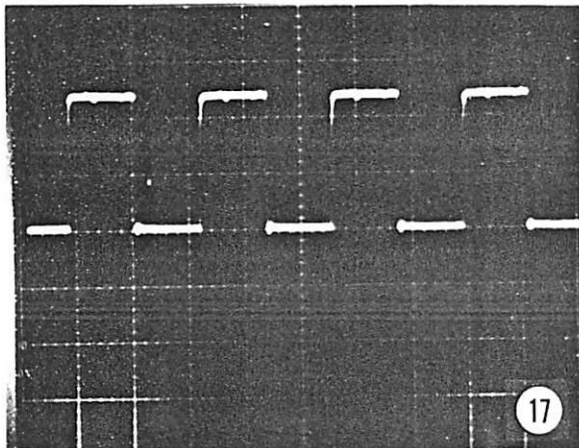

17

2V/DIV  
2ms/DIV

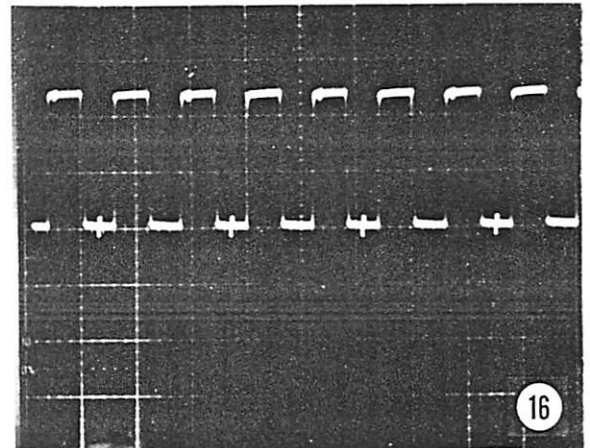

16

2V/DIV  
2ms/DIV



21

1V/DIV  
1V/DIV

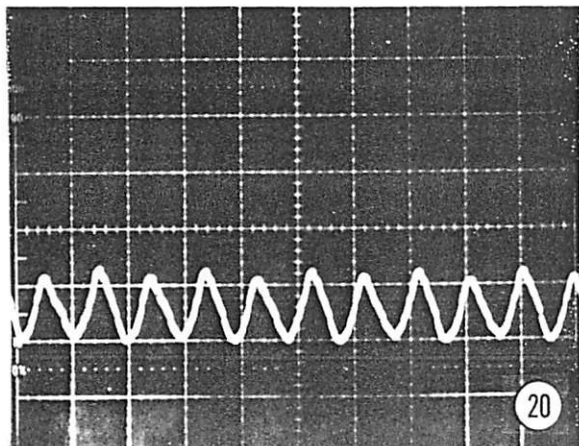

20

5V/DIV  
50ms/DIV

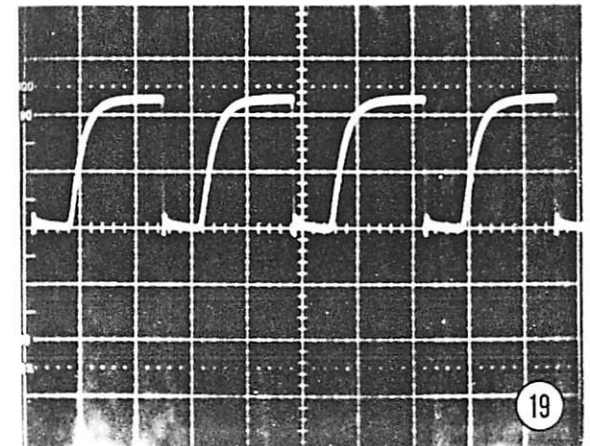

19

5V/DIV  
2ms/DIV

6-11

Figure 6-4. No Fade Board Test Point Waveforms (Sheet 2 of 2)

6-10/6-11

Jan.

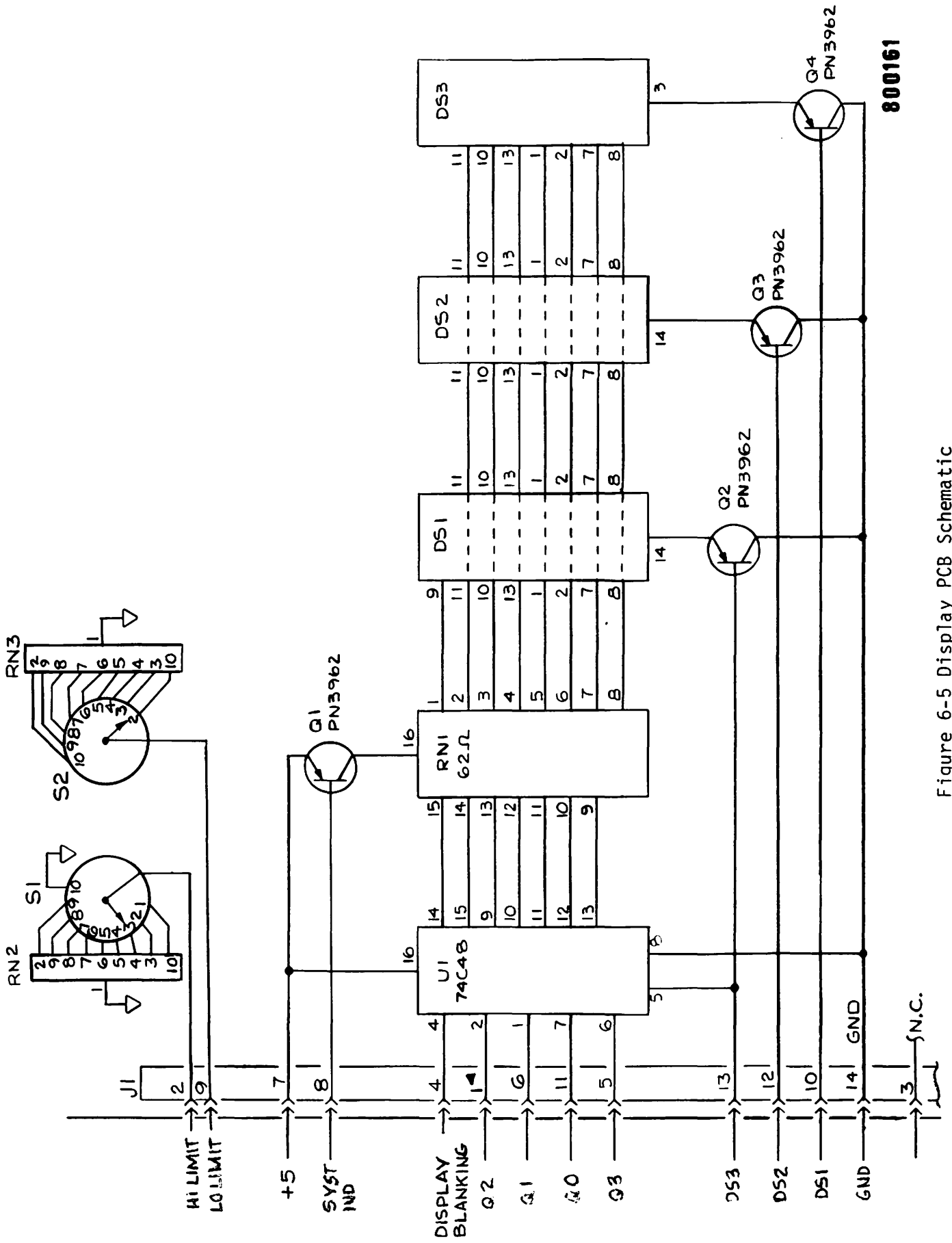

800161

Figure 6-5 Display PCB Schematic

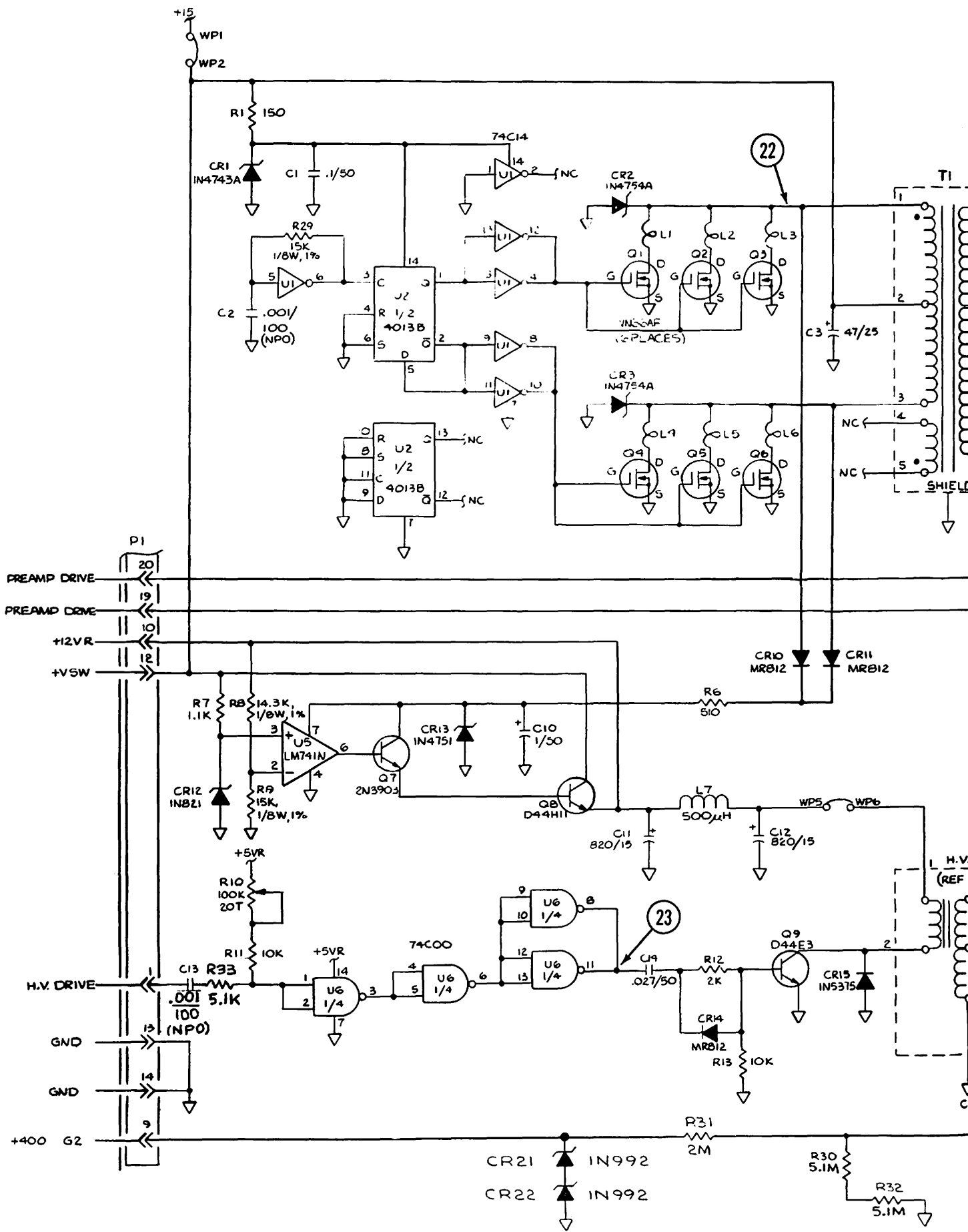

6-13

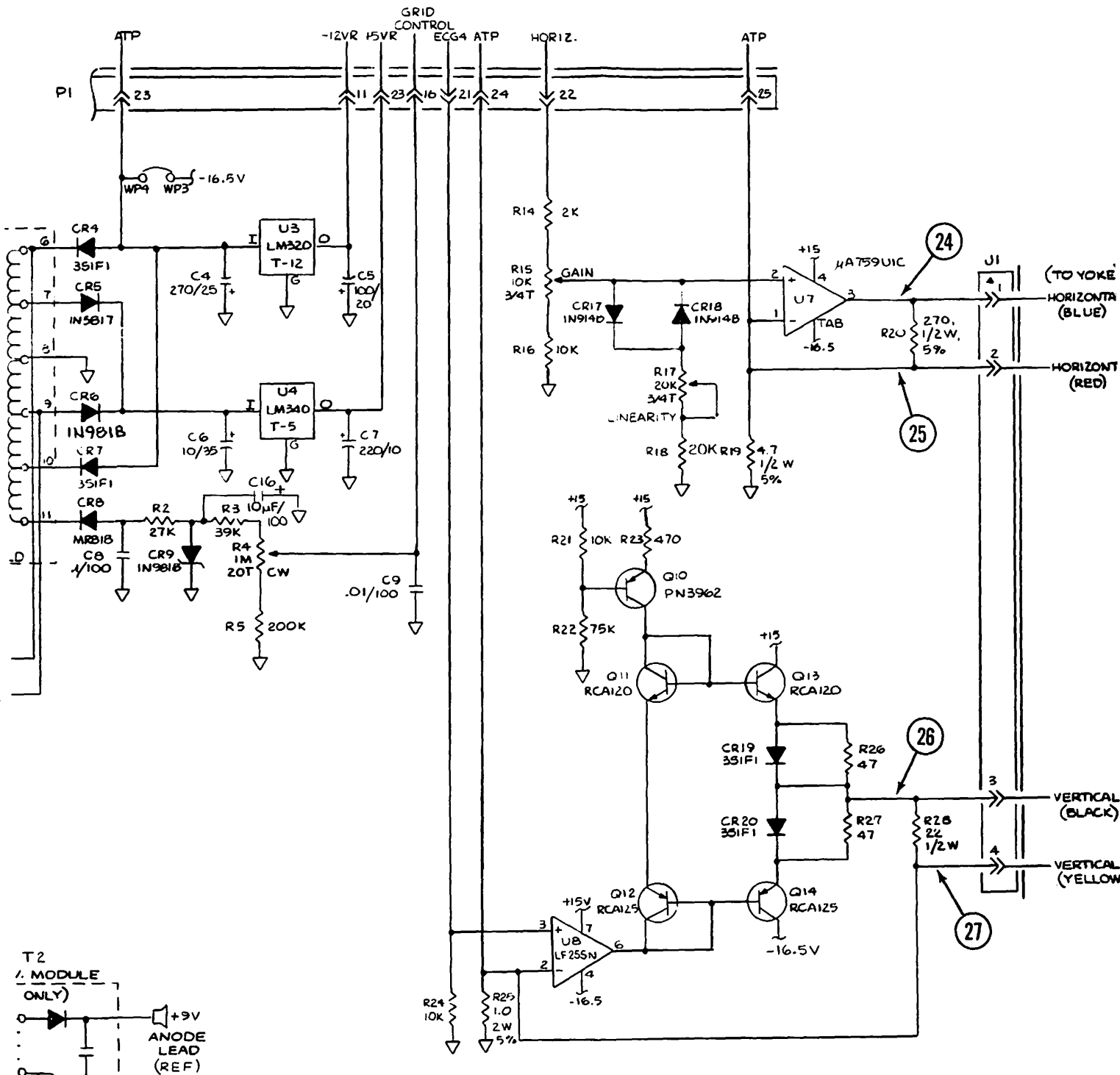

800112

- NOTES: UNLESS OTHERWISE SPECIFIED
1. ALL RESISTORS ARE IN OHMS, 1/4W, 5%.
  2. ALL CAPACITORS IN MFD/WVDC.

Figure 6-6 Power Supply PCB Schematic (Sheet 1 of 2)

6-13/6-14

Jan 19

b-14



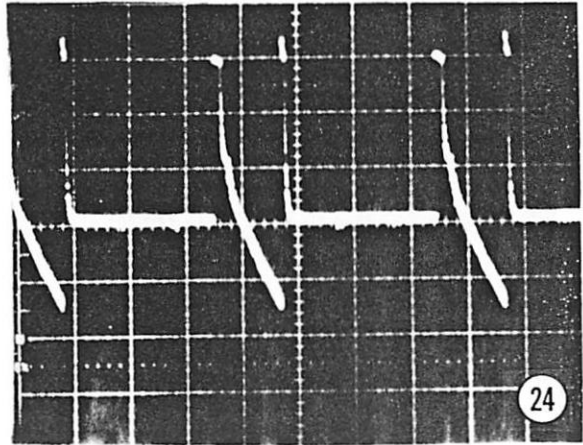

Vertical: 5V/DIV  
Horizontal: 5ms/DIV

24

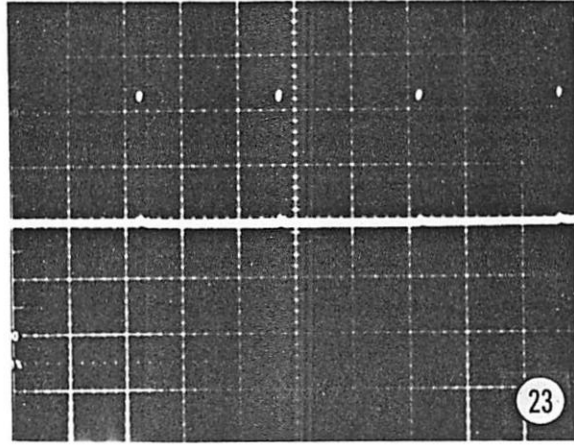

2V/DIV  
2ms/DIV

23

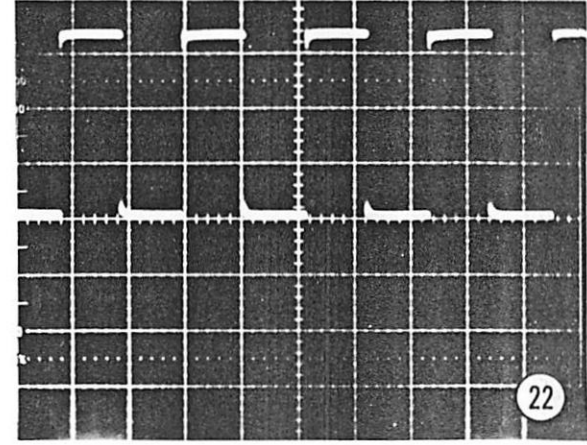

10V/DIV  
20ms/DIV

22

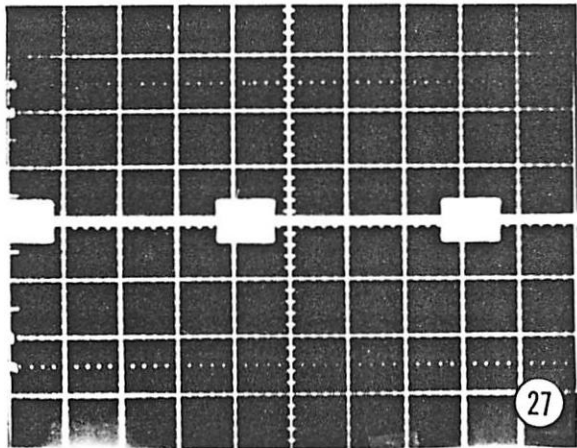

Vertical: 5V/DIV  
Horizontal: 5ms/DIV

27

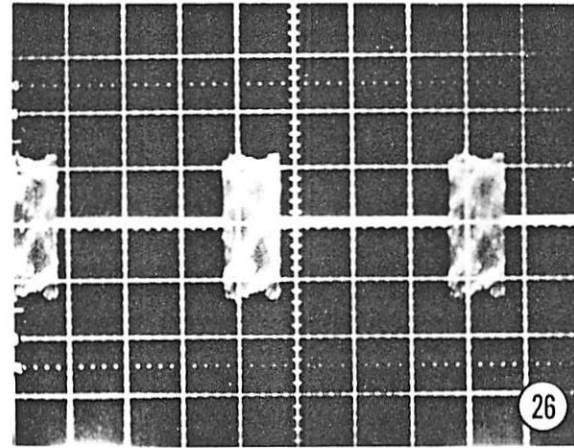

5V/DIV  
5ms/DIV

26

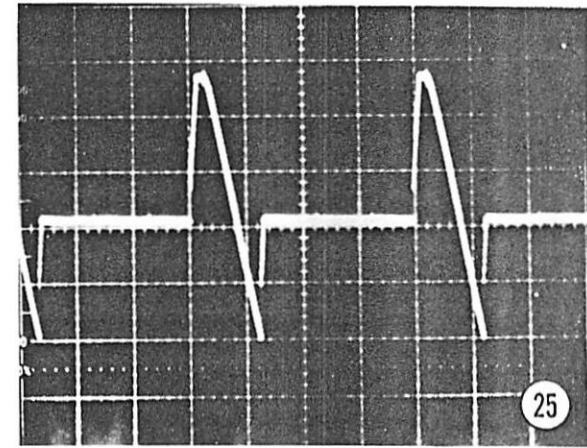

.5V/DIV  
5ms/DIV

25

6-15

Jan. 1979

Figure 6-6. Power Supply Board Test Point Waveforms  
(Sheet 2 of 2)



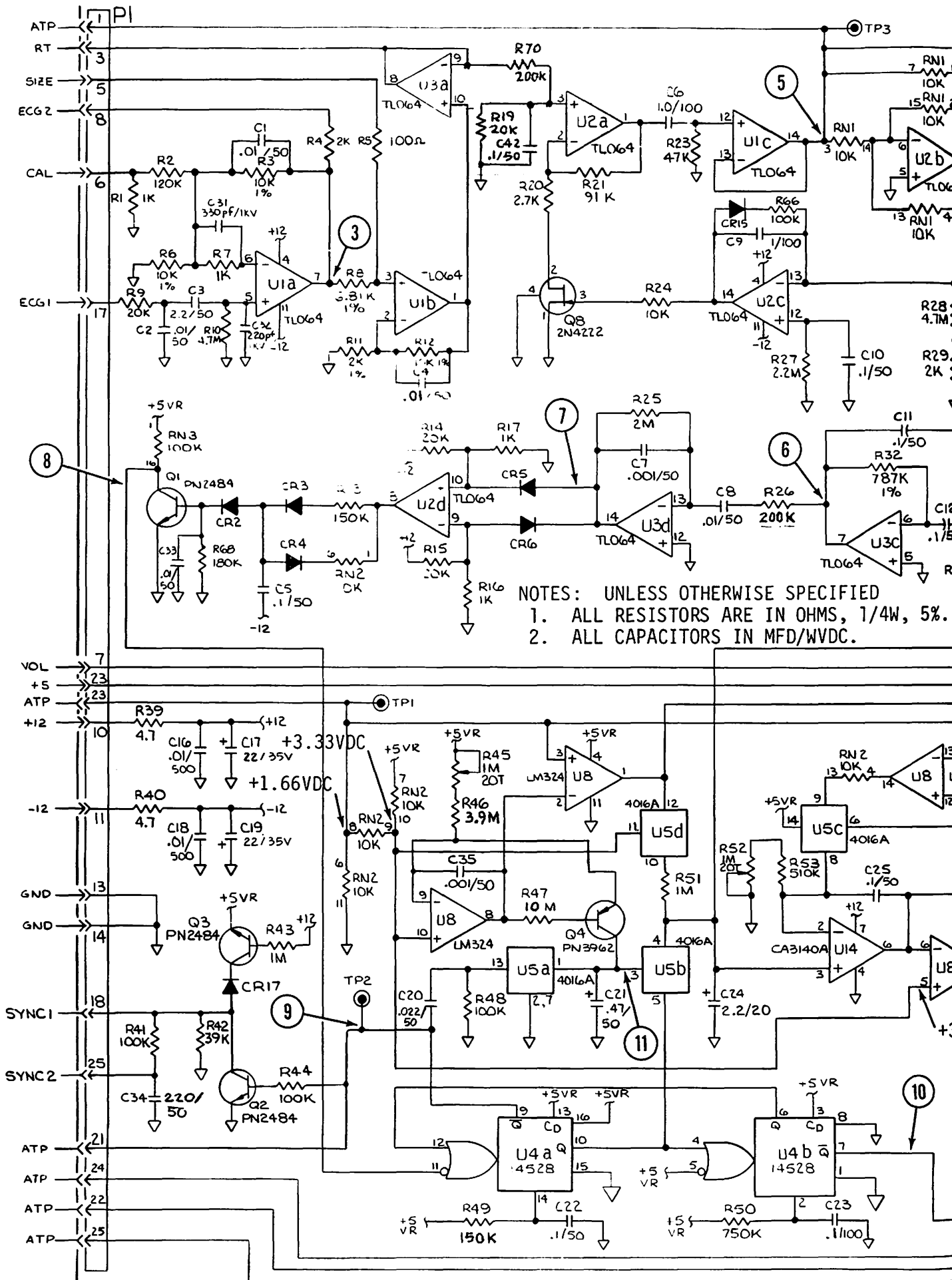

NOTES: UNLESS OTHERWISE SPECIFIED  
 1. ALL RESISTORS ARE IN OHMS, 1/4W, 5%.  
 2. ALL CAPACITORS IN MFD/WVDC.

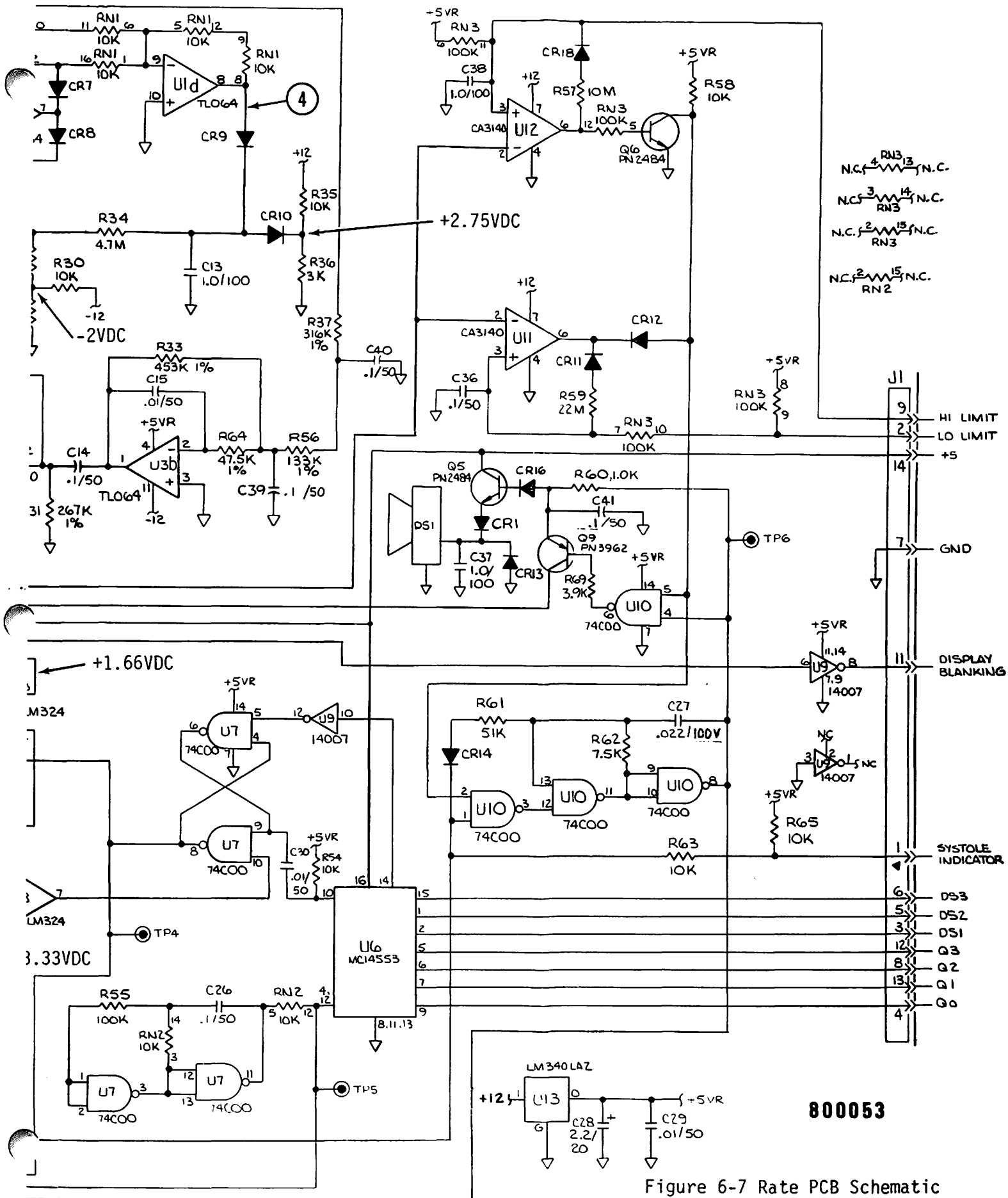
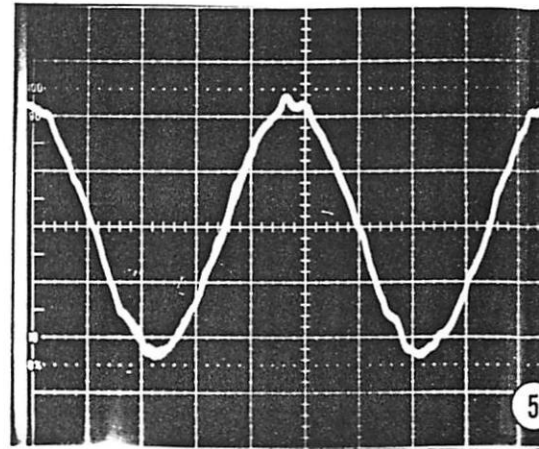

Figure 6-7 Rate PCB Schematic  
(Sheet 1 of 2)

800053

6-17

6-16/6-17 Jan 1979



Vertical: 1V/DIV  
Horizontal: 20ms/D

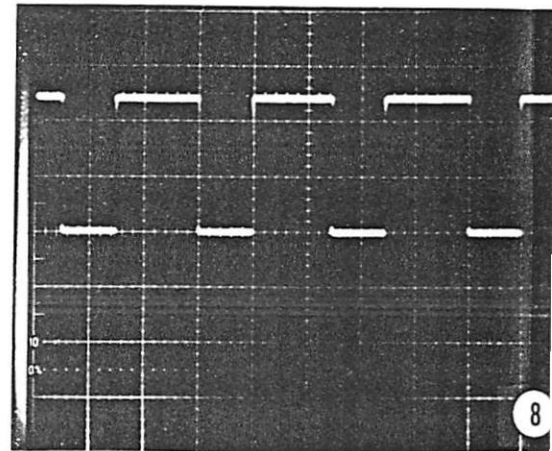

Vertical: 2V/DIV  
Horizontal: 10ms/D

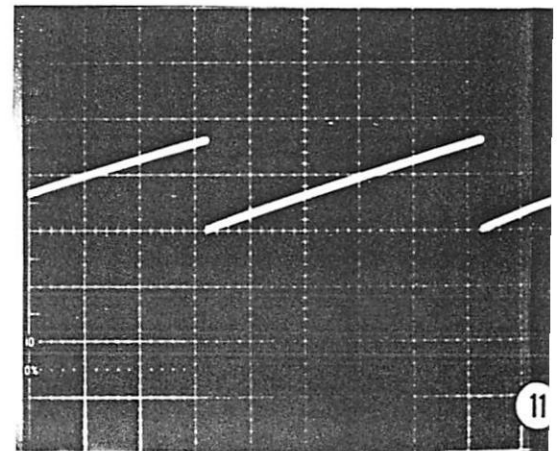

60BPM  
Vertical: .5/DIV  
Horizontal: .25/D

6-18



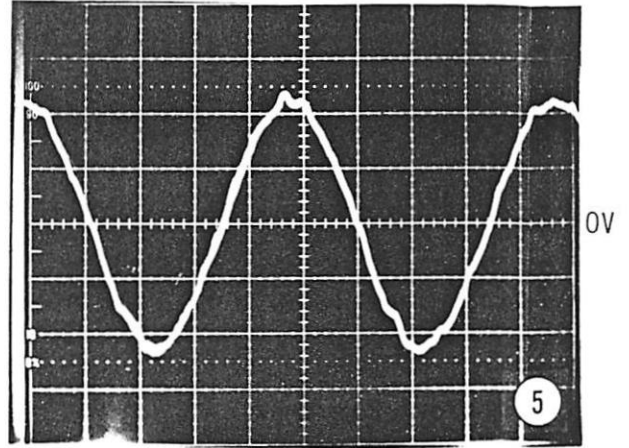

Vertical: 1V/DIV  
Horizontal: 20ms/DIV

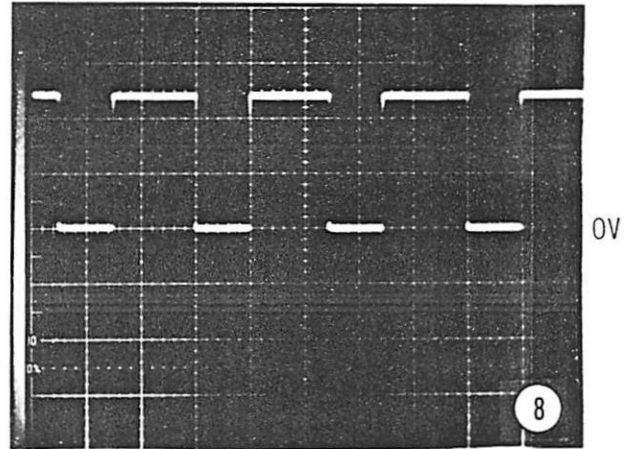

Vertical: 2V/DIV  
Horizontal: 10ms/DIV

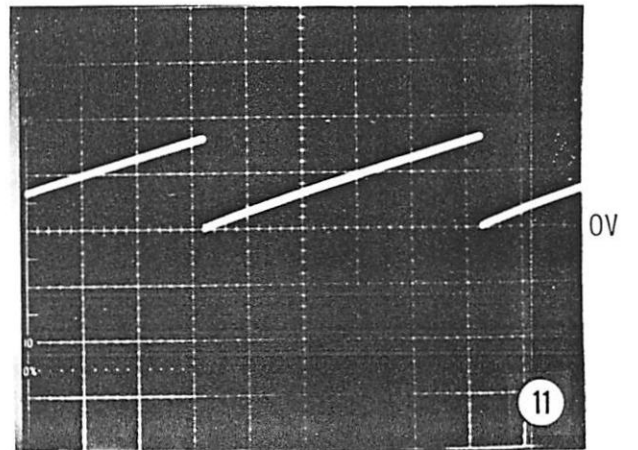

60BPM  
Vertical: .5/DIV  
Horizontal: .25/DIV

6-18

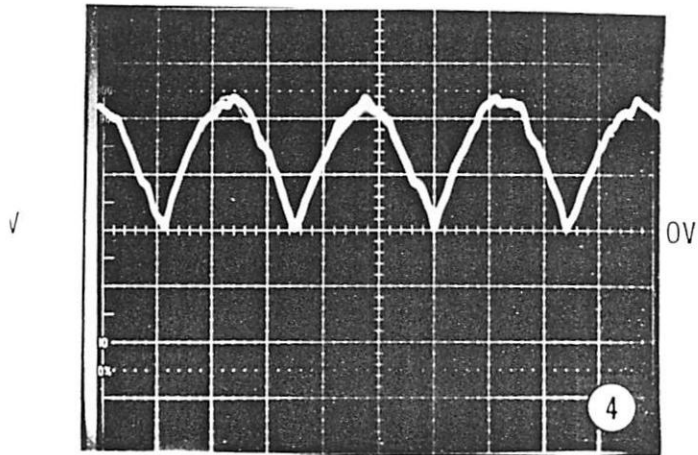

1V/DIV  
20ms/DIV

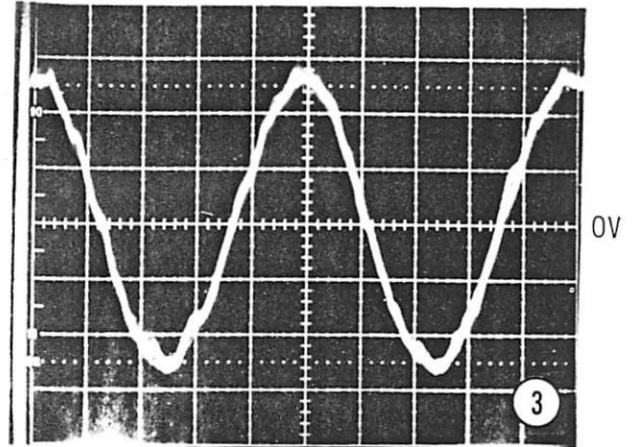

.2V/DIV  
20ms/DIV

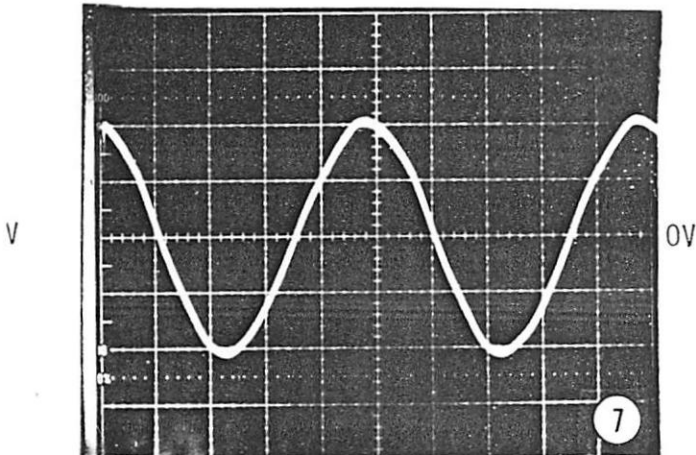

1V/DIV  
20ms/DIV

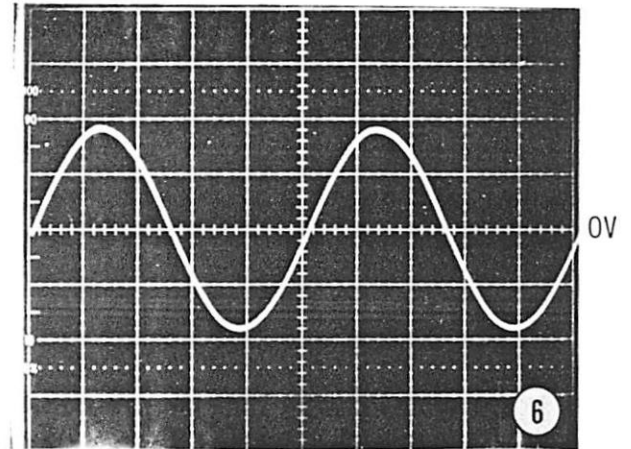

1V/DIV  
20ms/DIV

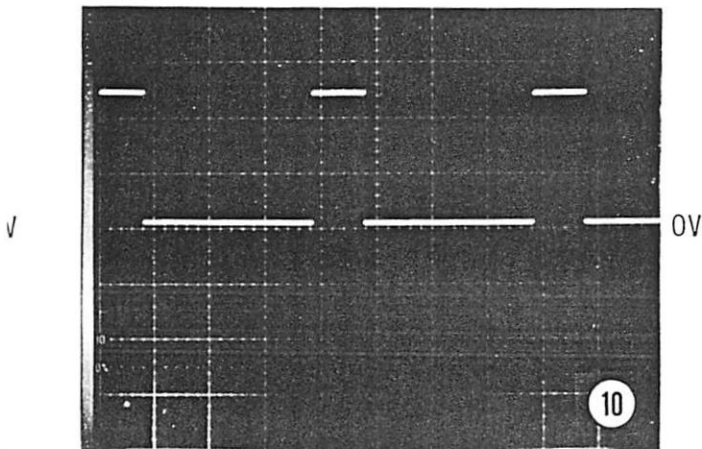

2V/DIV  
50ms/DIV

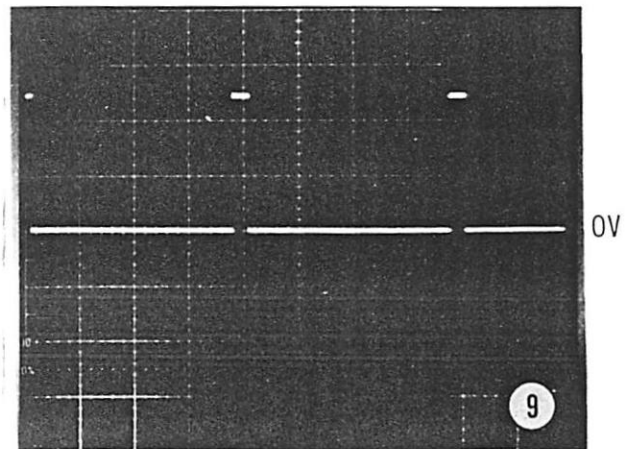

2V/DIV  
50ms/DIV

Figure 6-7. RATE BOARD TEST POINT WAVEFORMS  
(Sheet 2 of 2)  
6-18/6-19

6-19

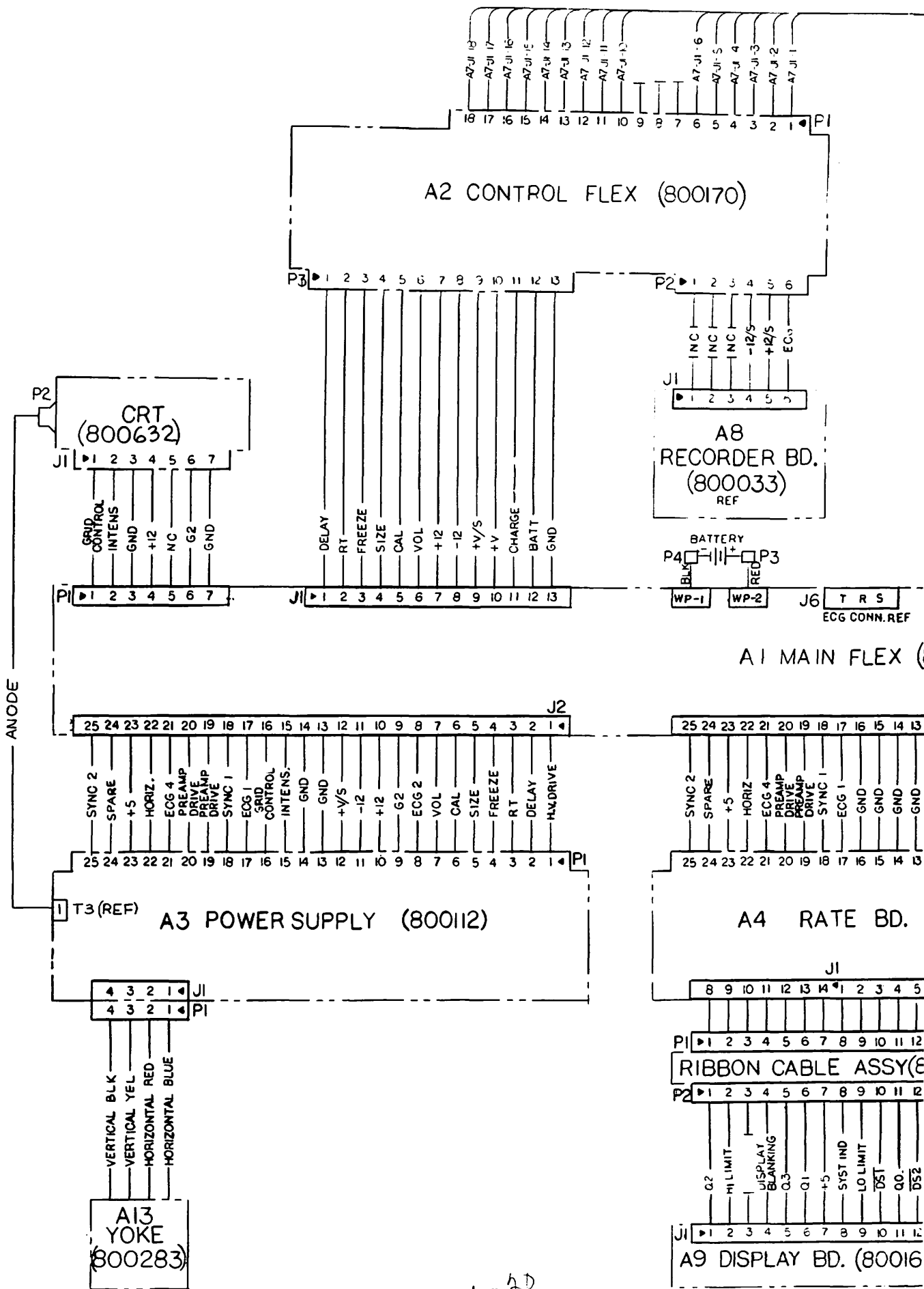

6-2D



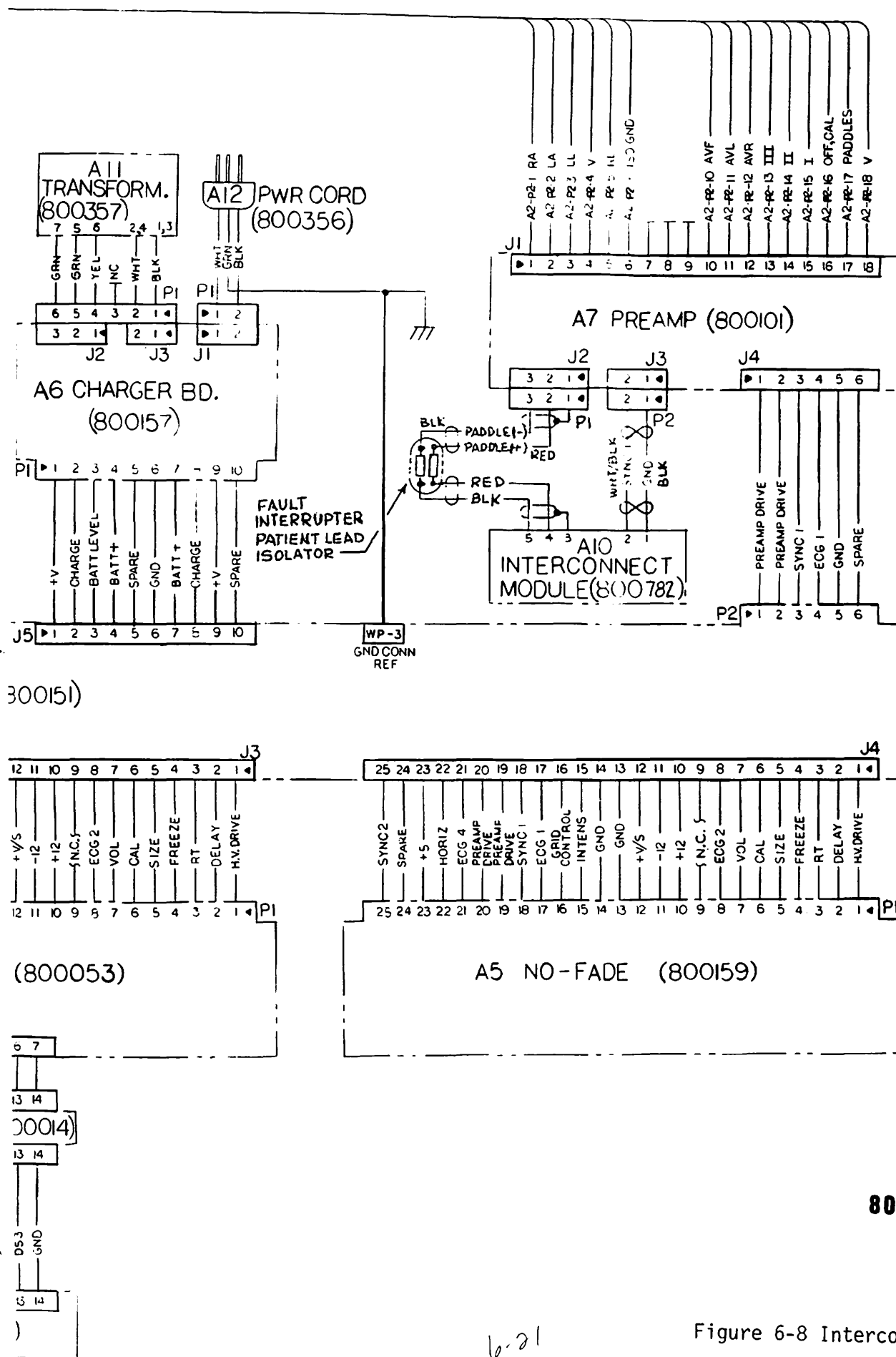

300151)

800270

Figure 6-8 Interconnect Diagram

6-20/6-21

Jan 1

6-21



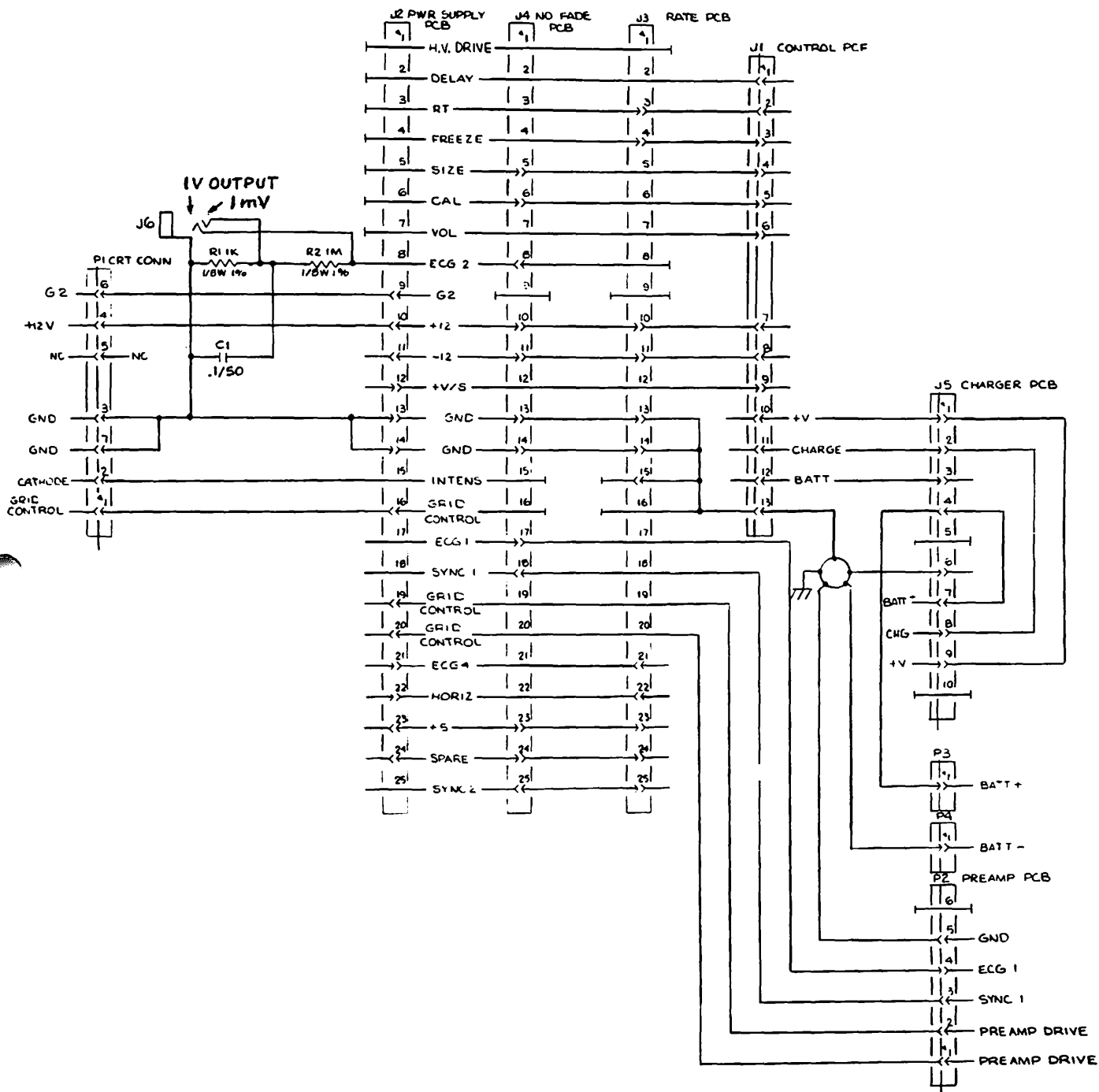

800151

Figure 6-9 Main Flex Cable Schematic

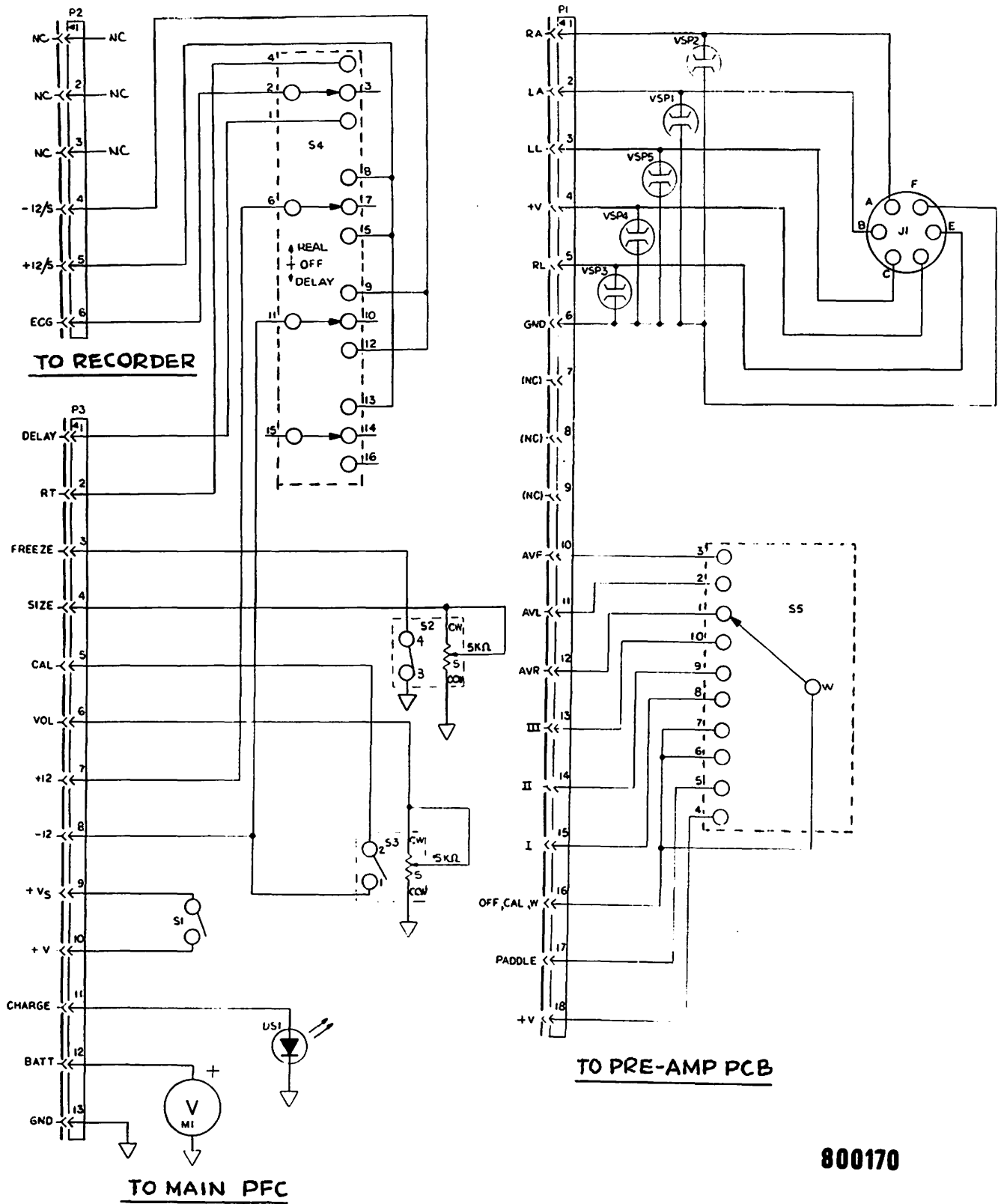
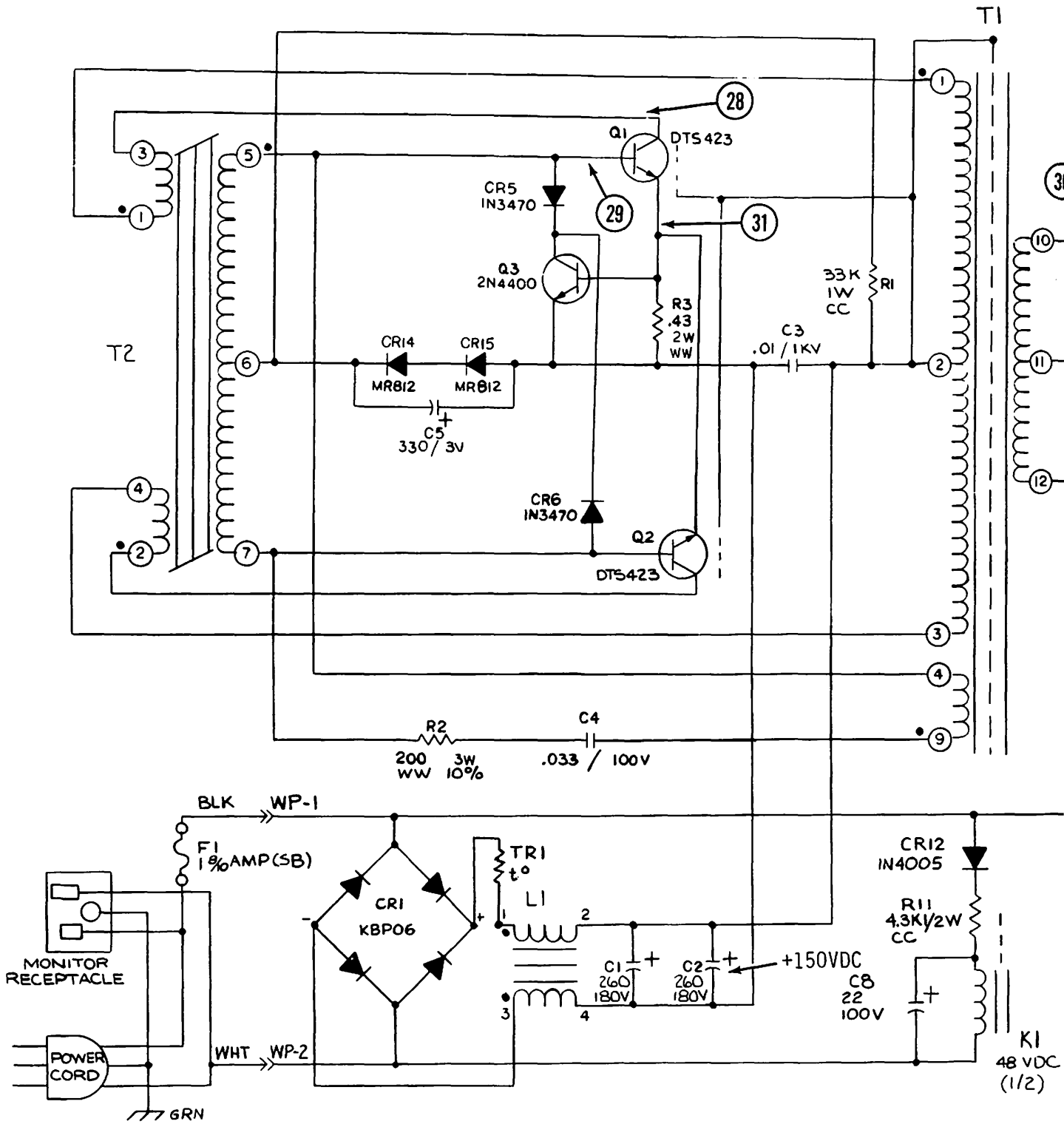
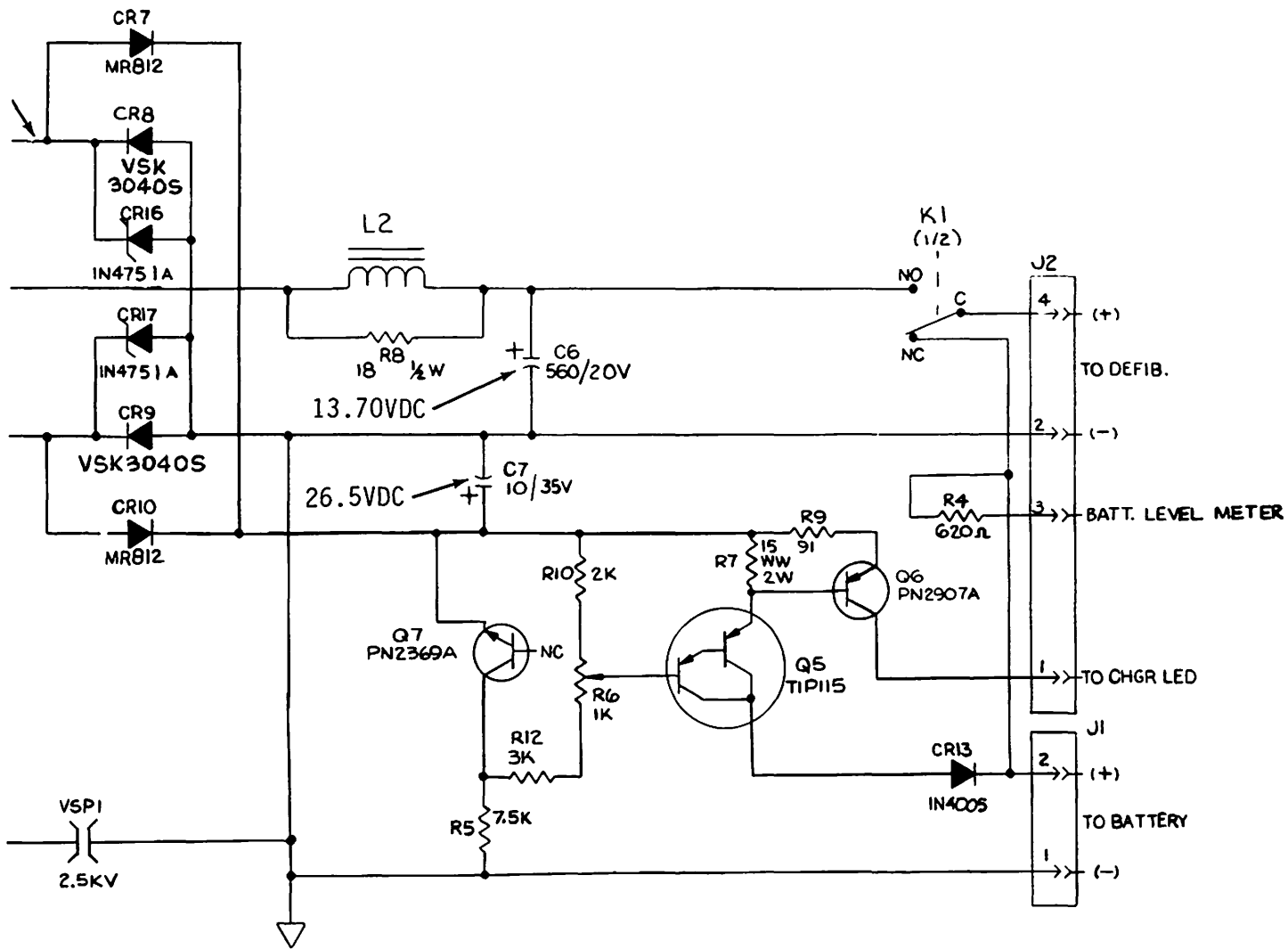

Figure 6-10 Control Flex Cable Schematic

800170



6-24



NOTES: UNLESS OTHERWISE SPECIFIED  
 1. ALL RESISTORS ARE IN OHMS, 1/4W, 5%.  
 2. ALL CAPACITORS IN MFD/WVDC.

800041

10-25

Figure 6-11 Charger PCB Schematic  
 (Sheet 1 of 2)

6-24/6-25

Jan 19

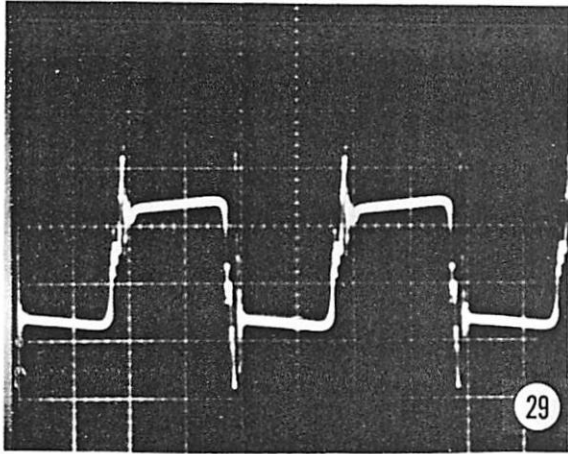

Vertical: 2V/DIV  
Horizontal: 10ms/DIV

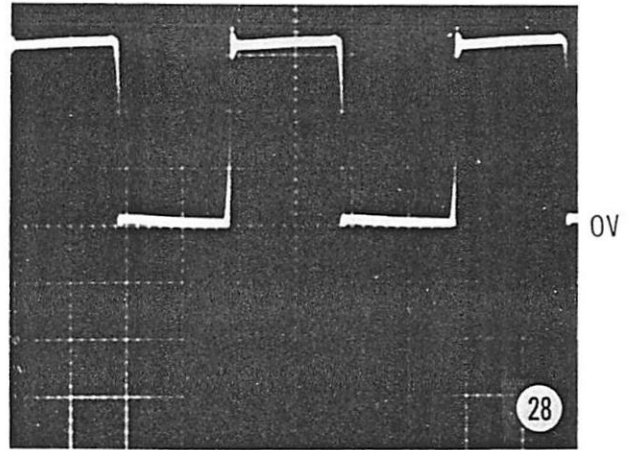

100V/DIV  
10ms/DIV

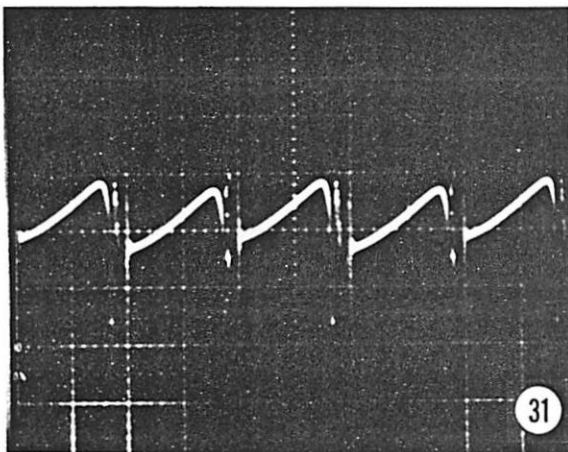

Vertical: .2V/DIV  
Horizontal: 10ms/DIV

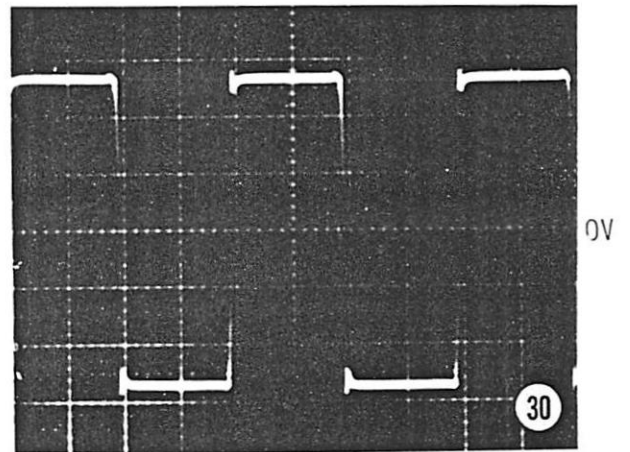

10V/DIV  
10ms/DIV

Figure 6-11. Charger Board Test Point Waveforms  
(Sheet 2 of 2)

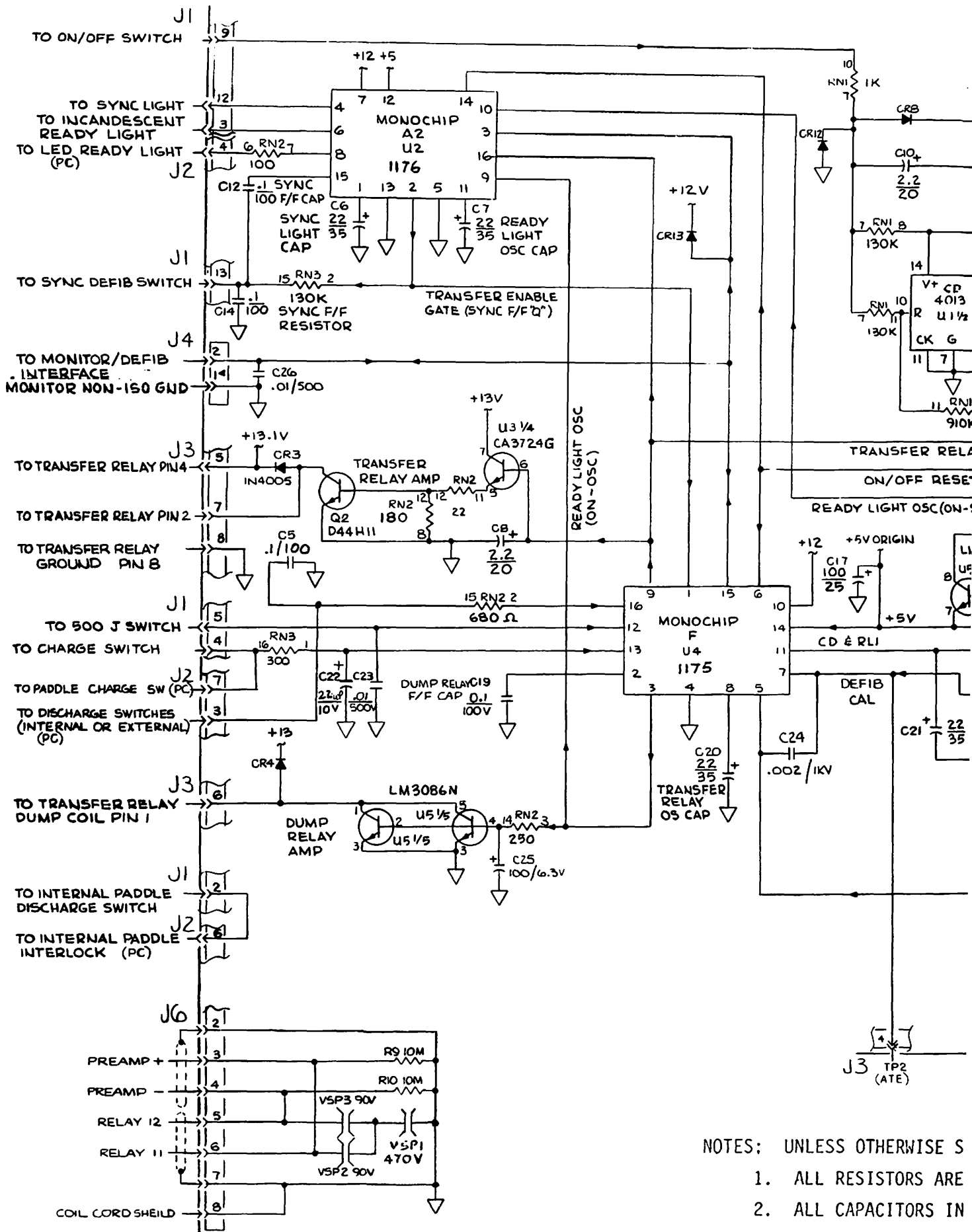

- NOTES: UNLESS OTHERWISE S
1. ALL RESISTORS ARE
  2. ALL CAPACITORS IN

6.27

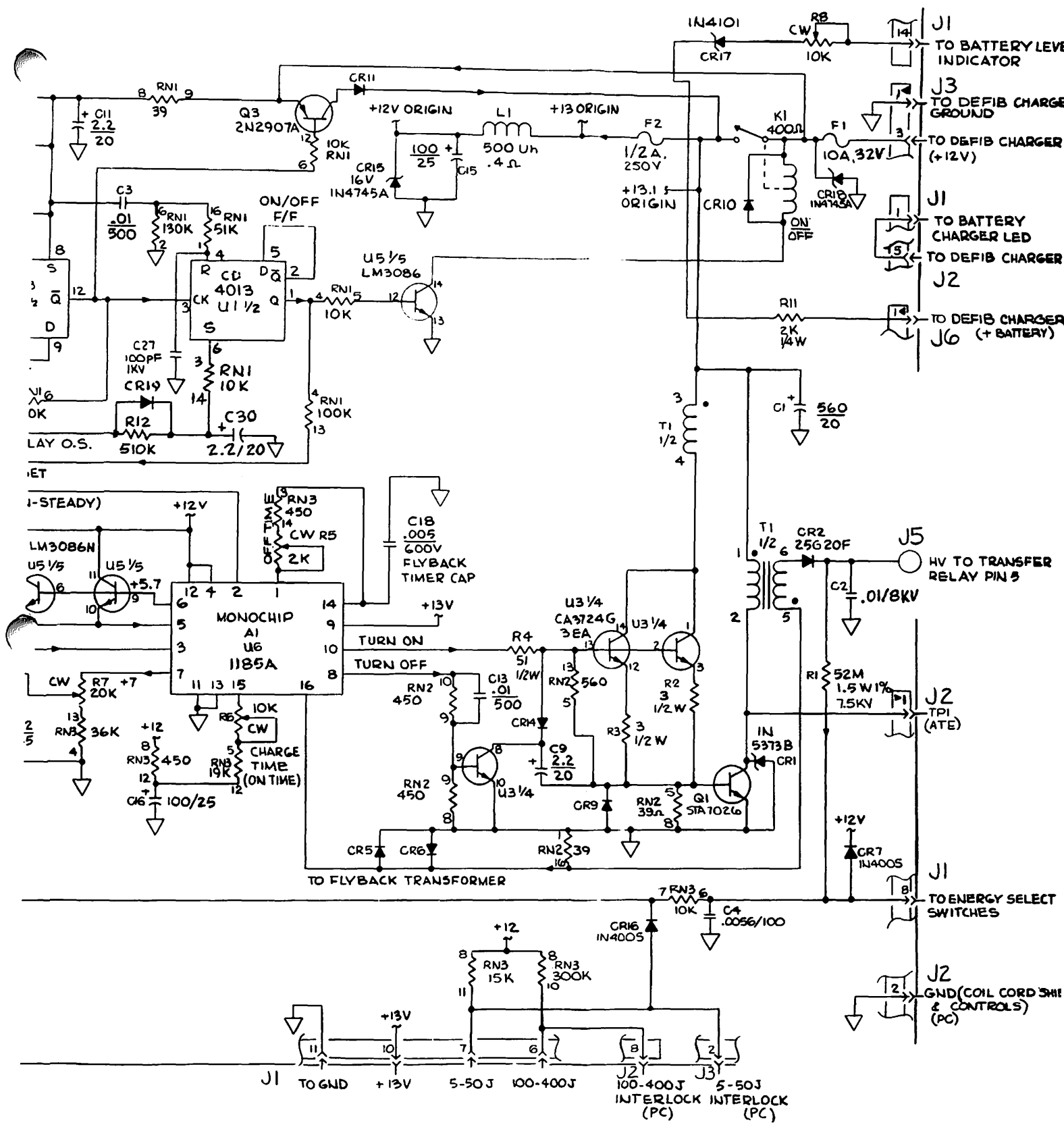

SPECIFIED  
 IN OHMS, 1/4W, 5%.  
 N MFD/WVDC.

800163

Figure 6-12 Main PCB Schematic

6-27/6-28

Jan 197

6-28

NOTES: UNLESS OTHERWISE SPECIFIED

1. ALL RESISTORS ARE IN OHMS, 1/4W, 5%.
2. ALL CAPACITORS IN MFD/WVDC.

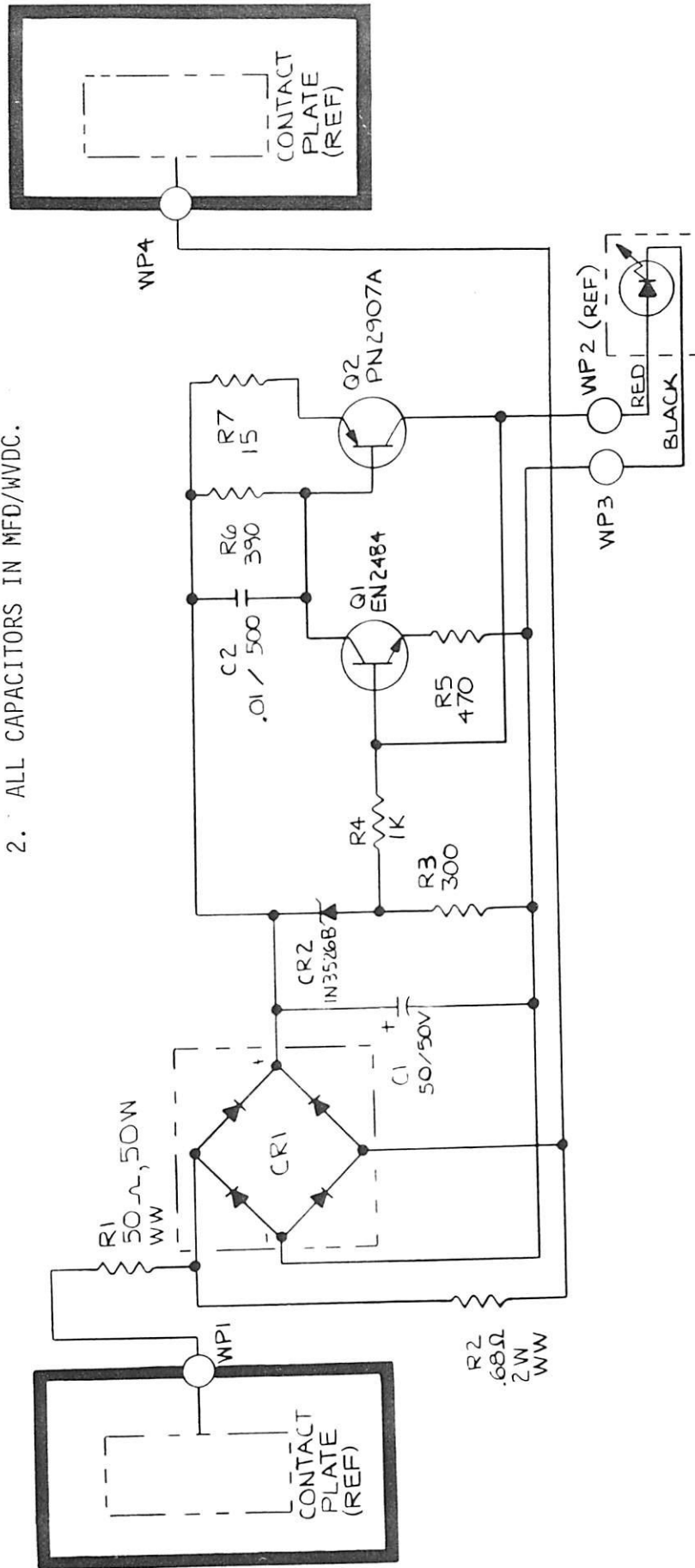
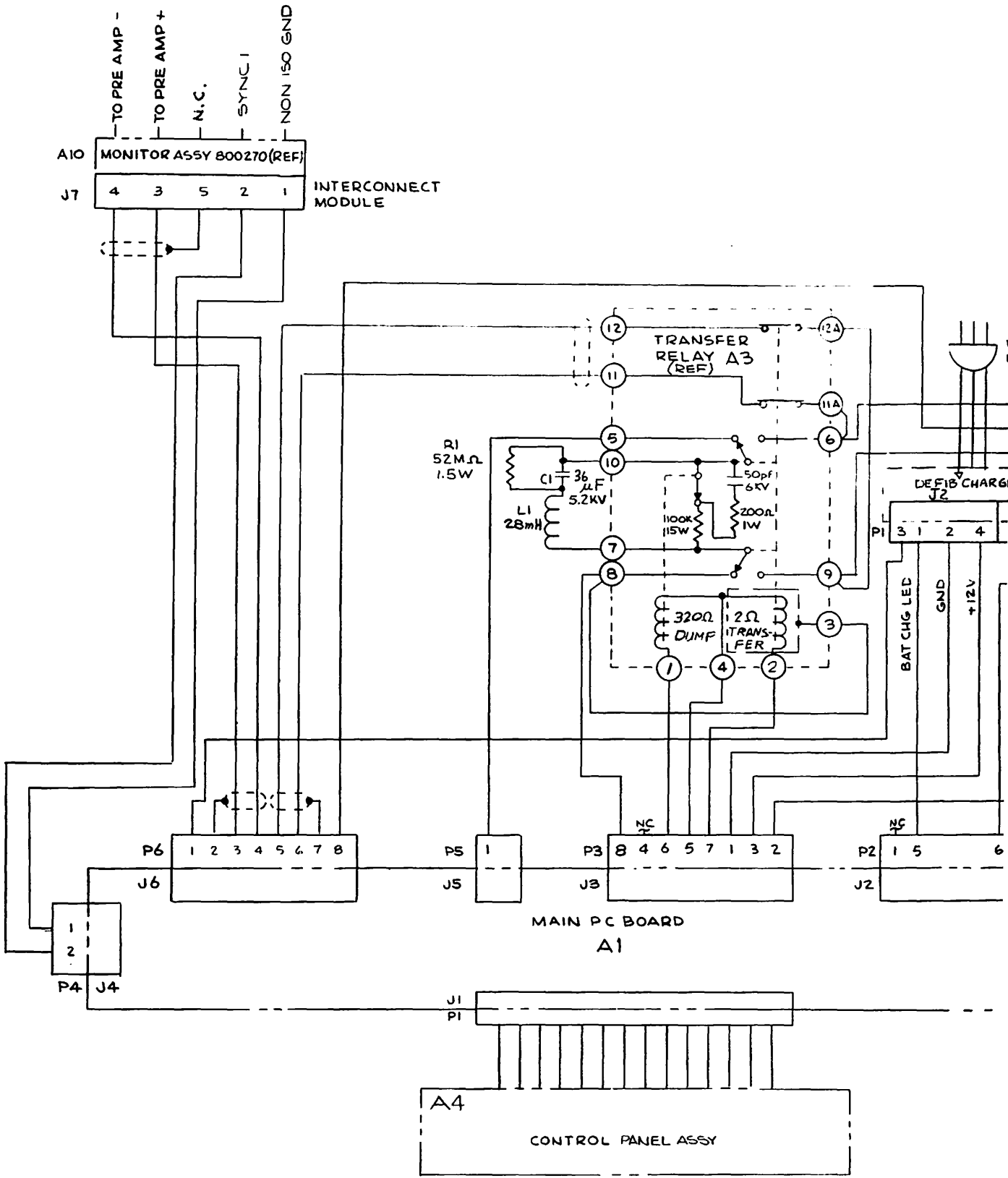

Figure 6-13 Test Load PCB Schematic

800167





6-30

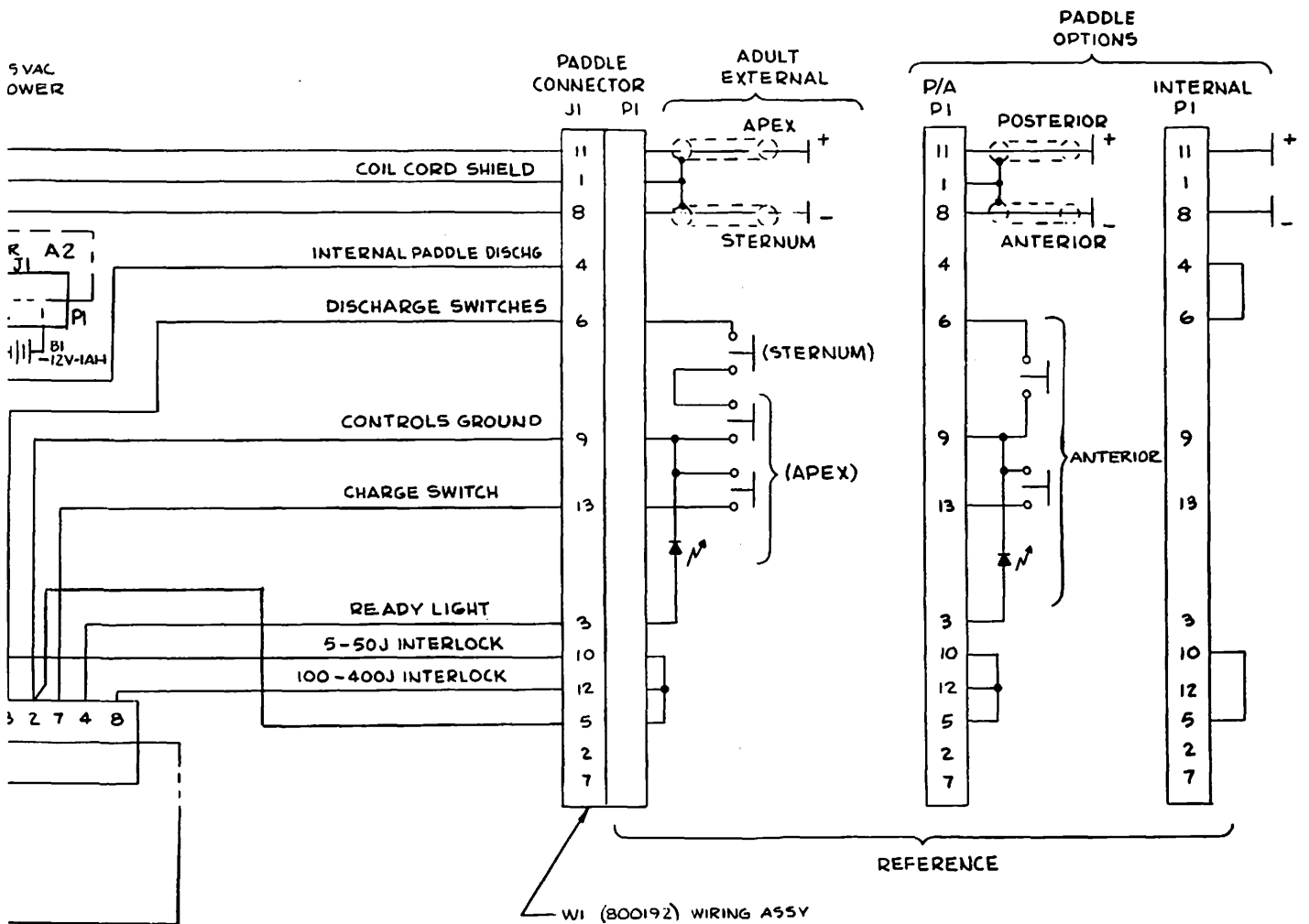

800260

6-31

Figure 6-14 Interconnect Diagram

6-3076-31

Jan. 1979

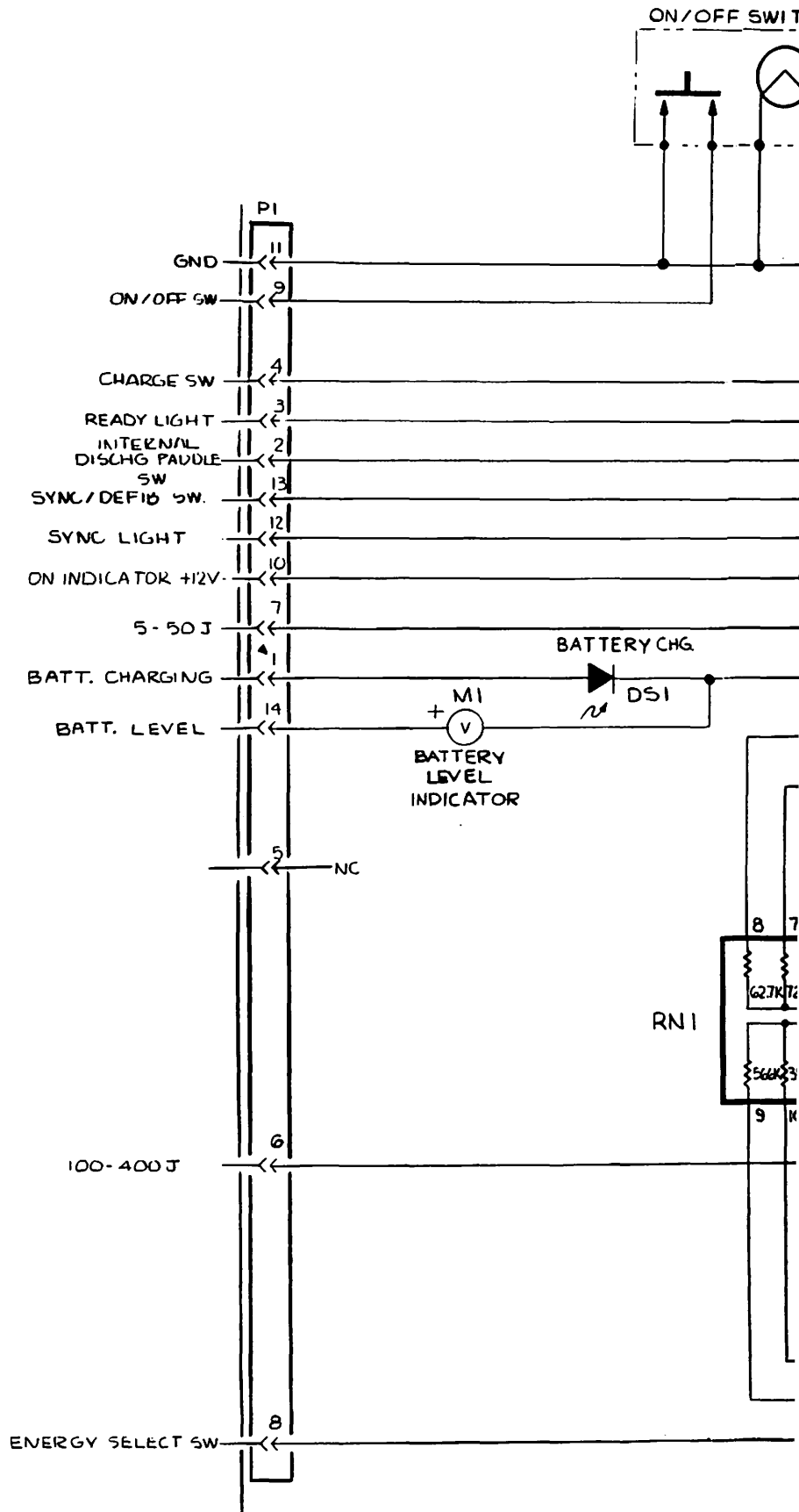

6-32

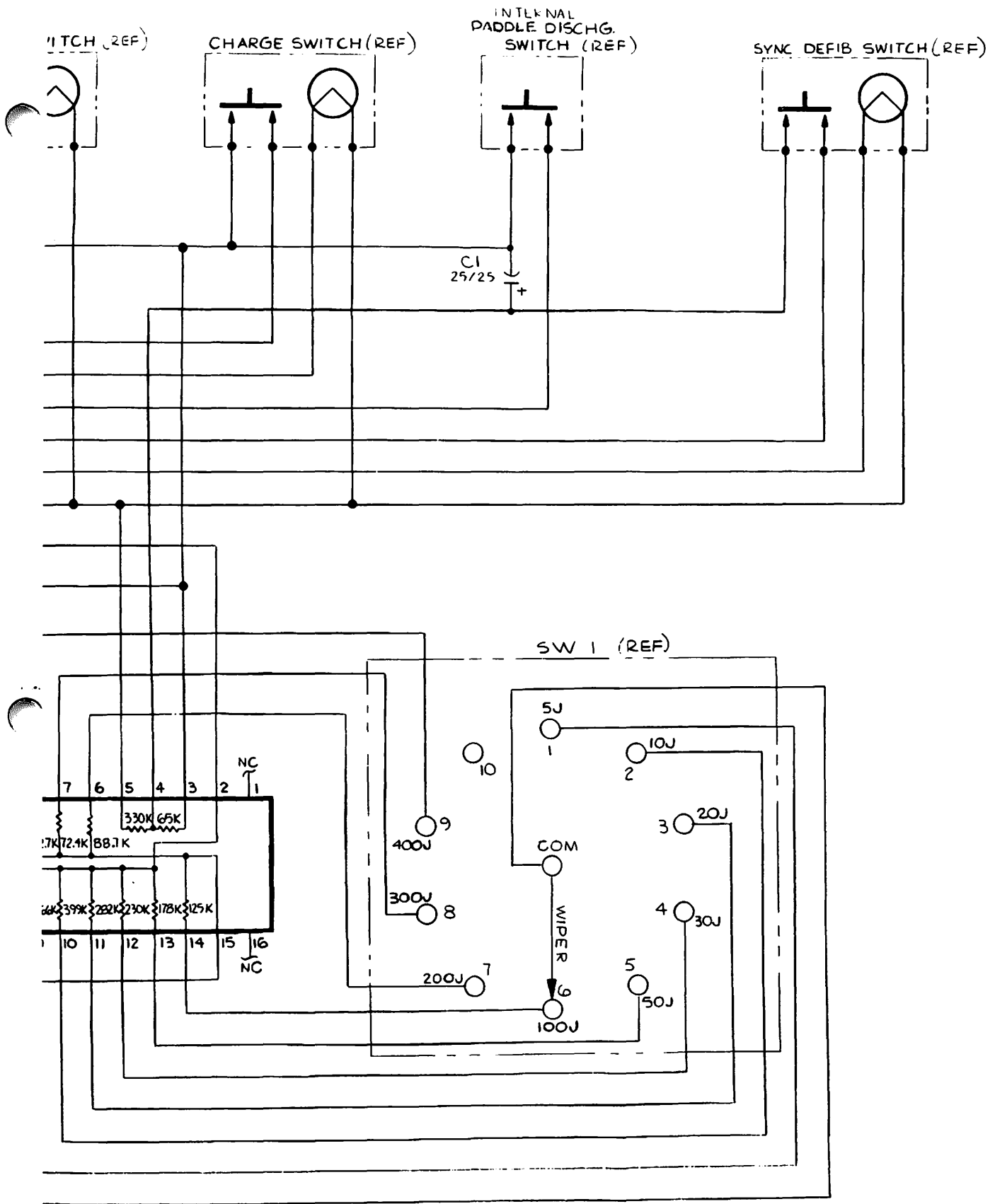

800165

Figure 6-15. Control Panel Flex Cable Schematic

6-32/6-33

Jan.

633

### **CHANGE INFORMATION**

**At Physio-Control, we continually strive to keep the product and documentation up with latest developments. Sometimes, due to printing and shipping requirements, we can't get this information immediately into printed manuals. Hence, your manual may contain new change information in this section. If no such information appears in this section, your manual is correct as printed.**

## **Physio-Control**

11811 Willows Road  
Redmond, Washington 98052 U.S.A.  
206/883-1181  
Cable: PHYSIO-RED, Telex: 32-0166